

PoleStar Smart-E Refrigeration Dryers

PSE 325 - 6000
60Hz - UL Listed



Compressed air systems inherently suffer from performance and reliability issues, most of which can be directly attributed to water in one form or another. In fact, water accounts for up to 99.9% of the total liquid contamination found in a compressed air system. Therefore, an air treatment is essential for manufacturing facilities reliant on compressed air for automation.

For general purpose or non-critical use of compressed air, refrigeration dryers are an ideal choice. Refrigeration dryers utilize a closed loop cooling system to lower the temperature of the compressed air to just above freezing, causing condensation of water vapor.

Most of the condensed liquid is then removed by an integral water separator and drained away. Prior to leaving the dryer, the compressed air is re-heated by the incoming compressed air to prevent condensation on the outside of the downstream distribution piping.

Refrigeration dryers should always be installed with general purpose and high efficiency coalescing filters and are an effective way to reduce water vapor, liquid water and water aerosols for general purpose compressed air applications.

Parker's PoleStar Smart-E (PSE) dryers are the most environmentally friendly refrigeration dryers available. Designed to work with low Global Warming Potential (GWP) refrigerant, R513A, PSE complies with the requirements of the United States Environmental Protection Agency SNAP Rules 20 & 21 and European F-Gas Regulation (EU 517/2014). This makes Parker PSE the best choice to protect your investment, the climate and the environment.



Advantages

- State-of-the art aluminum SmartPack heat exchanger includes a large air-to-air heat exchanger to pre-cool incoming compressed air and reduce energy consumption
- Efficient SmartPack HX, electronic hot-gas valve and innovative micro-channel condensers result in lower adsorbed power and about 40% less refrigerant versus additional solutions
- Low pressure drop design of the Smart-Pack HX and low absorbed power of the refrigerant circuit make PSE dryers a highly competitive solution with lower operating costs vs comparable dryers.
- Comprehensive electronic controllers, including touch screen panels on PSE700 and larger, provide indication of compressed air temperature, service reminder, data log, alarm history, integral capacitive drain control and much more.
- LED unit status indicator on model PSE1400 and larger.
- High and low pressure gauges for refrigerant circuit on models PSE700 and larger.
- Remote communication protocol, industry 4.0 ready, on all units; web server from model PSE700 and IoT ready from model PSE1400.
- Energy savings technology that enables all PSE dryers to save energy by cycling the refrigerant compressor off at partial load while maintaining a constant outlet dewpoint.
- Variable speed fans on PSE1400 and larger deliver additional cost savings at partial load and increased condensation stability.
- Compliant scroll refrigeration compressors offer longer life, lower noise and energy savings of up to 20% compared to piston alternatives.
- Inlet and outlet air connections installed on both sides of PSE2000 and larger allow for installation flexibility and simplify banking multiple units together.
- Low Global Warming Potential (GWP) refrigerant, R513A, used on all PSE units - protecting the environment.



ENGINEERING YOUR SUCCESS.

Dryer Performance

Model	ISO 8573-1 Dewpoint	Design Inlet Pressure**		Design Inlet Temperature		Design Ambient Temperature	
		psi g	bar g	°F	°C	°F	°C
PSE 325-6000	Class 5*	100	7	100	100	100	38

*ISO8573-1 Class 5 for Water means pressure dewpoint is equal to or less than 44.5°F (7°C) at design conditions.

**Inlet pressure is with reference to 68°F (20°C), 14.5 psi a (1 bar a), 0% relative water vapor pressure.

Technical Data

Dryer Models	Min Operating Pressure		Max Operating Pressure		Min Operating Temperature		Max Operating Temperature		Max Ambient Temperature		Electrical Supply (Standard)	Connection Type	Noise Level
	psi g	bar g	psi g	bar g	°F	°C	°F	°C	°F	°C			dB(A)
PSE 1325-1000	29	2	203	14	41	5	149	65	122	50	460V 3ph 60Hz	NPT FLG	<75
PSE 1400-6000													

Flow Rates

Model	Pipe Size	Inlet Flow Rate				Condenser Type	
		cfm	m3/min	m3/hr	L/s	Air Cooled	Water Cooled
PSE 325	2"	325	9.2	552	153	Standard	N/A
PSE 400	2"	400	11.3	680	189	Standard	N/A
PSE 500	2"	500	14.2	850	236	Standard	N/A
PSE 700	2 1/2"	700	19.8	1189	330	Standard	N/A
PSE 800	2 1/2"	800	22.7	1359	378	Standard	N/A
PSE 1000	2 1/2"	1000	28.3	1699	472	Standard	Optional
PSE 1400	4"	1400	39.6	2379	661	Standard	Optional
PSE 1600	4"	1600	45.3	2718	755	Standard	Optional
PSE 2000	6"	2000	56.6	3398	944	Standard	Optional
PSE 2400	6"	2400	68.0	4078	1133	Standard	Optional
PSE 3000	6"	3000	85.0	5097	1416	Standard	Optional
PSE 3800	6"	3800	107.6	6456	1793	Standard	Optional
PSE 5000	8"	5000	141.6	8495	2360	Standard	Optional
PSE 6000	8"	6000	169.9	10194	2832	Standard	Optional

Stated flows are for operation at 100 psi g (7 bar g) with reference to 68°F (20°C), 14.5 psi a (1 bar a), 0% relative water vapor pressure, 100°F (38°C) ambient air temperature and 100°F (38°C) air inlet temperature. **All models supplied with low GWP refrigerant R513A.**

For flows at other conditions, apply the correction factors shown below.

Product Selection & Correction Factors

For correct operation, compressed air dryers must be sized using for the maximum (summer) inlet temperature, maximum (summer) ambient temperature, minimum inlet pressure, and maximum flow rate of the installation.

To select a dryer, first calculate the MDC (Minimum Drying Capacity) using the formula below then select a dryer from the flow rate table above with a flow rate equal to or above the MDC.

$$\text{Minimum Drying Capacity} = \text{System Flow} \times \text{CFIT} \times \text{CFAT} \times \text{CFMIP}$$

CFIT - Correction Factor Maximum Inlet Temperature

Maximum Inlet Temperature	°F	80	85	90	95	100	110	120	130	140	149
	°C	26.7	29.4	32.2	35.0	37.8	43.3	48.9	54.4	60.0	65.0
Correction Factor	CFIT	0.64	0.68	0.77	0.87	1.00	1.28	1.62	2.24	2.50	2.81

CFAT - Correction Factor Maximum Ambient Temperature

Maximum Ambient Temperature	°F	60	70	80	90	100	110	120	122
	°C	15.6	21.1	26.7	32.2	37.8	43.3	48.9	50.0
Correction Factor	CFIT	0.96	0.96	0.96	0.97	1.00	1.08	1.24	1.28

CFMIP - Correction Factor Minimum Inlet Pressure

Minimum Inlet Pressure	psi g	45	60	70	80	90	100	115	130	145	160	175	190	203
	bar g	3.1	4.1	4.8	5.5	6.2	7.0	7.9	9.0	10.0	11.0	12.1	13.1	14.0
Correction Factor	CFMIP	1.44	1.24	1.16	1.09	1.03	1.00	0.96	0.93	0.91	0.88	0.87	0.85	0.85

Controller Features

PSE Model	Function									
	Touch Screen	Compr. Air Temp.	Fault indication	Service Indication	Energy Saving Tech.	Alarm History	Data Log/ Retrieve	Local Web Server	ModBus Protocol	IoT
325-500	N/A	✓	✓	✓	✓	✓	N/A	N/A	RTU RS485	N/A
700-1000	3.5"	✓	✓	✓	✓	✓	✓ Lan	✓	RTU RS485 TCP/IP RJ45	N/A
1400-6000	4.3"	✓	✓	✓	✓	✓	✓ Lan & USB	✓	RTU RS485 TCP/IP RJ45	✓

Recommended Filtration

Model	Pipe Size BSPB or NPT	Dryer Inlet	Dryer Outlet
		General Purpose Pre-Filter	High Efficiency Post Filter
PSE 325	2"	AOP040HNFI	AAP040HNFI
PSE 400	2"	AOP040HNFI	AAP040HNFI
PSE 500	2"	AOP045INFI	AAP045INFI
PSE 700	2 ½"	AOP045INFI	AAP045INFI
PSE 800	2 ½"	AOP050INFI	AAP050INFI
PSE 1000	2 ½"	AOP055INFI	AAP055INFI
PSE 1400	4"	Consult factory for fabricated flanged filter options.	
PSE 1600	4"		
PSE 2000	6"		
PSE 2400	6"		
PSE 3000	6"		
PSE 3800	6"		
PSE 5000	8"		
PSE 6000	8"		

Filtration Performance	General Purpose Pre-filter	High Efficiency Post Filter
Filtration Grade	Grade AO	Grade AA
Filtration Type	Coalescing	Coalescing
Particle Reduction (inc water & oil aerosols)	Down to 1 micron	Down to 0.01 micron
Maximum Remaining Oil Aerosol Content at 21°C	≤0.5 mg/m ³ (≤0.5 ppm(w))	≤0.01 mg/m ³ (≤0.01 ppm(w))
Filtration Efficiency	99.925%	99.9999%

Weights & Dimensions

Model	Pipe Size	Dimensions						Weight	
		Height (H)		Width (W)		Depth (D)			
		in	mm	in	mm	in	mm	lb	kg
PSE 325	2"	53.7	1365	27.7	703	45.3	1150	452	205
PSE 400	2"	53.7	1365	27.7	703	45.3	1150	452	205
PSE 500	2"	53.7	1365	27.7	703	45.3	1150	463	210
PSE 700	2 ½"	55.5	1410	27.7	703	45.3	1150	573	260
PSE 800	2 ½"	55.5	1410	27.7	703	45.3	1150	578	262
PSE 1000	2 ½"	55.5	1410	27.7	703	45.3	1150	582	264
PSE 1400	4"	80.9	2055	38.3	1287	50.7	1287	838	380
PSE 1600	4"	80.9	2055	38.3	1287	50.7	1287	926	420
PSE 2000	6"	80.9	2055	47.4	1974	77.7	1974	1609	730
PSE 2400	6"	80.9	2055	47.4	1974	77.7	1974	1698	770
PSE 3000	6"	80.9	2055	47.4	1974	77.7	1974	1874	850
PSE 3800	6"	80.9	2055	47.4	1974	77.7	1974	1874	850
PSE 5000	8"	80.3	2040	59.7	2529	99.6	2529	2359	1070
PSE 6000	8"	80.3	2040	59.7	2529	99.6	2529	2668	1210

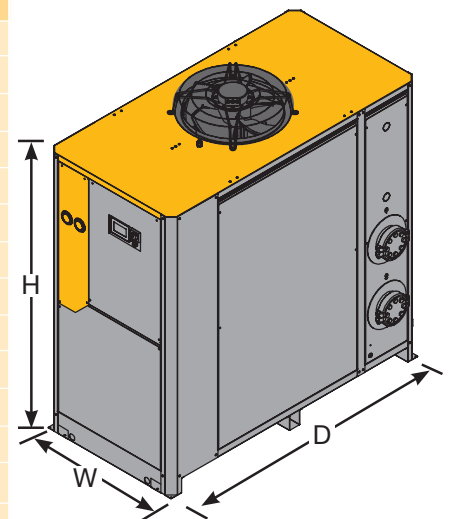

Quality Assurance / IP Rating / Pressure Vessel Approvals

Development / Manufacture	ISO 9001 / ISO 14001
Ingress Protection Rating	Indoor Use Only; IP44 from PSE 325-500, IP54 from PSE 700-6000
Electrical	UL508A
Pressure Vessel	Approved for fluid group 2 in accordance with the Pressure Equipment Directive 2014/68/EU
For use with Compressed Air Only	

Worldwide Filtration Manufacturing Locations

North America

Compressed Air Treatment

Industrial Gas Filtration and Generation Division

Lancaster, NY
716 686 6400
www.parker.com/igfg

Haverhill, MA
978 858 0505
www.parker.com/igfg

Engine Filtration

Racor

Modesto, CA
209 521 7860
www.parker.com/racor

Holly Springs, MS
662 252 2656
www.parker.com/racor

Hydraulic Filtration

Hydraulic & Fuel Filtration

Metamora, OH
419 644 4311
www.parker.com/hydraulicfilter

Laval, QC Canada
450 629 9594
www.parkerfarr.com

Velcon
Colorado Springs, CO
719 531 5855
www.velcon.com

Process Filtration

domnick hunter Process Filtration SciLog

Oxnard, CA
805 604 3400
www.parker.com/processfiltration

Water Purification

Village Marine, Sea Recovery, Horizon Reverse Osmosis

Carson, CA
310 637 3400
www.parker.com/watermakers

Europe

Compressed Air Treatment

domnick hunter Filtration & Separation

Gateshead, England
+44 (0) 191 402 9000
www.parker.com/dhfns

Parker Gas Separations

Etten-Leur, Netherlands
+31 76 508 5300
www.parker.com/dhfns

Hiross Zander

Essen, Germany
+49 2054 9340
www.parker.com/hzfd

Padova, Italy
+39 049 9712 111
www.parker.com/hzfd

Engine Filtration & Water Purification

Racor

Dewsbury, England
+44 (0) 1924 487 000
www.parker.com/rfde

Racor Research & Development

Stuttgart, Germany
+49 (0)711 7071 290-10

Hydraulic Filtration

Hydraulic Filter

Arnhem, Holland
+31 26 3760376
www.parker.com/hfde

Urkala, Finland
+358 20 753 2500

Condition Monitoring Parker Kittiwake

West Sussex, England
+44 (0) 1903 731 470
www.kittiwake.com

Process Filtration

domnick hunter Process Filtration Parker Twin Filter BV

Birtley, England
+44 (0) 191 410 5121
www.parker.com/processfiltration

Asia Pacific

Australia

Castle Hill, Australia
+61 2 9634 7777
www.parker.com/australia

China

Shanghai, China
+86 21 5031 2525
www.parker.com/china

India

Chennai, India
+91 22 4391 0700
www.parker.com/india

Parker Fowler

Bangalore, India
+91 80 2783 6794
www.johnfowlerindia.com

Japan

Tokyo, Japan
+81 45 870 1522
www.parker.com/japan

Korea

Hwaseon-City
+82 31 359 0852
www.parker.com/korea

Singapore

Jurong Town, Singapore
+65 6887 6300
www.parker.com/singapore

Thailand

Bangkok, Thailand
+66 2186 7000
www.parker.com/thailand

Latin America

Parker Comercio Ltda. Filtration Division

Sao Paulo, Brazil
+55 12 4009 3500
www.parker.com/br

Pan American Division

Miami, FL
305 470 8800
www.parker.com/panam

Africa

Aeroporto Kempton Park, South Africa
+27 11 9610700
www.parker.com/africa

