

Series TC15



AVENTICS™ Series TC15



Valve system, Series TC15

- Configurable valve systems



Blocking principle	Plate principle
Working pressure min./max.	-0.9 ... 10 bar
Ambient temperature min./max.	-10 ... 50 °C
Medium temperature min./max.	-10 ... 50 °C
Medium	Compressed air
Max. particle size	5 µm
Oil content of compressed air	0 ... 5 mg/m ³
Nominal flow Qn	1500 l/min
Number of valve positions max.	12
Protection class with connection	IP65

An example configuration is illustrated.
The delivered product may thus deviate from the illustration.

Overview of variants

	Version	You have the following options:
	Single plug-in wiring	Electrical connection Plug M8 plug, form C Valve plug connector

Technical information

The min. control pressure must be adhered to, since otherwise faulty switching and valve failure may result!
The pressure dew point must be at least 15 °C under ambient and medium temperature and may not exceed 3 °C .
The oil content of compressed air must remain constant during the life cycle.
Use only the approved oils from AVENTICS. Further information can be found in the "Technical information" document (available in the MediaCentre).

See the following pages on the series for technical data on individual components.
It is necessary to maintain the electrical current in the coil of double solenoid valves to avoid unexpected auto-switching.

Technical information

Material	
End plate	Die-cast aluminum
Seal	Acrylonitrile butadiene rubber
Base plate	Polyamide

8	227.5	215.5
10	269.5	257.5
12	311.5	299.5

n = number of valve positions

Dimensions

Dimensions in mm, pneumatic subbase, left, Thread connections acc. to ISO 228-1

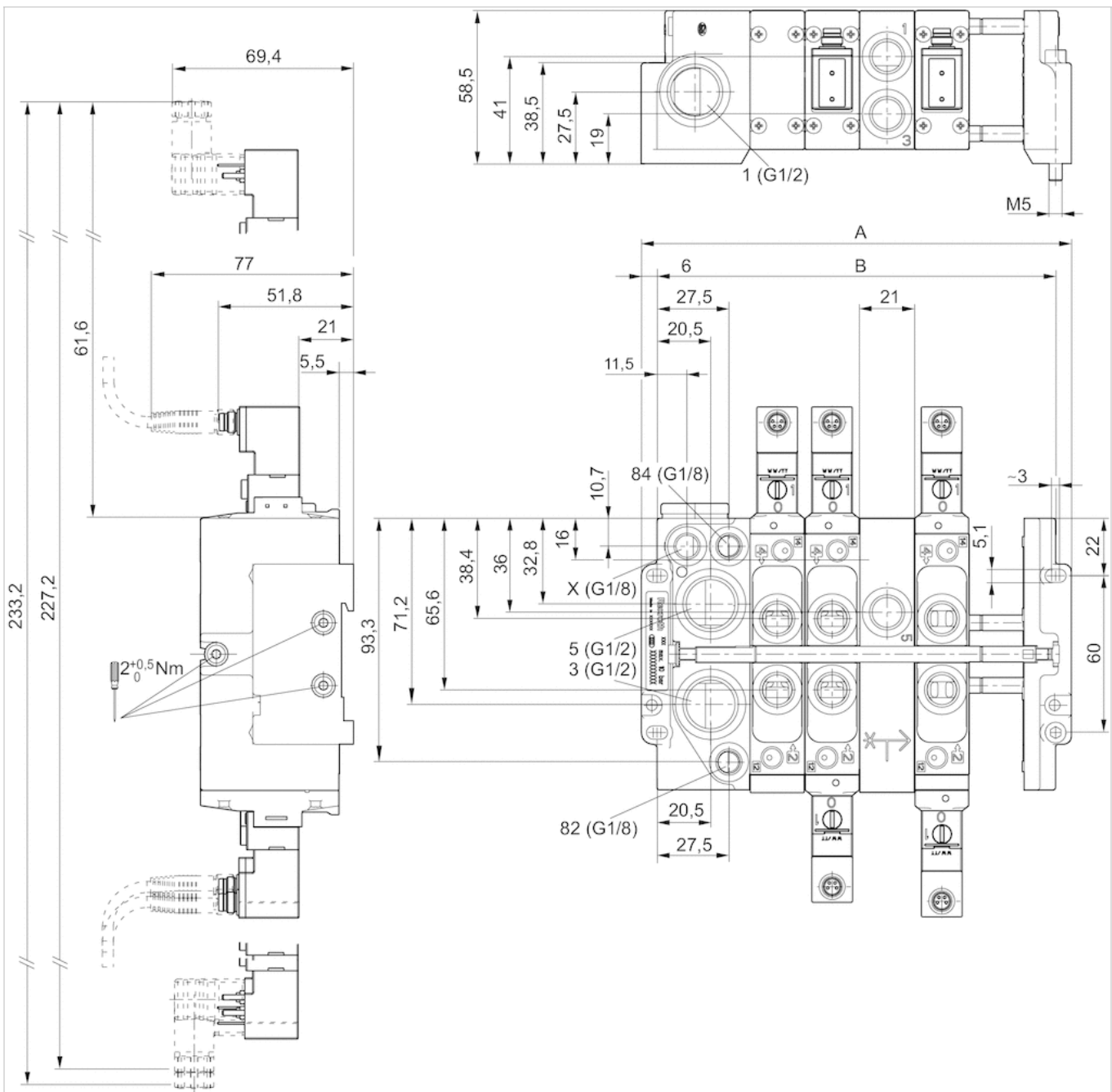

An example configuration is illustrated. The delivered product may thus deviate from the illustration.

Mounted via 4 through-holes in the end plates or assembly on DIN rail as per EN 60715

Dimensions

n	A	B
2	101.5	89.5
3	122.5	110.5
4	143.5	131.5
5	164.5	152.5
6	185.5	173.5
7	206.5	194.5
8	227.5	215.5
9	248.5	236.5
10	269.5	257.5
11	290.5	278.5
12	311.5	299.5

n = number of valve positions

n	A	B
10	293	281
11	314	302
12	335	323

n = number of valve positions







5/2-directional valve, Series TC15

- 5/3
- $Q_n = 1500 \text{ l/min}$
- Pilot valve width : 15 mm
- Plate connection Pipe connection
- Compressed air connection output : G 1/4
- Electrical connection : Plug, M8, 3-pin
- Can be assembled into blocks
- Manual override : with detent
- single solenoid double solenoid
- Pilot : External



Version	Spool valve, positive overlapping
Activation	Electrically
Pilot	External
Sealing principle	Soft sealing
Blocking principle	Plate principle
Working pressure min./max.	-0.9 ... 10 bar
Control pressure min./max.	See table below
Ambient temperature min./max.	-10 ... 50 °C
Medium temperature min./max.	-10 ... 50 °C
Medium	Compressed air
Max. particle size	5 μm
Oil content of compressed air	0 ... 5 mg/m^3
Nominal flow Q_n	1500 l/min
Connector standard	DIN EN 60947-5-2
Protection class acc. to DIN EN 61140	Class III
Electrically	
Protection class with connection	IP65
LED status display	Yellow
Duty cycle	100 %
Rail mounting DIN EN 60715	TH35 x 15
Weight	See table below

Technical data

Part No.		MO	Compressed air connection	Operational voltage
			Output	DC
R422100980			G 1/4	24 V
R422100981			G 1/4	24 V
R422100982			G 1/4	24 V

Part No.	Voltage tolerance	Power consumption	Flow conductance	Flow conductance
	DC	DC	b	C-value
R422100980	-10% / +10%	2.2 W	0.33	6.8 l/(s*bar)
R422100981	-10% / +10%	2.2 W	0.33	6.8 l/(s*bar)
R422100982	-10% / +10%	2.2 W	0.33	6.8 l/(s*bar)

R422100980	280 Ω	2.5 ... 10 bar	22 ms	20 ms	0.202 kg
R422100982	280 Ω	2 ... 10 bar	11 ms	11 ms	0.23 kg

Nominal flow Q_n at 6 bar and $\Delta p = 1$ bar, MO = Manual override

Technical information

The min. control pressure must be adhered to, since otherwise faulty switching and valve failure may result!

The pressure dew point must be at least 15 °C under ambient and medium temperature and may not exceed 3 °C .

The oil content of compressed air must remain constant during the life cycle.

Use only the approved oils from AVENTICS. Further information can be found in the "Technical information" document (available in the MediaCentre).

Technical information

Housing	Polyamide fiber-glass reinforced
Front plate	Polyamide fiber-glass reinforced

Pin assignments

PIN assignment and cable colors for valve plug connectors

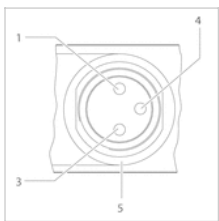

PIN assignment:

- 1) PIN not assigned
- 3) 0 V
- 4) 24 V
- 5) LED

Cable color

- 1) Brown
- 3) Blue
- 4) Black

Note: Bi-polar protective circuit to prevent overvoltage













5/2-directional valve, Series TC15

- 5/2-directional valve with air spring return 5/2-directional valve with spring return 5/2-directional valve, double solenoid
- Qn = 1500 l/min
- Pilot valve width : 15 mm
- Plate connection Pipe connection
- Compressed air connection output : G 1/4
- Electrical connection : Plug, M8, 4-pin
- Can be assembled into blocks
- Manual override : with detent without detent
- double solenoid single solenoid
- Pilot : External



Version	Spool valve, positive overlapping
Activation	Electrically
Pilot	External
Sealing principle	Soft sealing
Blocking principle	Plate principle
Working pressure min./max.	-0.9 ... 10 bar
Control pressure min./max.	See table below
Ambient temperature min./max.	-10 ... 50 °C
Medium temperature min./max.	-10 ... 50 °C
Medium	Compressed air
Nominal flow Qn	1500 l/min
Connector standard	DIN EN 60947-5-2
Protection class acc. to DIN EN 61140 Electrically	Class III
Protection class with connection	IP65
LED status display	Yellow
Duty cycle	100 %
Rail mounting DIN EN 60715	TH35 x 15
Weight	See table below

Technical data

Part No.		MO	Compressed air connection	
			Output	Operational voltage
0820058796			G 1/4	24 V
0820058797			G 1/4	24 V
0820058798			G 1/4	24 V
0820058896			G 1/4	24 V
0820058897			G 1/4	24 V
0820058898			G 1/4	24 V

Part No.	Voltage tolerance	Power consumption	Flow conductance	Flow conductance
	DC	DC	b	C-value
0820058796	-10% / +10%	2.2 W	0.33	6.8 l/(s*bar)
0820058797	-10% / +10%	2.2 W	0.33	6.8 l/(s*bar)
0820058798	-10% / +10%	2.2 W	0.33	6.8 l/(s*bar)

0820058897	-10% / +10%	2.2 W	0.33	6.8 l/(s*bar)
------------	-------------	-------	------	---------------

0820058796	280 Ω	2.5 ... 10 bar	22 ms	20 ms	0.202 kg
0820058798	280 Ω	2 ... 10 bar	11 ms	11 ms	0.23 kg
0820058897	280 Ω	3 ... 10 bar	12 ms	35 ms	0.202 kg

Nominal flow Qn at 6 bar and Δp = 1 bar, MO = Manual override

Technical information

The min. control pressure must be adhered to, since otherwise faulty switching and valve failure may result!
 The pressure dew point must be at least 15 °C under ambient and medium temperature and may not exceed 3 °C .
 The oil content of compressed air must remain constant during the life cycle.
 Use only the approved oils from AVENTICS. Further information can be found in the “Technical information” document (available in the MediaCentre).

Technical information

Housing	Polyamide fiber-glass reinforced
Front plate	Polyamide fiber-glass reinforced

Pin assignments

PIN assignment and cable colors for valve plug connectors

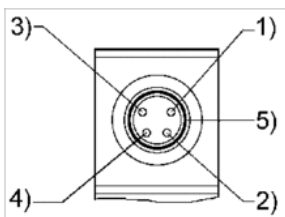

- PIN assignment:
- 1) PIN not assigned
 - 2) PIN not assigned
 - 3) 0 V
 - 4) 24 V
 - 5) LED

Cable colors

- 1) Brown
- 2) White
- 3) Blue
- 4) Black







5/3-directional valve, Series TC15

- 5/3
- Qn = 1300 l/min
- Pilot valve width : 15 mm
- closed center exhausted center pressurized center
- Plate connection Pipe connection
- Compressed air connection output : G 1/4
- Electrical connection : Plug, M8, 3-pin
- Can be assembled into blocks
- Manual override : with detent
- double solenoid
- Pilot : External

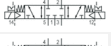

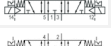
Version	Spool valve, positive overlapping
Activation	Electrically
Pilot	External
Sealing principle	Soft sealing
Blocking principle	Plate principle
Working pressure min./max.	-0.9 ... 10 bar
Control pressure min./max.	3 ... 10 bar
Ambient temperature min./max.	-10 ... 50 °C
Medium temperature min./max.	-10 ... 50 °C
Medium	Compressed air
Nominal flow Qn	1300 l/min
Connector standard	DIN EN 60947-5-2
Protection class acc. to DIN EN 61140	Class III
Electrically	
Protection class with connection	IP65
LED status display	Yellow
Duty cycle	100 %
Typ. switch-on time	12 ms
Typ. switch-off time	13 ms
Rail mounting DIN EN 60715	TH35 x 15
Weight	0.245 kg

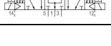
Technical data

Part No.		MO		Compressed air connection	
					Output
R422100983			closed center		G 1/4
R422100984			exhausted center		G 1/4
R422100985			pressurized center		G 1/4

Part No.	Operational voltage	Voltage tolerance		Power consumption	
		DC	DC	DC	DC
R422100983	24 V	-10% / +10%		2.2 W	
R422100984	24 V	-10% / +10%		2.2 W	
R422100985	24 V	-10% / +10%		2.2 W	

R422100983	0.31	5.9 l/(s*bar)	280 Ω
R422100985	0.31	5.9 l/(s*bar)	280 Ω

Nominal flow Qn at 6 bar and Δp = 1 bar, MO = Manual override

Technical information

The min. control pressure must be adhered to, since otherwise faulty switching and valve failure may result!
 The pressure dew point must be at least 15 °C under ambient and medium temperature and may not exceed 3 °C .
 The oil content of compressed air must remain constant during the life cycle.
 Use only the approved oils from AVENTICS. Further information can be found in the "Technical information" document (available in the MediaCentre).

Technical information

Housing	Polyamide fiber-glass reinforced
Front plate	Polyamide fiber-glass reinforced

Pin assignments

PIN assignment and cable colors for valve plug connectors

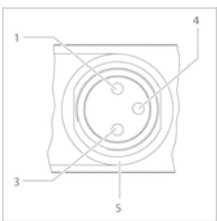

PIN assignment:

- 1) PIN not assigned
- 3) 0 V
- 4) 24 V
- 5) LED

Cable color

- 1) Brown
- 3) Blue
- 4) Black

Note: Bi-polar protective circuit to prevent overvoltage

5/3-directional valve, Series TC15

- 5/3-directional valve, closed center 5/3-directional valve, exhausted center 5/3-directional valve, pressurized center
- Qn = 1300 l/min
- Pilot valve width : 15 mm
- closed center exhausted center pressurized center
- Plate connection Pipe connection
- Compressed air connection output : G 1/4
- Electrical connection : Plug, M8, 4-pin
- Can be assembled into blocks
- Manual override : with detent without detent
- double solenoid
- Pilot : External



Version	Spool valve, positive overlapping
Activation	Electrically
Pilot	External
Sealing principle	Soft sealing
Blocking principle	Plate principle
Working pressure min./max.	-0.9 ... 10 bar
Control pressure min./max.	3 ... 10 bar
Ambient temperature min./max.	-10 ... 50 °C
Medium temperature min./max.	-10 ... 50 °C
Medium	Compressed air
Nominal flow Qn	1300 l/min
Connector standard	DIN EN 60947-5-2
Protection class acc. to DIN EN 61140	Class III
Electrically	
Protection class with connection	IP65
LED status display	Yellow
Duty cycle	100 %
Typ. switch-on time	12 ms
Typ. switch-off time	13 ms
Rail mounting DIN EN 60715	TH35 x 15
Weight	0.245 kg

Technical data

Part No.	MO	Compressed air connection	Compressed air connection	
			Output	
0820059796		closed center	G 1/4	
0820059797		exhausted center	G 1/4	
0820059798		pressurized center	G 1/4	
0820059896		closed center	G 1/4	
0820059897		exhausted center	G 1/4	
0820059898		pressurized center	G 1/4	

Part No.	Operational voltage	Voltage tolerance	Power consumption
		DC	DC

0820059796	24 V	-10% / +10%	2.2 W
0820059798	24 V	-10% / +10%	2.2 W
0820059897	24 V	-10% / +10%	2.2 W

0820059796	0.31	5.9 l/(s*bar)	280 Ω
0820059798	0.31	5.9 l/(s*bar)	280 Ω
0820059897	0.31	5.9 l/(s*bar)	280 Ω

Nominal flow Qn at 6 bar and Δp = 1 bar, MO = Manual override

Technical information

The min. control pressure must be adhered to, since otherwise faulty switching and valve failure may result!
 The pressure dew point must be at least 15 °C under ambient and medium temperature and may not exceed 3 °C .
 The oil content of compressed air must remain constant during the life cycle.
 Use only the approved oils from AVENTICS. Further information can be found in the “Technical information” document (available in the MediaCentre).

Technical information

Housing	Polyamide fiber-glass reinforced
Front plate	Polyamide fiber-glass reinforced

Pin assignments

PIN assignment and cable colors for valve plug connectors

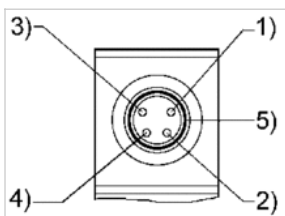

PIN assignment:
 1) PIN not assigned

2) PIN not assigned

3) 0 V

4) 24 V

5) LED

Cable colors

1) Brown

2) White

3) Blue

4) Black













2x3/2-directional valve, Series TC15

- Qn = 1100 l/min
- Pilot valve width : 15 mm
- NC/NC NO/NO NC/NO
- Plate connection Pipe connection
- Compressed air connection output : G 1/4
- Electrical connection : Plug, ISO 15217, form C
- Can be assembled into blocks
- Manual override : with detent without detent
- double solenoid
- With spring return
- Pilot : External



Version	Spool valve, positive overlapping
Activation	Electrically
Pilot	External
Sealing principle	Soft sealing
Blocking principle	Plate principle
Working pressure min./max.	-0.9 ... 10 bar
Control pressure min./max.	3 ... 10 bar
Ambient temperature min./max.	-10 ... 50 °C
Medium temperature min./max.	-10 ... 50 °C
Medium	Compressed air
Max. particle size	5 µm
Oil content of compressed air	0 ... 5 mg/m ³
Nominal flow Qn	1100 l/min
Connector standard	ISO 15217
Protection class with connection	IP65
Duty cycle	100 %
Typ. switch-on time	12 ms
Typ. switch-off time	16 ms
Generic emission standard in accordance with	EN 50081-2:1993
Generic immunity standard in accordance with	EN 50082-2
Weight	0.25 kg

Technical data

Part No.		MO		Compressed air connection	Operational voltage
				Output	DC
R422102197			NC/NC	G 1/4	24 V
R422102201			NO/NO	G 1/4	24 V
R422102205			NC/NO	G 1/4	24 V
R422102209			NC/NC	G 1/4	24 V
R422102213			NO/NO	G 1/4	24 V
R422102217			NC/NO	G 1/4	24 V

Part No.	Voltage tolerance	Power consumption	Flow conductance	Flow conductance
	DC	DC	b	C-value
R422102197	-10% / +10%	2 W	0.25	5.9 l/(s*bar)
R422102201	-10% / +10%	2 W	0.25	5.9 l/(s*bar)
R422102205	-10% / +10%	2 W	0.25	5.9 l/(s*bar)
R422102209	-10% / +10%	2 W	0.25	5.9 l/(s*bar)
R422102213	-10% / +10%	2 W	0.25	5.9 l/(s*bar)
R422102217	-10% / +10%	2 W	0.25	5.9 l/(s*bar)

Part No.	Nominal resistance
R422102197	280 Ω
R422102201	280 Ω
R422102205	280 Ω
R422102209	280 Ω
R422102213	280 Ω
R422102217	280 Ω

Nominal flow Q_n at 6 bar and $\Delta p = 1$ bar, MO = Manual override

Technical information

The min. control pressure must be adhered to, since otherwise faulty switching and valve failure may result!

The pressure dew point must be at least 15 °C under ambient and medium temperature and may not exceed 3 °C .

The oil content of compressed air must remain constant during the life cycle.

Use only the approved oils from AVENTICS. Further information can be found in the "Technical information" document (available in the MediaCentre).

Technical information

Material	
Housing	Polyamide fiber-glass reinforced
Seals	Acrylonitrile butadiene rubber Hydrogenated nitrile butadiene rubber
Front plate	Polyamide fiber-glass reinforced
Threaded bushing	Brass Die cast zinc, nickel-plated chrome-plated















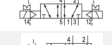

5/2-directional valve, Series TC15

- 5/2
- $Q_n = 1500 \text{ l/min}$
- Pilot valve width : 15 mm
- Plate connection Pipe connection
- Compressed air connection output : G 1/4
- Electrical connection : Plug, ISO 15217, form C
- Can be assembled into blocks
- Manual override : with detent without detent
- single solenoid double solenoid
- Pilot : External

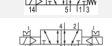

Version	Spool valve, positive overlapping
Activation	Electrically
Pilot	External
Sealing principle	Soft sealing
Blocking principle	Plate principle
Working pressure min./max.	-0.9 ... 10 bar
Control pressure min./max.	See table below
Ambient temperature min./max.	-10 ... 50 °C
Medium temperature min./max.	-10 ... 50 °C
Medium	Compressed air
Max. particle size	5 μm
Nominal flow Q_n	1500 l/min
Connector standard	ISO 15217
Protection class with connection	IP65
Duty cycle	100 %
Rail mounting DIN EN 60715	TH35 x 15
Weight	See table below

Technical data

Part No.	MO	Compressed air connection		Operational voltage
		Input	Output	
0820058751			G 1/4	24 V
0820058761			G 1/4	24 V
0820058771			G 1/4	24 V
R422103060			G 1/4	-
0820058851			G 1/4	24 V
0820058861			G 1/4	24 V
R422103061			G 1/4	-
0820058871			G 1/4	24 V

Part No.	Voltage tolerance	Power consumption	Flow conductance	Flow conductance
	DC	DC	b	C-value
0820058751	-10% / +10%	2 W	0.33	6.8 l/(s*bar)
0820058761	-10% / +10%	2 W	0.33	6.8 l/(s*bar)
0820058771	-10% / +10%	2 W	0.33	6.8 l/(s*bar)
R422103060	-	-	0.33	6.8 l/(s*bar)

Part No.	Voltage tolerance	Power consumption	Flow conductance	Flow conductance
	DC	DC	b	C-value
0820058851	-10% / +10%	2 W	0.33	6.8 l/(s*bar)
0820058861	-10% / +10%	2 W	0.33	6.8 l/(s*bar)
R422103061	-	-	0.33	6.8 l/(s*bar)
0820058871	-10% / +10%	2 W	0.33	6.8 l/(s*bar)

Part No.	Nominal resistance	Control pressure min./max.	Typ. switch-on time	Typ. switch-off time
0820058751	280 Ω	2.5 ... 10 bar	22 ms	20 ms
0820058761	280 Ω	3 ... 10 bar	12 ms	35 ms
0820058771	280 Ω	2 ... 10 bar	11 ms	11 ms
R422103060	-	3 ... 10 bar	12 ms	35 ms
0820058851	280 Ω	2.5 ... 10 bar	22 ms	20 ms
0820058861	280 Ω	3 ... 10 bar	12 ms	35 ms
R422103061	-	2 ... 10 bar	11 ms	11 ms
0820058871	280 Ω	2 ... 10 bar	11 ms	11 ms

Part No.	basic valve with electrical connector	Weight
0820058751	-	0.201 kg
0820058761	-	0.201 kg
0820058771	-	0.229 kg
R422103060	Basic valve without coil	0.201 kg
0820058851	-	0.201 kg
0820058861	-	0.201 kg
R422103061	Basic valve without coil	0.229 kg
0820058871	-	0.229 kg

Nominal flow Q_n at 6 bar and $\Delta p = 1$ bar, MO = Manual override

Technical information

The min. control pressure must be adhered to, since otherwise faulty switching and valve failure may result!

The pressure dew point must be at least 15 °C under ambient and medium temperature and may not exceed 3 °C .

The oil content of compressed air must remain constant during the life cycle.

Use only the approved oils from AVENTICS. Further information can be found in the "Technical information" document (available in the MediaCentre).

Technical information

Material	
Housing	Polyamide fiber-glass reinforced
Seals	Acrylonitrile butadiene rubber Hydrogenated nitrile butadiene rubber
Front plate	Polyamide fiber-glass reinforced
Threaded bushing	Brass Die cast zinc, nickel-plated chrome-plated

Dimensions

Dimensions

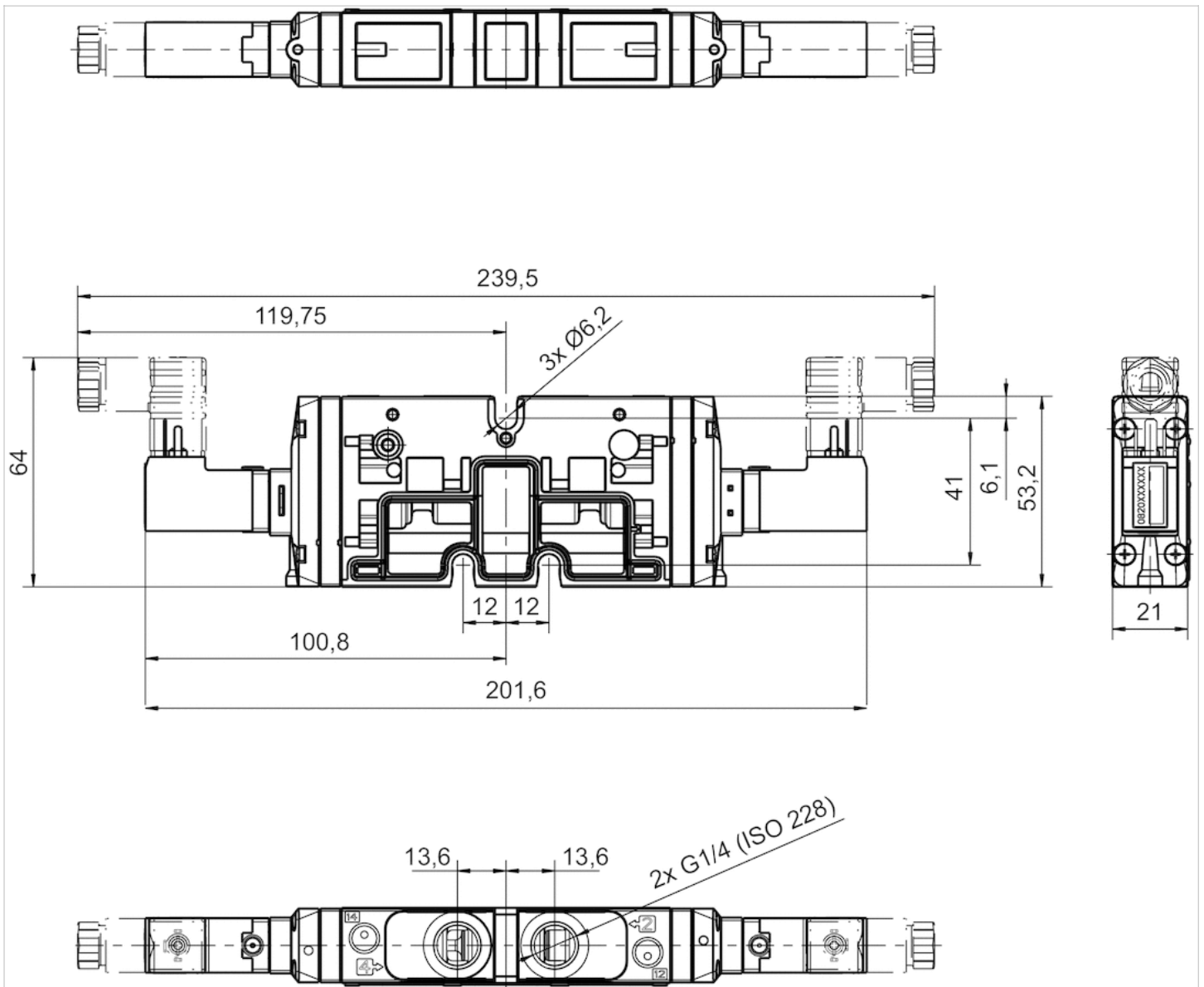

5/3-directional valve, Series TC15

- 5/3
- Qn = 1300 l/min
- Pilot valve width : 15 mm
- closed center exhausted center pressurized center
- Plate connection Pipe connection
- Compressed air connection output : G 1/4
- Electrical connection : Plug, ISO 15217, form C
- Can be assembled into blocks
- Manual override : with detent without detent
- double solenoid
- Pilot : External



Version	Spool valve, positive overlapping
Activation	Electrically
Pilot	External
Sealing principle	Soft sealing
Blocking principle	Plate principle
Working pressure min./max.	-0.9 ... 10 bar
Control pressure min./max.	3 ... 10 bar
Ambient temperature min./max.	-10 ... 50 °C
Medium temperature min./max.	-10 ... 50 °C
Medium	Compressed air
Max. particle size	5 µm
Nominal flow Qn	1300 l/min
Connector standard	ISO 15217
Protection class with connection	IP65
Duty cycle	100 %
Typ. switch-on time	12 ms
Typ. switch-off time	13 ms
Rail mounting DIN EN 60715	TH35 x 15
Weight	0.244 kg

Technical data

Part No.	MO	MO	Compressed air connection
0820059751		closed center	G 1/4
0820059761		exhausted center	G 1/4
0820059771		pressurized center	G 1/4
0820059851		closed center	G 1/4
R422103062		closed center	G 1/4
0820059861		exhausted center	G 1/4
0820059871		pressurized center	G 1/4

Part No.	Operational voltage	Voltage tolerance	Power consumption
0820059751	24 V	-10% / +10%	2 W
0820059761	24 V	-10% / +10%	2 W

Part No.	Operational voltage	Voltage tolerance	Power consumption
		DC	DC
0820059771	24 V	-10% / +10%	2 W
0820059851	24 V	-10% / +10%	2 W
R422103062	-	-	-
0820059861	24 V	-10% / +10%	2 W
0820059871	24 V	-10% / +10%	2 W

Part No.	Flow conductance	Flow conductance	Nominal resistance	basic valve with electrical connector
	b	C-value		
0820059751	0.31	5.9 l/(s*bar)	280 Ω	-
0820059761	0.31	5.9 l/(s*bar)	280 Ω	-
0820059771	0.31	5.9 l/(s*bar)	280 Ω	-
0820059851	0.31	5.9 l/(s*bar)	280 Ω	-
R422103062	0.31	5.9 l/(s*bar)	-	Basic valve without coil
0820059861	0.31	5.9 l/(s*bar)	280 Ω	-
0820059871	0.31	5.9 l/(s*bar)	280 Ω	-

Nominal flow Qn at 6 bar and $\Delta p = 1$ bar, MO = Manual override

Technical information

The min. control pressure must be adhered to, since otherwise faulty switching and valve failure may result!

The pressure dew point must be at least 15 °C under ambient and medium temperature and may not exceed 3 °C .

The oil content of compressed air must remain constant during the life cycle.

Use only the approved oils from AVENTICS. Further information can be found in the "Technical information" document (available in the MediaCentre).

Technical information

Material	
Housing	Polyamide fiber-glass reinforced
Seals	Acrylonitrile butadiene rubber Hydrogenated nitrile butadiene rubber
Front plate	Polyamide fiber-glass reinforced
Threaded bushing	Brass Die cast zinc, nickel-plated chrome-plated

Dimensions

Dimensions

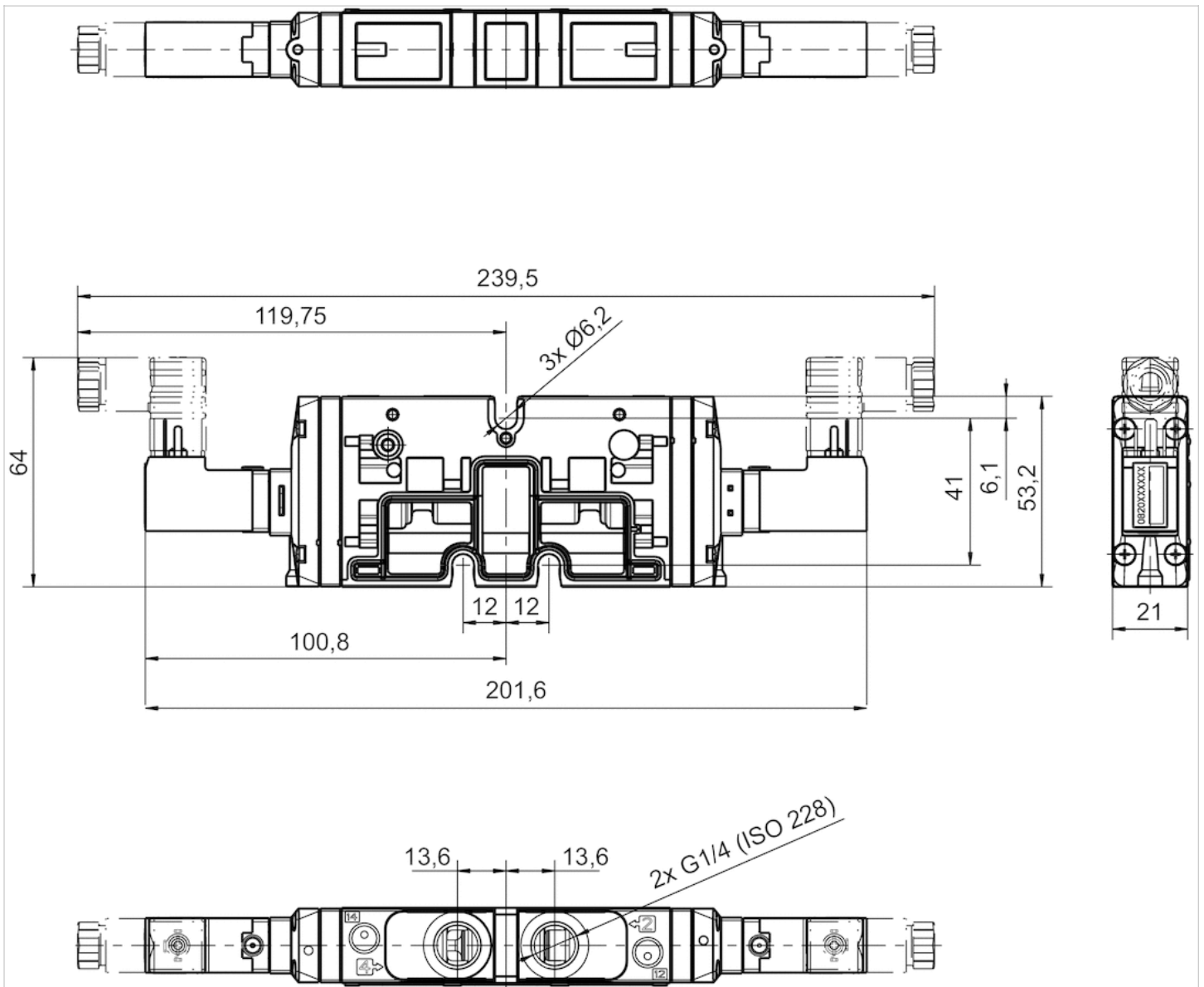





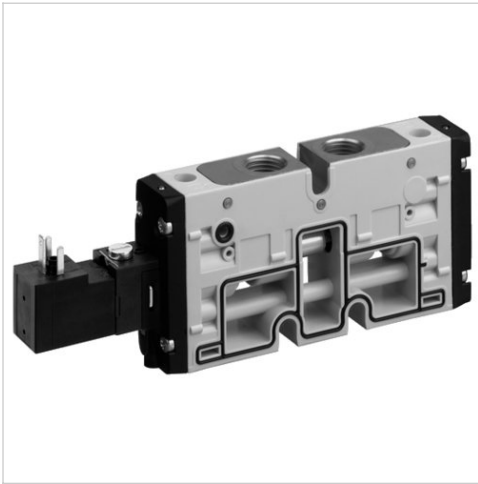

2x3/2-directional valve, Series TC15 - inch

- Q_n = 1100 l/min
- Pilot valve width : 15 mm
- NC/NC NO/NO NC/NO
- Plate connection Pipe connection
- Compressed air connection output : 1/4 - 18 NPTF
- Electrical connection : Plug, ISO 15217, form C
- Can be assembled into blocks
- Manual override : with detent
- double solenoid
- With spring return
- Pilot : External



Version	Spool valve, positive overlapping
Activation	Electrically
Pilot	External
Sealing principle	Soft sealing
Blocking principle	Plate principle
Working pressure min./max.	-0.9 ... 10 bar
Control pressure min./max.	3 ... 10 bar
Ambient temperature min./max.	-10 ... 50 °C
Medium temperature min./max.	-10 ... 50 °C
Medium	Compressed air
Max. particle size	5 µm
Oil content of compressed air	0 ... 5 mg/m ³
Nominal flow Q _n	1100 l/min
Connector standard	ISO 15217
Protection class with connection	IP65
Duty cycle	100 %
Typ. switch-on time	12 ms
Typ. switch-off time	16 ms
Generic emission standard in accordance with	EN 50081-2:1993
Weight	0.25 kg

Technical data

Part No.		MO		Compressed air connection	Operational voltage
				Output	DC
R422102260			NC/NC	1/4 - 18 NPTF	24 V
R422102264			NO/NO	1/4 - 18 NPTF	24 V
R422102268			NC/NO	1/4 - 18 NPTF	24 V

Part No.	Voltage tolerance	Power consumption	Flow conductance	Flow conductance
	DC	DC	b	C-value
R422102260	-10% / +10%	2 W	0.25	5.9 l/(s*bar)
R422102264	-10% / +10%	2 W	0.25	5.9 l/(s*bar)
R422102268	-10% / +10%	2 W	0.25	5.9 l/(s*bar)

Part No.	Nominal resistance
R422102260	185 Ω
R422102264	185 Ω
R422102268	185 Ω

Nominal flow Qn at 6 bar and $\Delta p = 1$ bar, MO = Manual override

Technical information

The min. control pressure must be adhered to, since otherwise faulty switching and valve failure may result!

The pressure dew point must be at least 15 °C under ambient and medium temperature and may not exceed 3 °C .

The oil content of compressed air must remain constant during the life cycle.

Use only the approved oils from AVENTICS. Further information can be found in the "Technical information" document (available in the MediaCentre).

Technical information

Material	
Housing	Polyamide fiber-glass reinforced
Seals	Acrylonitrile butadiene rubber Hydrogenated nitrile butadiene rubber
Front plate	Polyamide fiber-glass reinforced
Threaded bushing	Brass Die cast zinc, nickel-plated chrome-plated

Dimensions

Dimensions

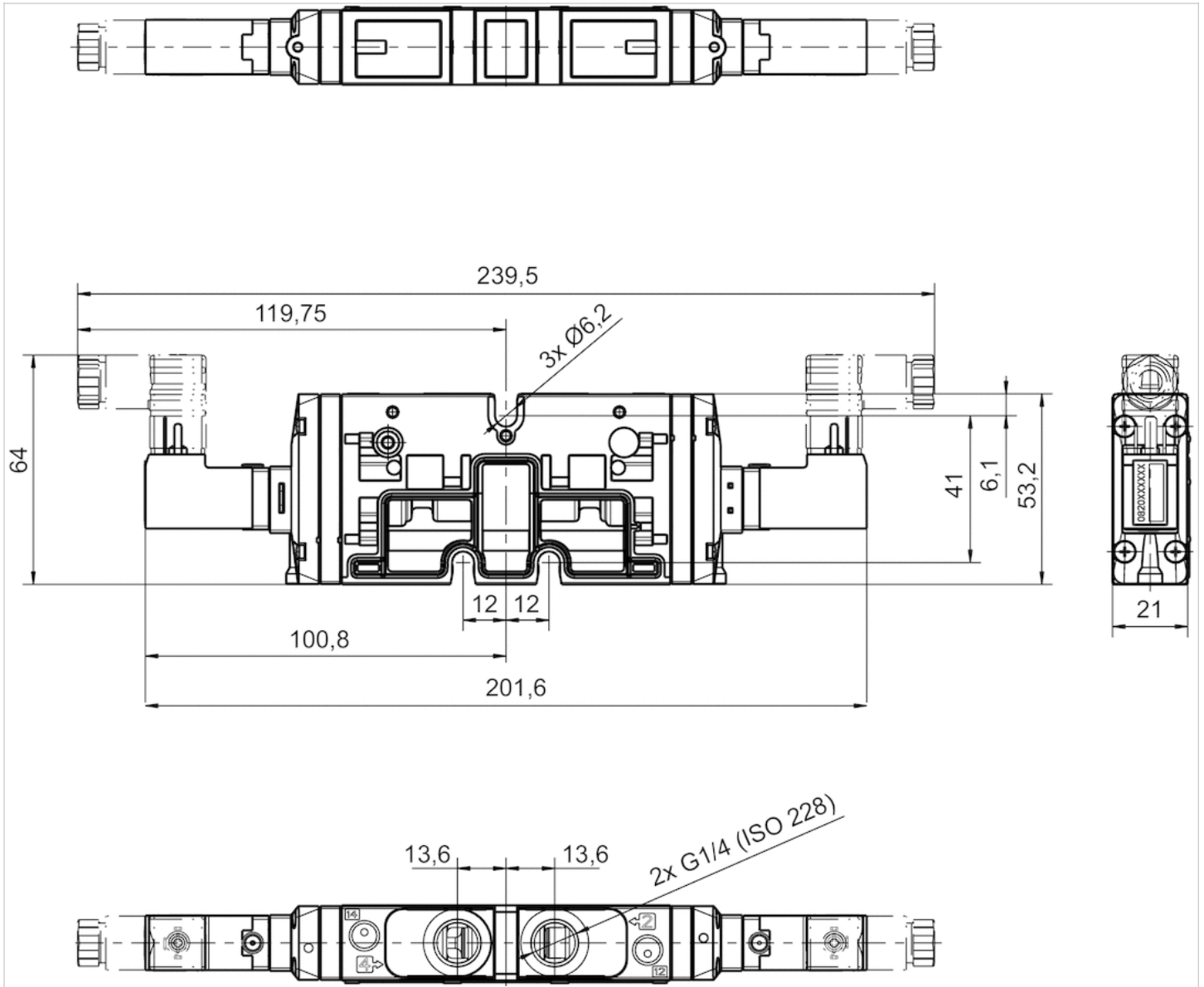







5/2-directional valve, Series TC15 - inch

- 5/2
- Qn = 1500 l/min
- Pilot valve width : 15 mm
- Plate connection Pipe connection
- Compressed air connection output : 1/4 - 18 NPTF
- Electrical connection : Plug, ISO 15217, form C
- Can be assembled into blocks
- Manual override : with detent
- single solenoid double solenoid
- Pilot : External



Version	Spool valve, positive overlapping
Activation	Electrically
Pilot	External
Sealing principle	Soft sealing
Blocking principle	Plate principle
Working pressure min./max.	-0.9 ... 10 bar
Control pressure min./max.	See table below
Ambient temperature min./max.	-10 ... 50 °C
Medium temperature min./max.	-10 ... 50 °C
Medium	Compressed air
Max. particle size	5 µm
Oil content of compressed air	0 ... 1 mg/m ³
Nominal flow Qn	1500 l/min
Compressed air connection	according to ANSI B1.20.3
Connector standard	ISO 15217
Protection class with connection	IP65
Duty cycle	100 %
Generic emission standard in accordance with	EN 50081:1992
Rail mounting DIN EN 60715	TH35 x 15
Weight	See table below

Technical data

Part No.		MO	Compressed air connection	Operational voltage
			Output	DC
R422101177			1/4 - 18 NPTF	24 V
R422101181			1/4 - 18 NPTF	24 V
R422101185			1/4 - 18 NPTF	24 V

Part No.	Voltage tolerance	Power consumption	Flow conductance	Flow conductance
	DC	DC	b	C-value
R422101177	-10% / +10%	2 W	0.33	6.8 l/(s*bar)
R422101181	-10% / +10%	2 W	0.33	6.8 l/(s*bar)
R422101185	-10% / +10%	2 W	0.33	6.8 l/(s*bar)

Part No.	Nominal resistance	Control pressure min./max.	Typ. switch-on time	Typ. switch-off time	Weight
R422101177	185 Ω	2.5 ... 10 bar	22 ms	20 ms	0.201 kg
R422101181	185 Ω	3 ... 10 bar	12 ms	35 ms	0.201 kg
R422101185	185 Ω	2 ... 10 bar	11 ms	11 ms	0.229 kg

Nominal flow Q_n at 6 bar and $\Delta p = 1$ bar, MO = Manual override

Technical information

The min. control pressure must be adhered to, since otherwise faulty switching and valve failure may result!

The pressure dew point must be at least 15 °C under ambient and medium temperature and may not exceed 3 °C .

The oil content of compressed air must remain constant during the life cycle.

Use only the approved oils from AVENTICS. Further information can be found in the "Technical information" document (available in the MediaCentre).

Technical information

Material	
Housing	Polyamide fiber-glass reinforced
Seals	Acrylonitrile butadiene rubber Hydrogenated nitrile butadiene rubber
Front plate	Polyamide fiber-glass reinforced
Threaded bushing	Brass Die cast zinc, nickel-plated chrome-plated

Dimensions

Dimensions

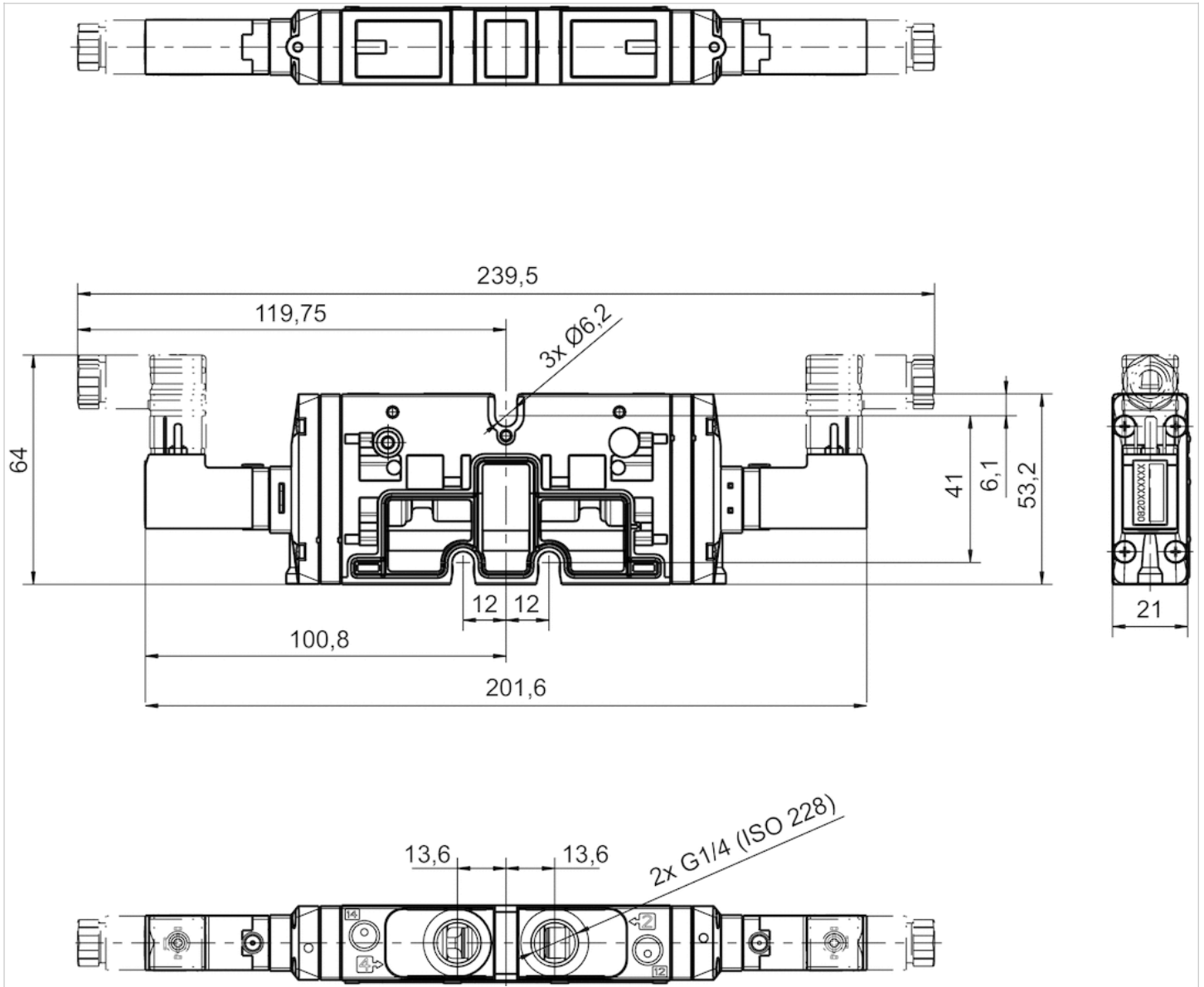







5/3-directional valve, Series TC15 - inch

- 5/3
- $Q_n = 1300 \text{ l/min}$
- Pilot valve width : 15 mm
- Plate connection Pipe connection
- Compressed air connection output : 1/4 - 18 NPTF
- Electrical connection : Plug, ISO 15217, form C
- Can be assembled into blocks
- Manual override : with detent
- double solenoid
- With spring return
- Pilot : External

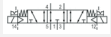

Version	Spool valve, positive overlapping
Activation	Electrically
Pilot	External
Sealing principle	Soft sealing
Blocking principle	Plate principle
Working pressure min./max.	-0.9 ... 10 bar
Control pressure min./max.	3 ... 10 bar
Ambient temperature min./max.	-10 ... 50 °C
Medium temperature min./max.	-10 ... 50 °C
Medium	Compressed air
Max. particle size	5 μm
Oil content of compressed air	0 ... 1 mg/m^3
Nominal flow Q_n	1300 l/min
Compressed air connection	according to ANSI B1.20.3
Connector standard	ISO 15217
Protection class with connection	IP65
Duty cycle	100 %
Typ. switch-on time	12 ms
Typ. switch-off time	13 ms
Generic emission standard in accordance with	EN 50081:1992
Rail mounting DIN EN 60715	TH35 x 15
Weight	0.244 kg

Technical data

Part No.		MO	Compressed air connection	Operational voltage
			Output	DC
R422101189			1/4 - 18 NPTF	24 V
R422101193			1/4 - 18 NPTF	24 V
R422101197			1/4 - 18 NPTF	24 V

Part No.	Voltage tolerance	Power consumption	Flow conductance	Flow conductance
	DC	DC	b	C-value
R422101189	-10% / +10%	2 W	0.31	5.9 l/(s*bar)
R422101193	-10% / +10%	2 W	0.31	5.9 l/(s*bar)

Part No.	Voltage tolerance	Power consumption	Flow conductance	Flow conductance
	DC	DC	b	C-value
R422101197	-10% / +10%	2 W	0.31	5.9 l/(s*bar)

Part No.	Nominal resistance
R422101189	185 Ω
R422101193	185 Ω
R422101197	185 Ω

Nominal flow Qn at 6 bar and $\Delta p = 1$ bar, MO = Manual override

Technical information

The min. control pressure must be adhered to, since otherwise faulty switching and valve failure may result!

The pressure dew point must be at least 15 °C under ambient and medium temperature and may not exceed 3 °C .

The oil content of compressed air must remain constant during the life cycle.

Use only the approved oils from AVENTICS. Further information can be found in the "Technical information" document (available in the MediaCentre).

Technical information

Material	
Housing	Polyamide fiber-glass reinforced
Seals	Acrylonitrile butadiene rubber Hydrogenated nitrile butadiene rubber
Front plate	Polyamide fiber-glass reinforced
Threaded bushing	Brass Die cast zinc, nickel-plated chrome-plated

Dimensions

Dimensions

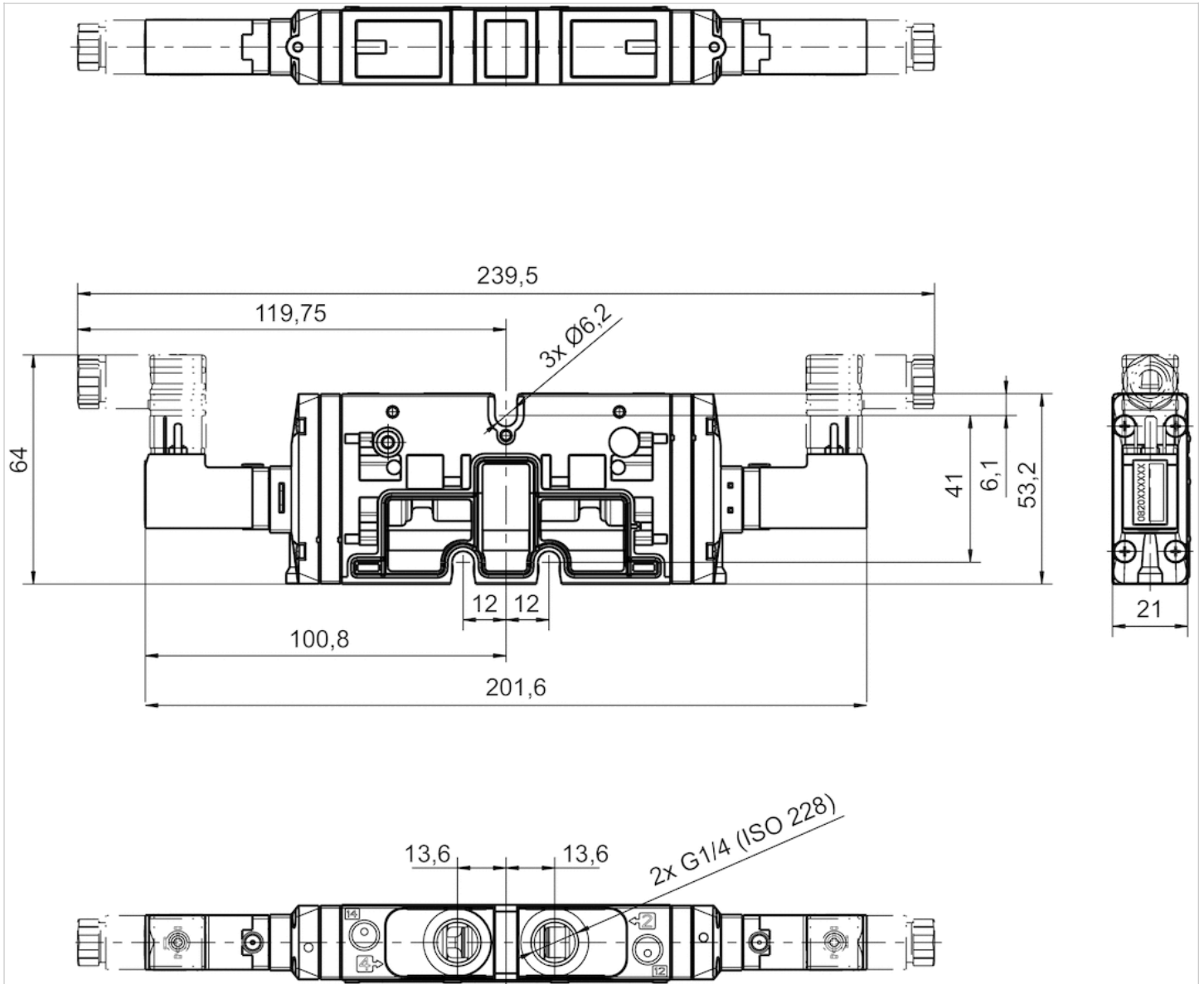



2x3/2-directional valve, Series TC15

- Qn = 1100 l/min
- Compressed air connection output G 1/4
- Plate connection Pipe connection



Version	Spool valve
Activation	pneumatically
Sealing principle	Soft sealing
Blocking principle	Plate principle
Flow rate value Qn	1100 l/min
Working pressure min./max.	-0.9 ... 10 bar
Control pressure min./max.	3 ... 10 bar
Ambient temperature min./max.	-10 ... 50 °C
Medium temperature min./max.	-10 ... 50 °C
Medium	Compressed air
Max. particle size	5 µm
Oil content of compressed air	0 ... 5 mg/m ³
Mounting screw tightening torque	2.5 Nm
Weight	0.18 kg

Technical data

Part No.			Compressed air connection	
			Output	Pilot control exhaust
R422102232		NC/NC	G 1/4	M5
R422102233		NO/NO	G 1/4	M5
R422102234		NC/NO	G 1/4	M5

Part No.	Flow conductance	
	b	C-value
R422102232	0.25	5.9 l/(s*bar)
R422102233	0.25	5.9 l/(s*bar)
R422102234	0.25	5.9 l/(s*bar)

Nominal flow Qn at 6 bar and $\Delta p = 1$ bar

Technical information

The min. control pressure must be adhered to, since otherwise faulty switching and valve failure may result!
 The pressure dew point must be at least 15 °C under ambient and medium temperature and may not exceed 3 °C .
 The oil content of compressed air must remain constant during the life cycle.
 Use only the approved oils from AVENTICS. Further information can be found in the "Technical information" document (available in the MediaCentre).

Technical information

Material	
Housing	Polyamide fiber-glass reinforced
Seals	Acrylonitrile butadiene rubber

Material	
Front plate	Polyamide fiber-glass reinforced
Threaded bushing	Brass Die cast zinc, chrome-plated nickel-plated





5/2-directional valve, Series TC15

- Qn = 1500 l/min
- Compressed air connection output G 1/4
- Plate connection Pipe connection



Version	Spool valve, positive overlapping
Activation	pneumatically
Pilot	External
Sealing principle	Soft sealing
Blocking principle	Plate principle
Flow rate value Qn	1500 l/min
Working pressure min./max.	See table below
Control pressure min./max.	See table below
Ambient temperature min./max.	-10 ... 50 °C
Medium temperature min./max.	-10 ... 50 °C
Medium	Compressed air
Max. particle size	5 µm
Oil content of compressed air	0 ... 1 mg/m ³
Rail mounting DIN EN 60715	TH35 x 15
Weight	0.159 kg

Technical data

Part No.		Compressed air connection	
		Input	Output
0820258703		G 1/4	G 1/4
0820258701		G 1/4	G 1/4
0820258702		G 1/4	G 1/4
0820258704		G 1/4	G 1/4

Part No.	Compressed air connection		Flow conductance
	Exhaust	Pilot control exhaust	b
0820258703	G 1/4	M5	0.33
0820258701	G 1/4	M5	0.33
0820258702	G 1/4	M5	0.33
0820258704	G 1/4	M5	0.33

Part No.	Flow conductance		Working pressure min./max.	Control pressure min./max.
	C-value			
0820258703	6.8 l/(s*bar)		-0.9 ... 10 bar	2 ... 10 bar
0820258701	6.8 l/(s*bar)		2.5 ... 10 bar	2.5 ... 10 bar
0820258702	6.8 l/(s*bar)		3 ... 10 bar	3 ... 10 bar
0820258704	6.8 l/(s*bar)		-0.9 ... 10 bar	2.5 ... 10 bar

Nominal flow Qn at 6 bar and $\Delta p = 1$ bar

Technical information

The min. control pressure must be adhered to, since otherwise faulty switching and valve failure may result!
 The pressure dew point must be at least 15 °C under ambient and medium temperature and may not exceed 3 °C .
 The oil content of compressed air must remain constant during the life cycle.
 Use only the approved oils from AVENTICS. Further information can be found in the “Technical information” document (available in the MediaCentre).

Technical information

Housing	Polyamide fiber-glass reinforced
Front plate	Polyamide fiber-glass reinforced

Diagrams

Control pressure

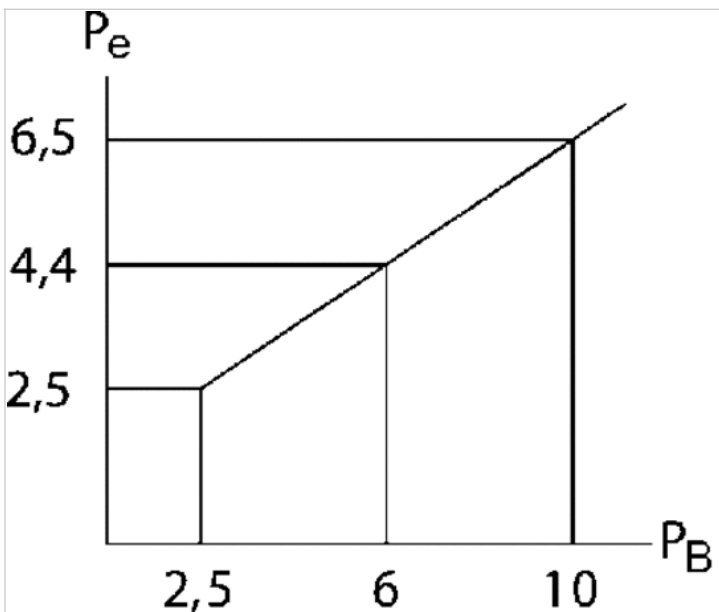

Pe = external control pressure, min.
 PB= Working pressure



5/3-directional valve, Series TC15

- Qn = 1300 l/min
- Compressed air connection output G 1/4
- Plate connection Pipe connection

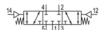

Version	Spool valve, positive overlapping
Activation	pneumatically
Pilot	External
Sealing principle	Soft sealing
Blocking principle	Plate principle
Flow rate value Qn	1300 l/min
Working pressure min./max.	-0.9 ... 10 bar
Control pressure min./max.	3 ... 10 bar
Ambient temperature min./max.	-10 ... 50 °C
Medium temperature min./max.	-10 ... 50 °C
Max. particle size	5 µm
Oil content of compressed air	0 ... 1 mg/m ³
Rail mounting DIN EN 60715	TH35 x 15
Weight	0.174 kg

Technical data

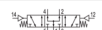
Part No.			Compressed air connection	
			Input	
0820259701		closed center	G 1/4	
0820259702		exhausted center	G 1/4	
0820259703		pressurized center	G 1/4	

Part No.	Compressed air connection	
	Output	Exhaust
0820259701	G 1/4	G 1/4
0820259702	G 1/4	G 1/4
0820259703	G 1/4	G 1/4

Part No.	Compressed air connection		Flow conductance	Flow conductance
	Pilot control exhaust		b	C-value
0820259701	M5		0.31	5.9 l/(s*bar)
0820259702	M5		0.31	5.9 l/(s*bar)
0820259703	M5		0.31	5.9 l/(s*bar)

Nominal flow Qn at 6 bar and $\Delta p = 1$ bar

Technical information

The min. control pressure must be adhered to, since otherwise faulty switching and valve failure may result!

The pressure dew point must be at least 15 °C under ambient and medium temperature and may not exceed 3 °C .

The oil content of compressed air must remain constant during the life cycle.

Use only the approved oils from AVENTICS. Further information can be found in the "Technical information" document (available in the MediaCentre).

Technical information

Housing	Polyamide fiber-glass reinforced
Front plate	Polyamide fiber-glass reinforced

Diagrams

Control pressure

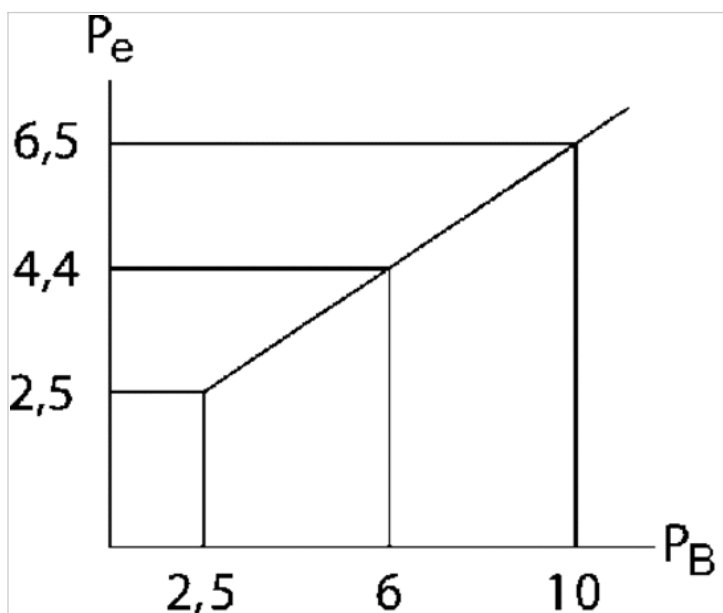

P_e = external control pressure, min.

P_B = Working pressure

Valve plug connector, series CON-VP

- Socket form C 2+E angled 90°
- open cable ends 3-pin
- with cable
- unshielded

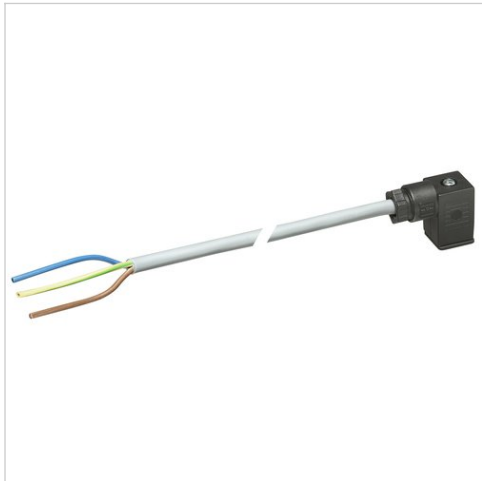

Ambient temperature min./max.	-20 ... 80 °C
Operational voltage	See table below
Protection class	IP67
Wire cross-section	0.75 mm ²
Mounting screw tightening torque	0.4 Nm
Weight	See table below

Technical data

Part No.		Operational voltage	Max. current	Protective circuit	Contact assignment
1834484212		230 V AC/DC	6 A	-	2+E
1834484213		230 V AC/DC	6 A	-	2+E
1834484214		230 V AC/DC	6 A	-	2+E
1834484215		230 V AC/DC	6 A	-	2+E
1834484204		24 V AC/DC	6 A	Z-diode	2+E
1834484205		24 V AC/DC	6 A	Z-diode	2+E
1834484206		24 V AC/DC	6 A	Z-diode	2+E
1834484207		24 V AC/DC	6 A	Z-diode	2+E
1834484208		230 V AC/DC	6 A	Varistor	2+E
1834484209		230 V AC/DC	6 A	Varistor	2+E
1834484210		230 V AC/DC	6 A	Varistor	2+E
1834484211		230 V AC/DC	6 A	Varistor	2+E
1834484236		24 V AC/DC	6 A	Z-diode	2+E

Part No.	LED status display	Number of wires	Cable-Ø	Cable length	Weight	Fig.	
1834484212	-	3	5.9 mm	3 m	0.183 kg	Fig. 1	-
1834484213	-	3	5.9 mm	3 m	0.183 kg	Fig. 2	-
1834484214	-	3	5.9 mm	5 m	0.308 kg	Fig. 1	-
1834484215	-	3	5.9 mm	5 m	0.308 kg	Fig. 2	-
1834484204	Yellow	3	5.9 mm	3 m	0.185 kg	Fig. 1	1)
1834484205	Yellow	3	5.9 mm	3 m	0.185 kg	Fig. 2	1)
1834484206	Yellow	3	5.9 mm	5 m	0.292 kg	Fig. 1	1)
1834484207	Yellow	3	5.9 mm	5 m	0.298 kg	Fig. 2	1)
1834484208	Yellow	3	5.9 mm	3 m	0.171 kg	Fig. 1	1)
1834484209	Yellow	3	5.9 mm	3 m	0.194 kg	Fig. 2	1)
1834484210	Yellow	3	5.9 mm	5 m	0.297 kg	Fig. 1	1)

Part No.	LED status display	Number of wires	Cable-Ø	Cable length	Weight	Fig.	
1834484211	Yellow	3	5.9 mm	5 m	0.285 kg	Fig. 2	1)
1834484236	Yellow	3	5.9 mm	10 m	0.571 kg	Fig. 2	1)

1) Scope of delivery incl. flat gasket

Technical information

The specified protection class is only valid in assembled and tested state.

Technical information

Material	
Seals	caoutchouc/butadiene caoutchouc
Cable sheath	Polyvinyl chloride

Dimensions

Fig. 1

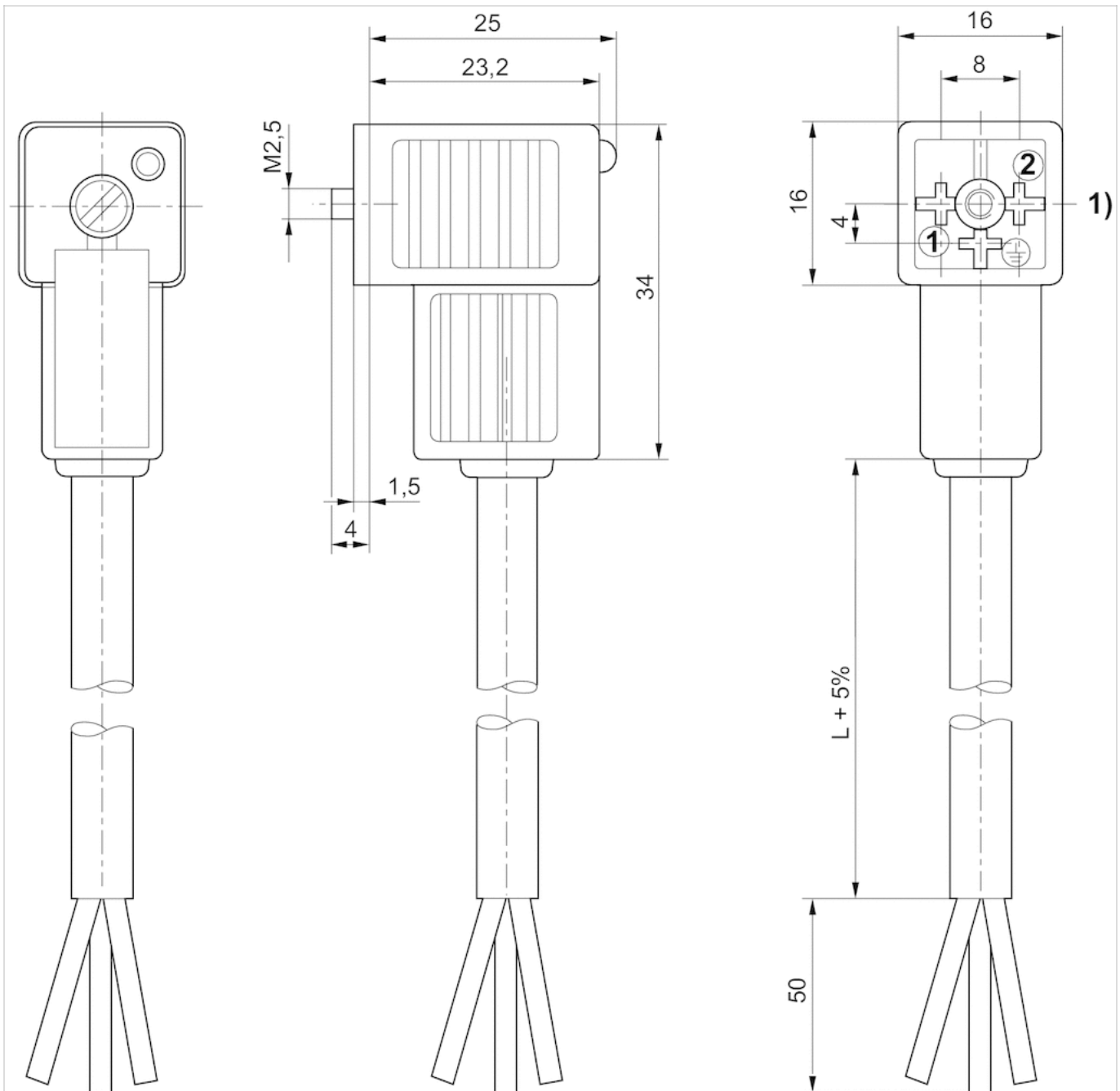

1) 0° female insert

Fig. 2

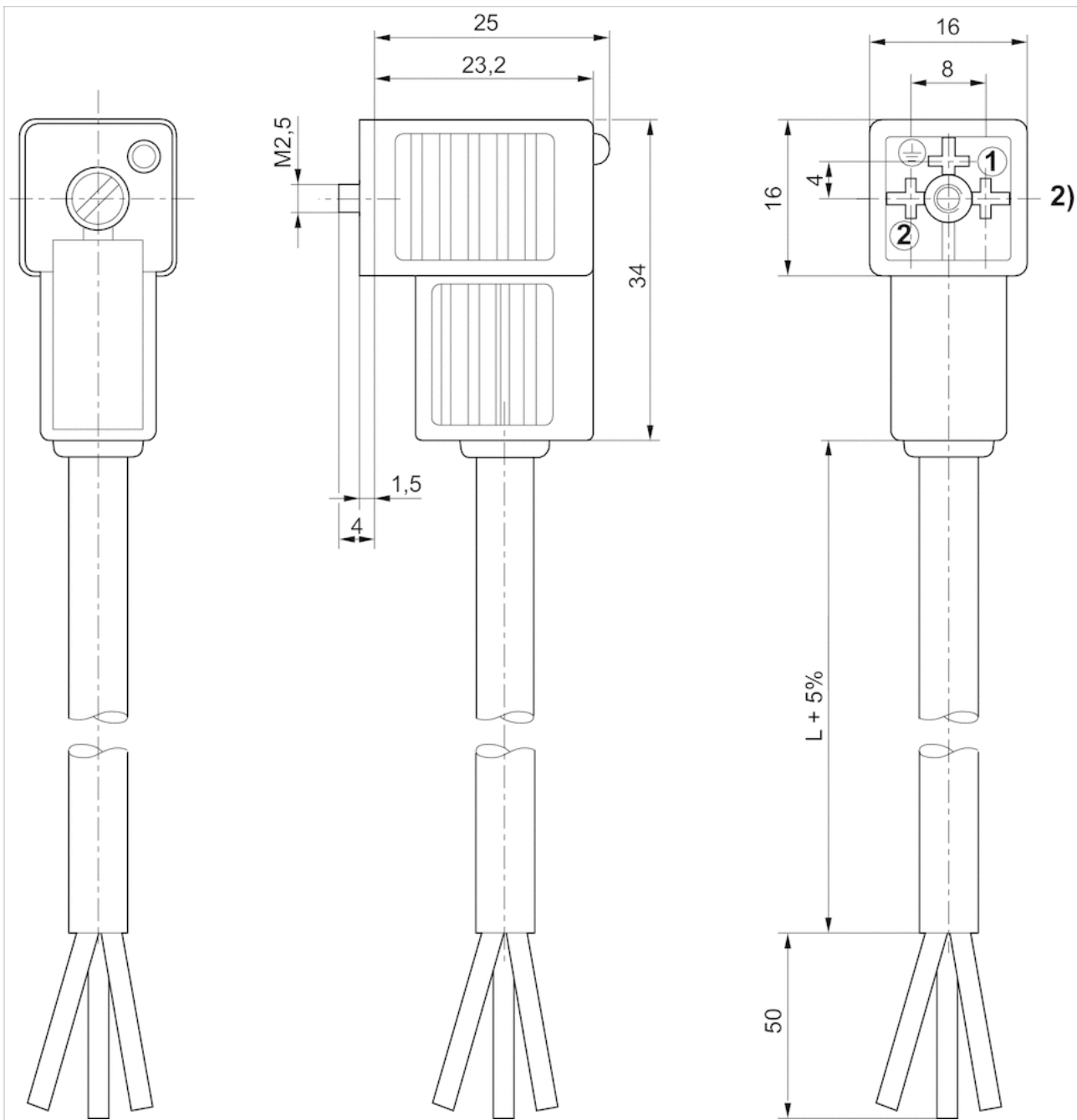

2) 180° female insert

Valve plug connector, series CON-VP

- Socket, form C, 2+E, angled, 90°
- ISO 15217
- unshielded
- with LED Green



Connection type	Screws
Ambient temperature min./max.	-40 ... 90 °C
Operational voltage	See table below
Protection class	IP65
Mounting screw tightening torque	0.4 Nm
Weight	See table below

Technical data

Part No.		Operational voltage	Max. current	Protective circuit	Contact assignment
1834484187		250 / 300 V AC/DC	6 A	-	2+E
4402050330		24 V AC/DC	-	Z-diode	2+E

Part No.	LED status display	suitable cable-Ø min./max	Seal	Weight
1834484187	-	4 / 8 mm	caoutchouc/butadiene caoutchouc	0.012 kg
4402050330	Green	-	-	0.014 kg

Part No.	Fig.	
1834484187	Fig. 1	-
4402050330	Fig. 3	1)

1)

Technical information

The specified protection class is only valid in assembled and tested state.

Technical information

Material	
Seals	caoutchouc/butadiene caoutchouc

Dimensions

Fig. 1

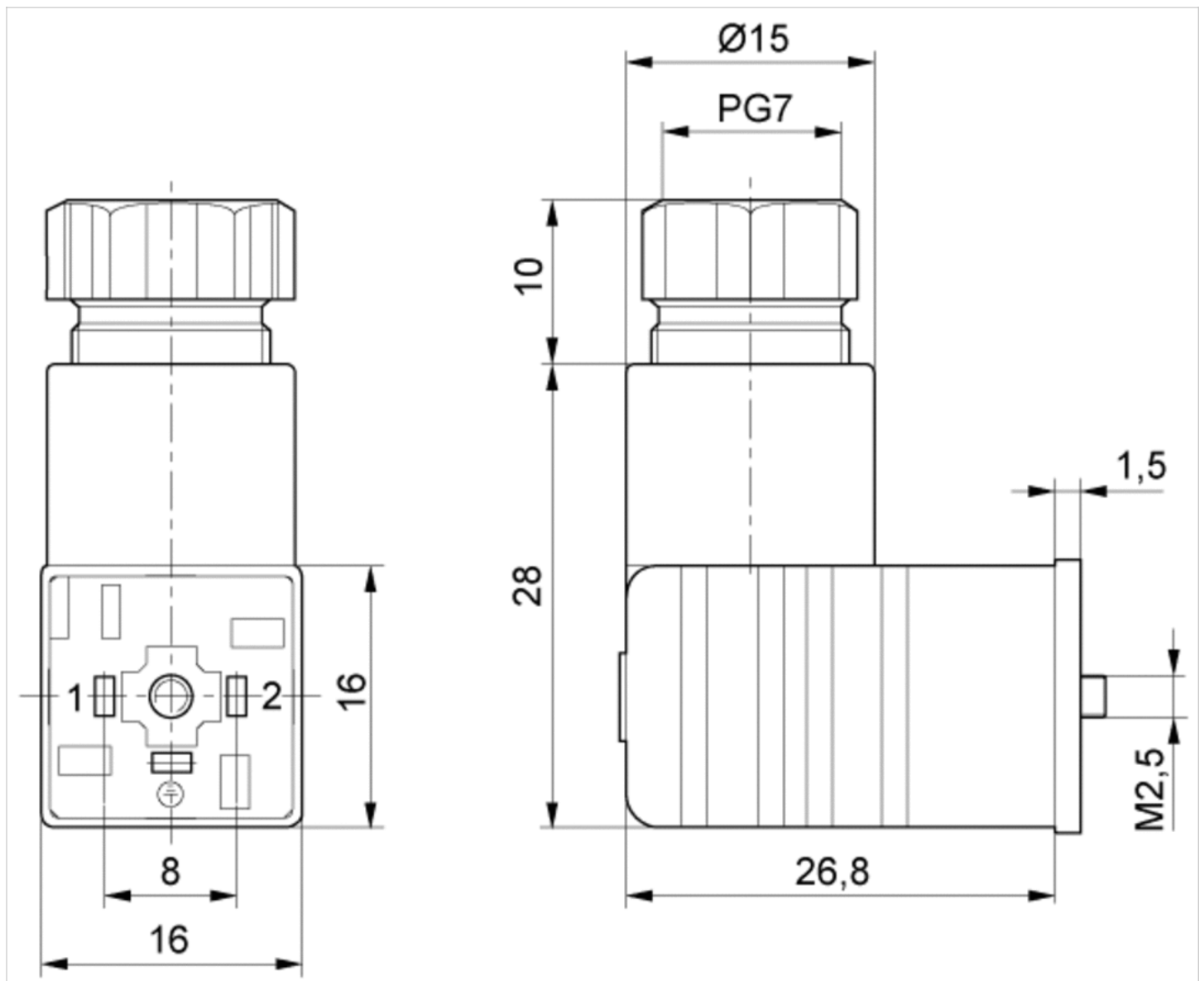

Fig. 2

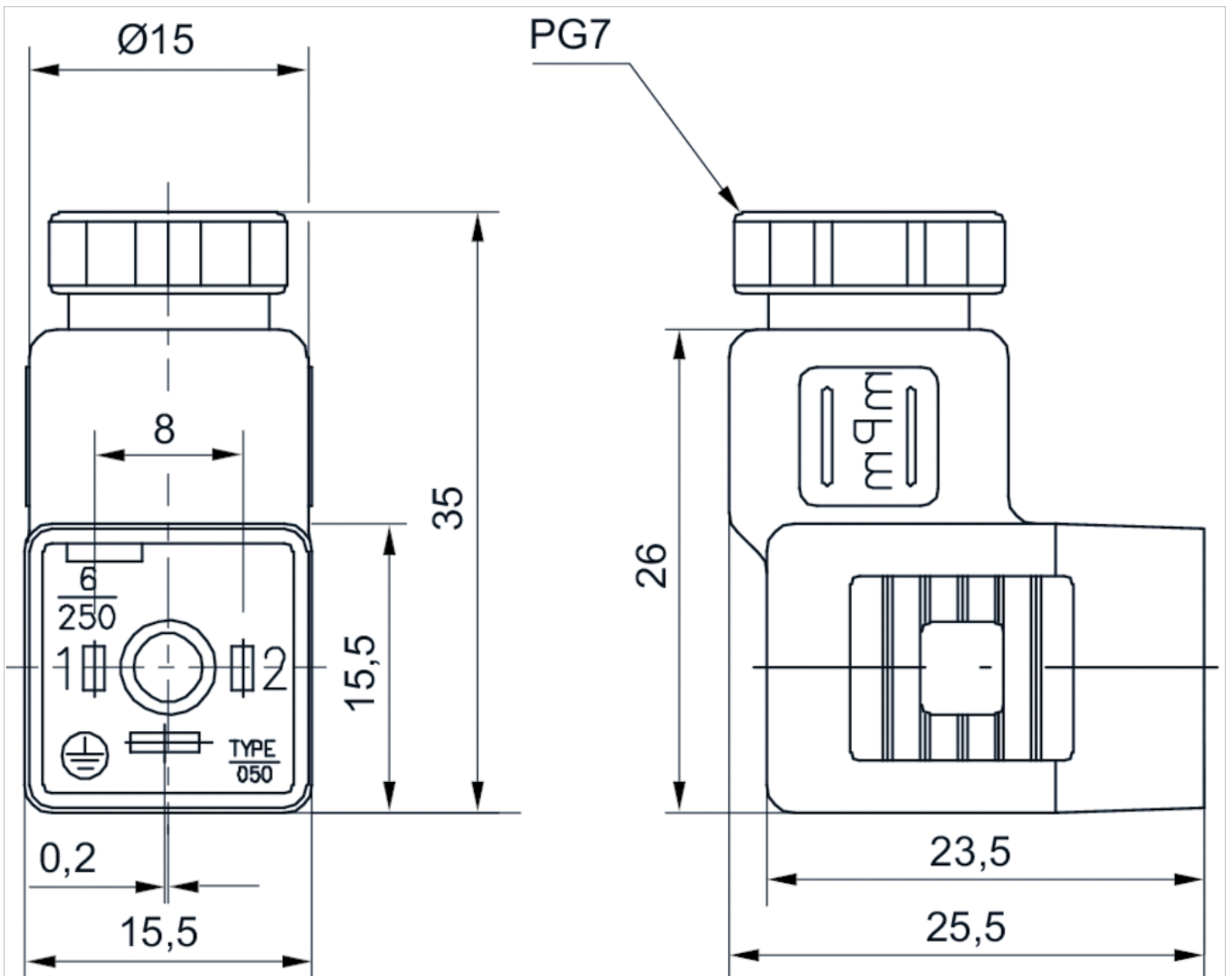
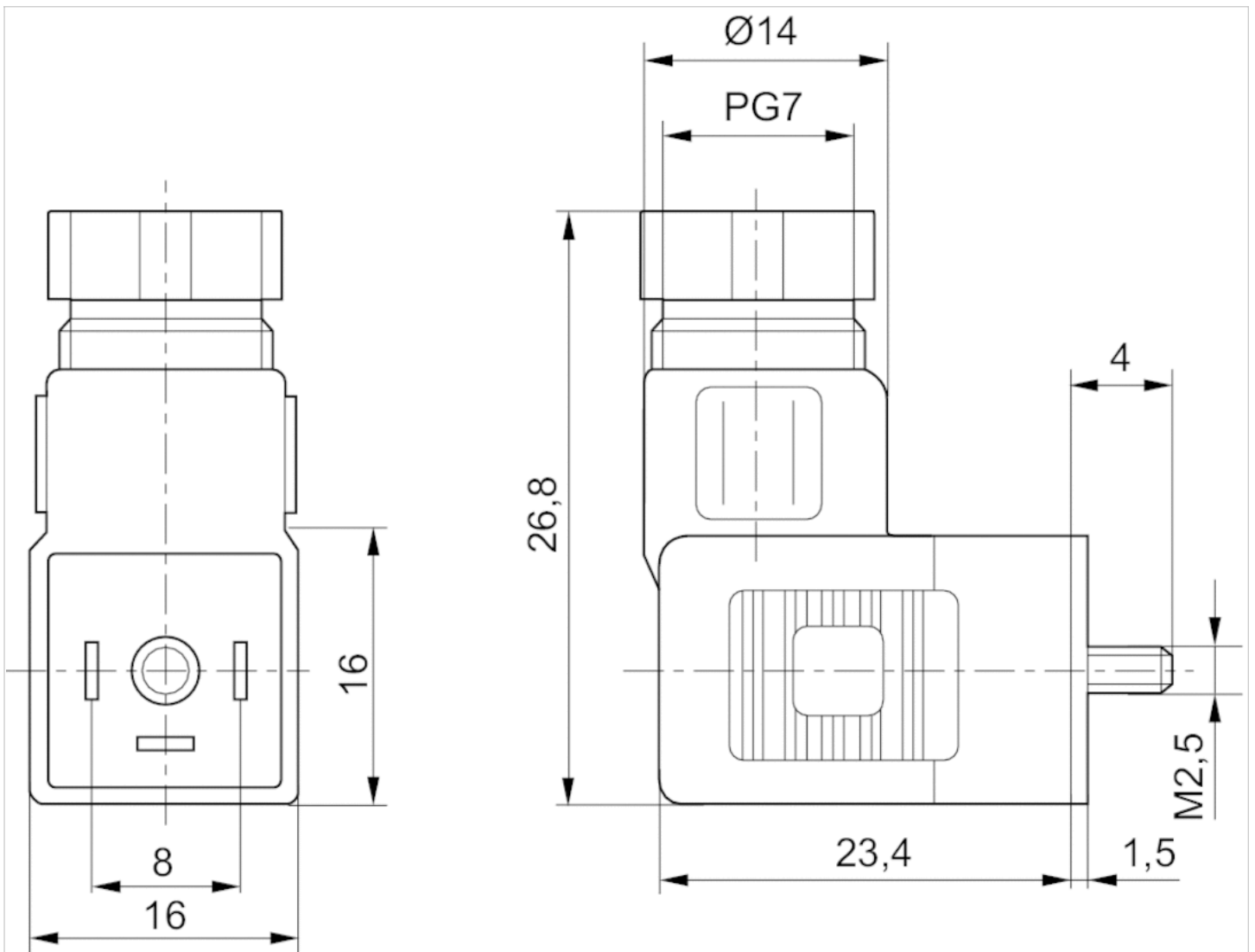

Fig. 3



Coil, Series C01

- Form C, coil kit
- Coil width 15 mm
- Power consumption DC 2 W
- Holding power AC 1.6 VA
- Switch-on power AC 2.2 VA



Connector standard	ISO 15217
electrical connections	Plug, 3-pin
Ambient temperature min./max.	-10 ... 50 °C
Protection class With valve plug connector/plug	IP65
Duty cycle ED	100 %
Weight	See table below

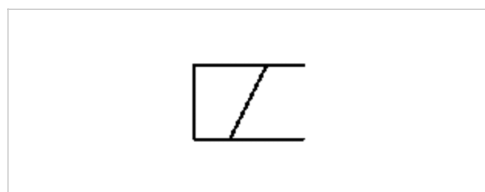

Technical data

Part No.	Operational voltage	Operational voltage	Operational voltage
	DC	AC 50 Hz	AC 60 Hz
R422101598	-	110 V	110 V
R422101599	-	230 V	230 V
R422101600	24 V	-	-
R422101601	-	24 V	24 V
R422101602	12 V	-	-

Part No.	Voltage tolerance	Voltage tolerance	Voltage tolerance	Power consumption
	DC	AC 50 Hz	AC 60 Hz	DC
R422101598	-	-10% / +10%	-10% / +10%	-
R422101599	-	-10% / +10%	-10% / +10%	-
R422101600	-10% / +10%	-	-	2 W
R422101601	-	-10% / +10%	-10% / +10%	-
R422101602	-10% / +10%	-	-	2 W

Part No.	Holding power	Holding power	Switch-on power	Switch-on power	Weight	
	AC 50 Hz	AC 60 Hz	AC 50 Hz	AC 60 Hz		
R422101598	1.6 VA	1.4 VA	2.2 VA	2 VA	0.023 kg	1)
R422101599	1.6 VA	1.4 VA	2.2 VA	2 VA	0.022 kg	1)
R422101600	-	-	-	-	0.024 kg	-
R422101601	1.6 VA	1.4 VA	2.2 VA	2 VA	0.023 kg	1)

Part No.	Holding power	Holding power	Switch-on power	Switch-on power	Weight	
	AC 50 Hz	AC 60 Hz	AC 50 Hz	AC 60 Hz		
R422101602	-	-	-	-	0.024 kg	-

1) Can only be combined with TC series base valves and TC series valves with alternating voltage (AC).

Technical information

Please note that the coils are only compatible with TC series valves that were produced starting in 2011.

Technical information

Material	
Housing	Polyamide

Dimensions

Dimensions

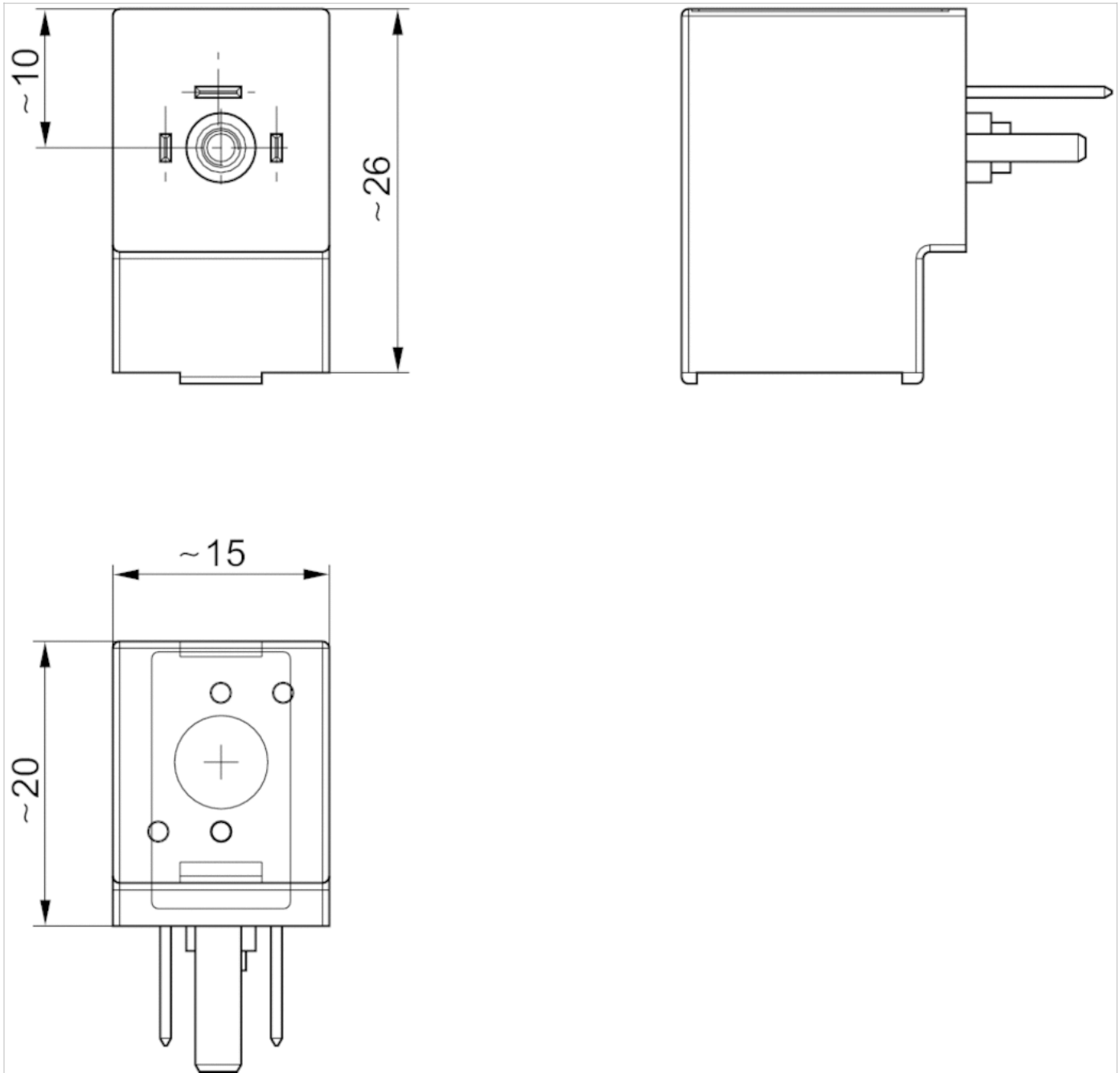

Coil, Series C01

- M8, coil kit
- Coil width 15 mm
- Power consumption DC 2.2 W



Connector standard	DIN EN 60947-5-2
electrical connections	See table below
Ambient temperature min./max.	-10 ... 50 °C
Protection class acc. to DIN EN 61140 Electrically	Class III
Protection class With valve plug connector/plug	IP65
Duty cycle ED	100 %
LED status display	Yellow
Weight	0.025 kg

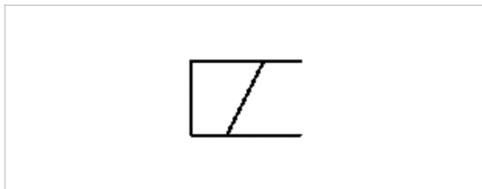

Technical data

Part No.	electrical connections	Operational voltage	Voltage tolerance
		DC	DC
R422101603	Plug, M8x1, 4-pin	24 V	-10% / +10%
R422101604	Plug, M8x1, 3-pin	24 V	-10% / +10%

Part No.	Power consumption
	DC
R422101603	2.2 W
R422101604	2.2 W

Technical information

Please note that the coils are only compatible with TC series valves that were produced starting in 2011.

Technical information

Material	
Housing	Polyamide

Dimensions

Dimensions

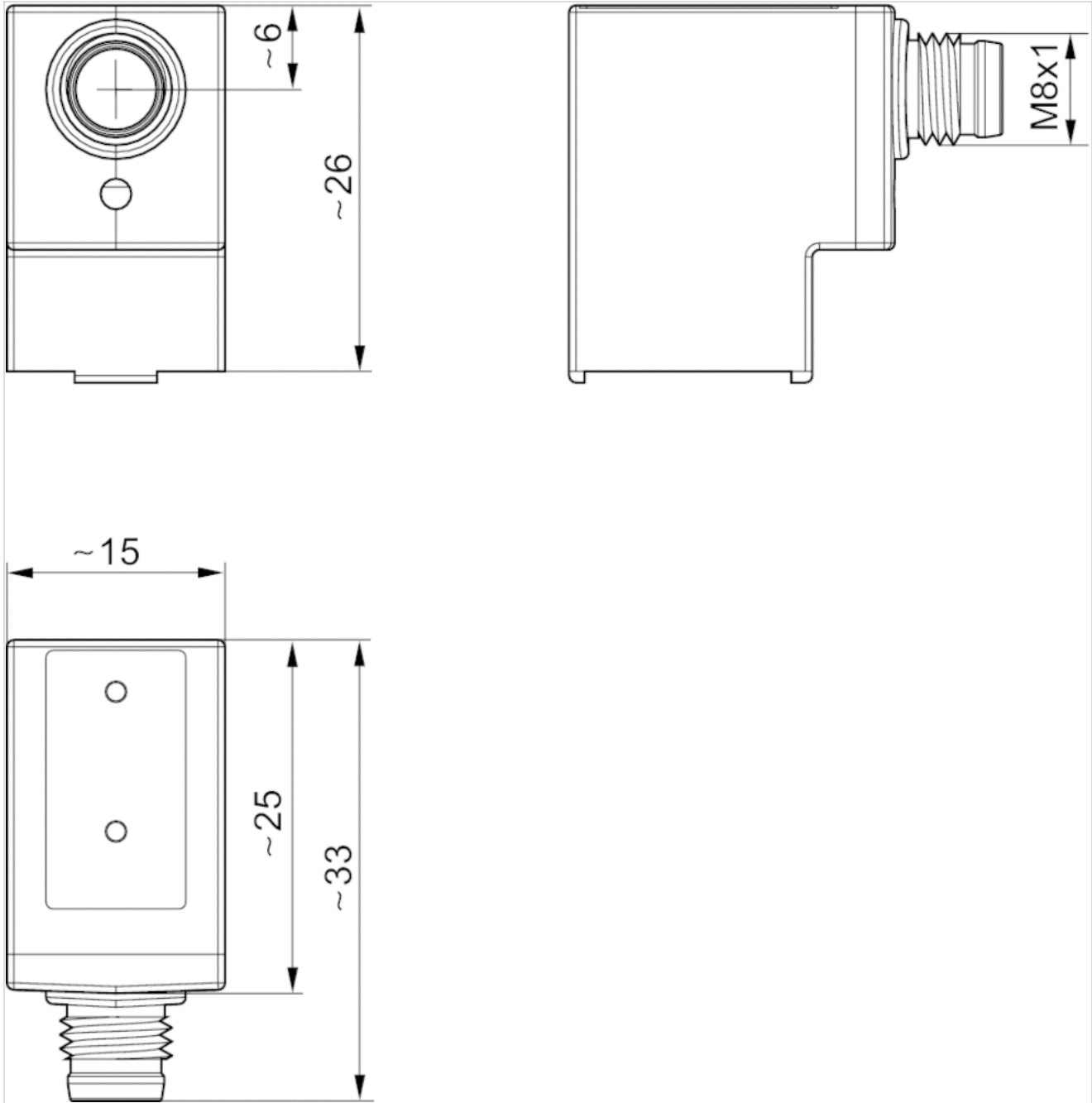

Round plug connector, Series CON-RD

- Socket M8x1 3-pin A-coded straight 180°
- open cable ends
- with cable
- UL (Underwriters Laboratories)
- unshielded



Ambient temperature min./max.	-25 ... 85 °C
Operational voltage	48 V AC/DC
Protection class	IP67
Wire cross-section	0.24 mm ²
Weight	See table below

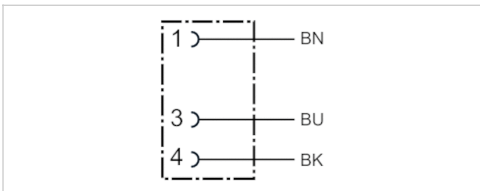

Technical data

Part No.	Max. current	Number of wires	Cable-Ø	Cable length	Certification	Weight
1834484166	4 A	3	4.5 mm	3 m	UL (Underwriters Laboratories)	0.087 kg
1834484168	4 A	3	4.5 mm	5 m	UL (Underwriters Laboratories)	0.141 kg
1834484247	4 A	3	4.5 mm	10 m	UL (Underwriters Laboratories)	0.277 kg

Technical information

The specified protection class is only valid in assembled and tested state.

Technical information

Material	
Housing	Polyurethane
Cable sheath	Polyurethane

Dimensions

Dimensions

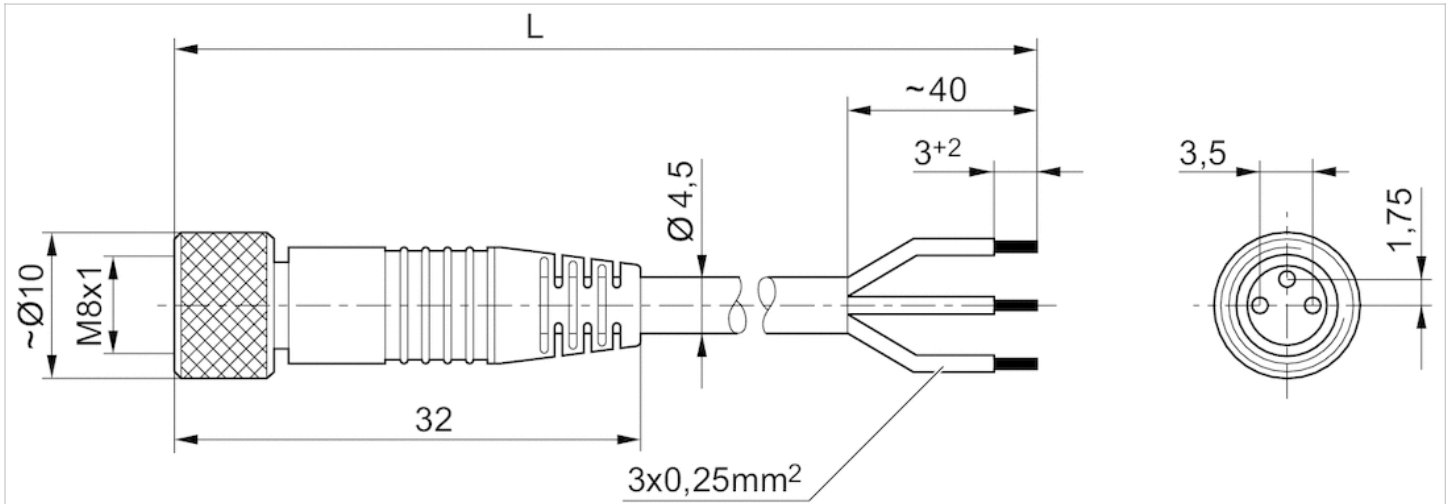

L = length

Pin assignments

Pin assignment, socket

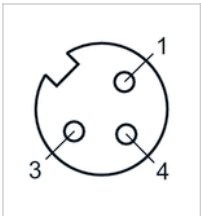

- (1) BN=brown
- (3) BU=blue
- (4) BK=black

Round plug connector, Series CON-RD

- Socket M8x1 3-pin A-coded angled 90°
- open cable ends
- with cable
- unshielded



Ambient temperature min./max.	-40 ... 85 °C
Operational voltage	48 V AC/DC
Protection class	IP67
Wire cross-section	0.24 mm ²
Weight	See table below

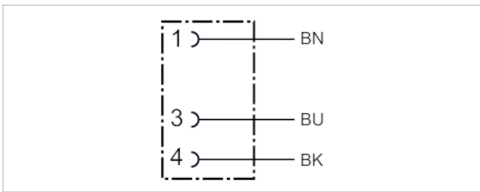

Technical data

Part No.	Max. current	Number of wires	Cable-Ø	Cable length	Weight
1834484167	4 A	3	4.5 mm	3 m	0.087 kg
1834484169	4 A	3	4.5 mm	5 m	0.139 kg
1834484248	4 A	3	4.5 mm	10 m	0.279 kg

Technical information

The specified protection class is only valid in assembled and tested state.

Technical information

Material	
Housing	Polyurethane
Cable sheath	Polyurethane

Dimensions

Dimensions

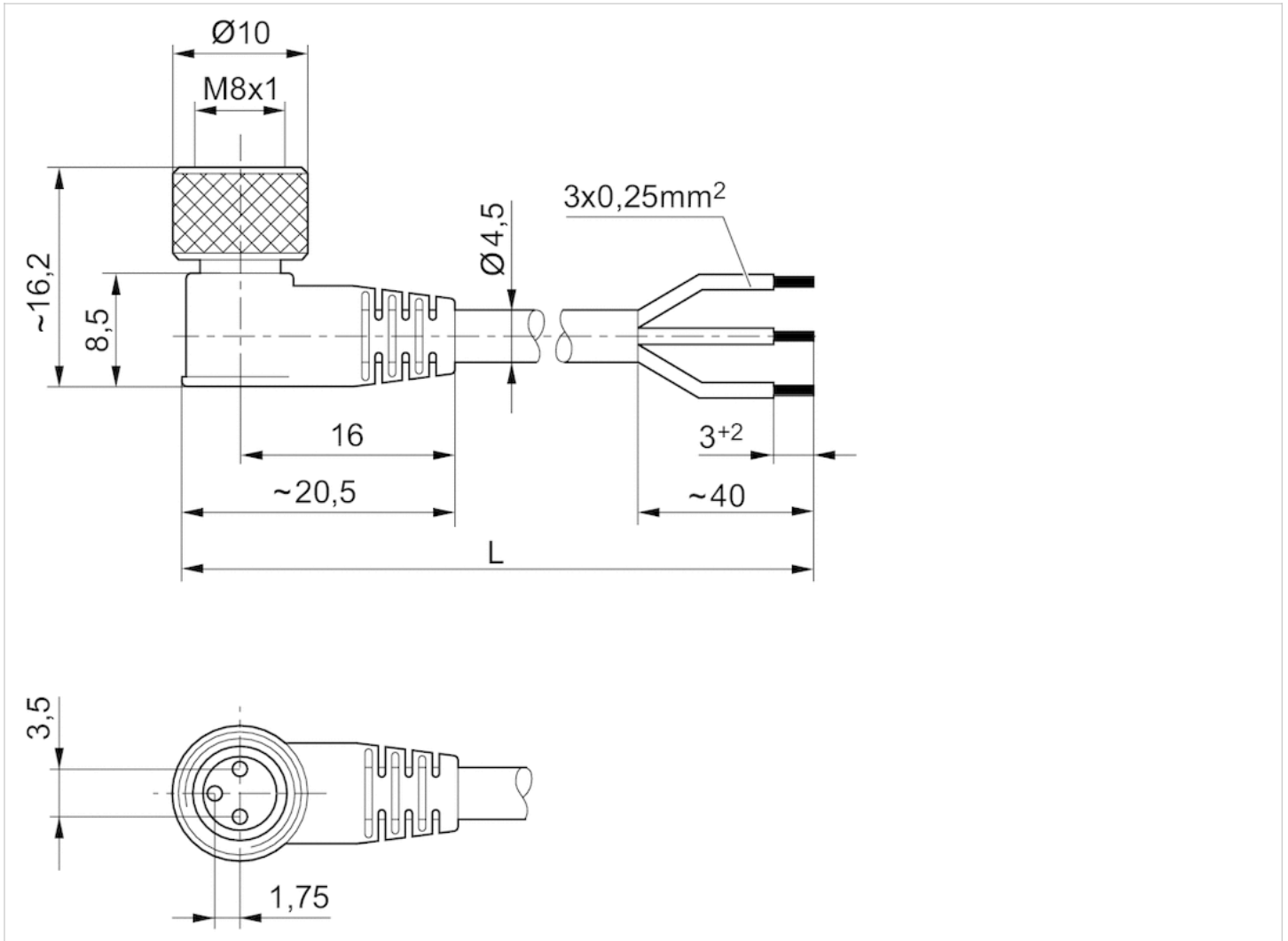

L = length

Pin assignments

Pin assignment, socket

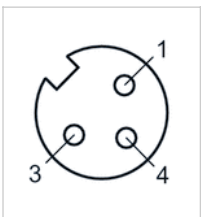

- (1) BN=brown
- (3) BU=blue
- (4) BK=black

Round plug connector, Series CON-RD

- Socket, M8x1, 3-pin, A-coded, straight, 180°
- UL (Underwriters Laboratories)
- unshielded



Connection type	Soldering
Ambient temperature min./max.	-25 ... 80 °C
Operational voltage	48 V AC/DC
Protection class	IP67
Weight	0.009 kg

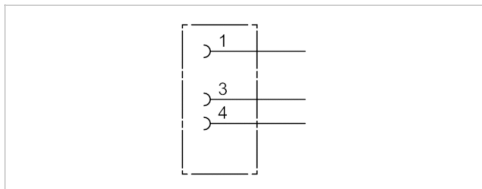

Technical data

Part No.	Max. current	suitable cable-Ø min./max
1834484173	4 A	3.5 / 5 mm

Technical information

The specified protection class is only valid in assembled and tested state.

Technical information

Material	
Housing	Polyamide

Dimensions

Dimensions

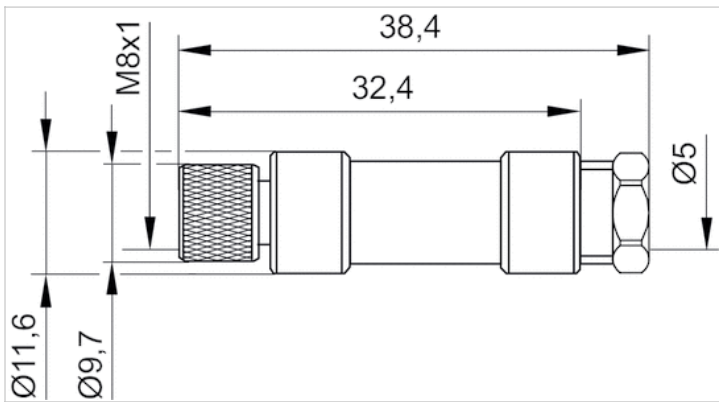

Pin assignments

Pin assignment, socket

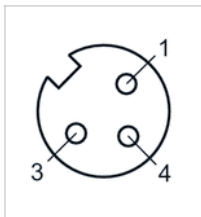

Round plug connector, Series CON-RD

- Socket, M8x1, 3-pin, A-coded, angled, 90°
- UL (Underwriters Laboratories)
- unshielded



Connection type	Soldering
Ambient temperature min./max.	-40 ... 85 °C
Operational voltage	48 V AC/DC
Protection class	IP67
Weight	0.01 kg

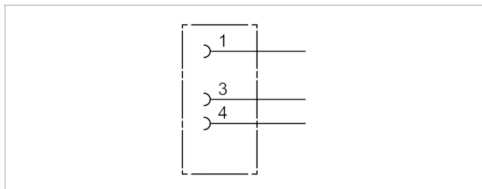

Technical data

Part No.	Max. current	Contact assignment	suitable cable-Ø min./max
1834484174	4 A	3	3.5 / 5 mm

Technical information

The specified protection class is only valid in assembled and tested state.

Technical information

Material	
Housing	Polyamide

Dimensions

Dimensions

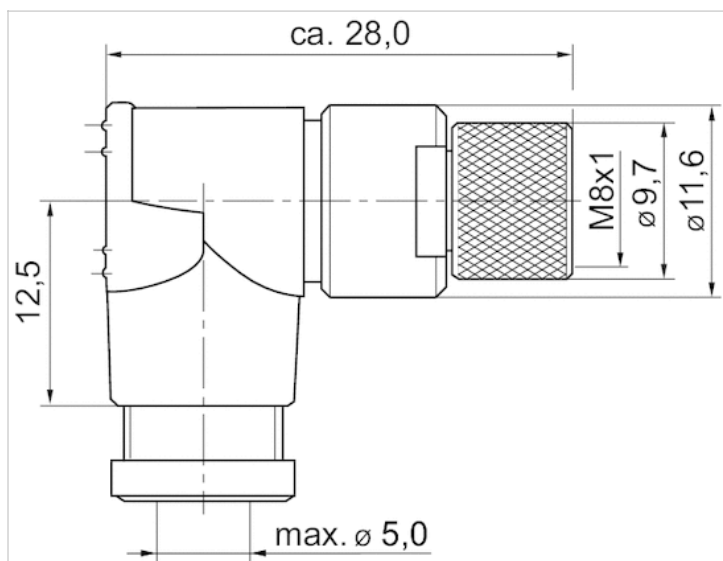

Pin assignments

Pin assignment, socket

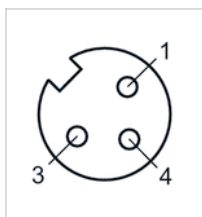

Round plug connector, Series CON-RD

- Socket M8x1 4-pin A-coded straight 180°
- open cable ends
- with cable
- UL (Underwriters Laboratories)
- unshielded

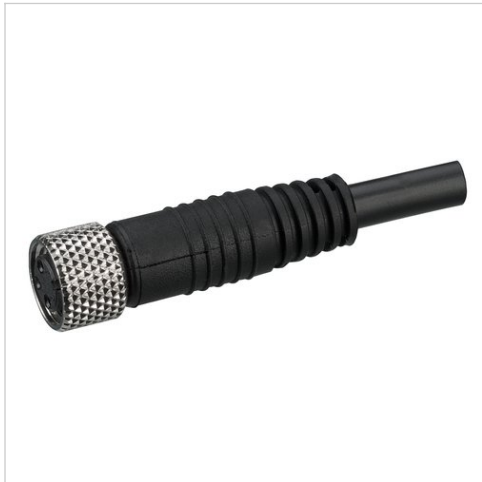

Ambient temperature min./max.	-40 ... 85 °C
Operational voltage	48 V AC/DC
Protection class	IP67
Wire cross-section	0.25 mm ²
Weight	See table below

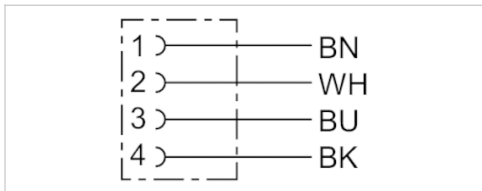

Technical data

Part No.	Max. current	Number of wires	Cable-Ø	Cable length	Certification	Weight
1834484144	4 A	4	4.5 mm	3 m	UL (Underwriters Laboratories)	0.087 kg
1834484146	4 A	4	4.5 mm	5 m	UL (Underwriters Laboratories)	0.14 kg

Technical information

The specified protection class is only valid in assembled and tested state.

Technical information

Material	
Housing	Polyurethane
Cable sheath	Polyurethane

Dimensions

Dimensions

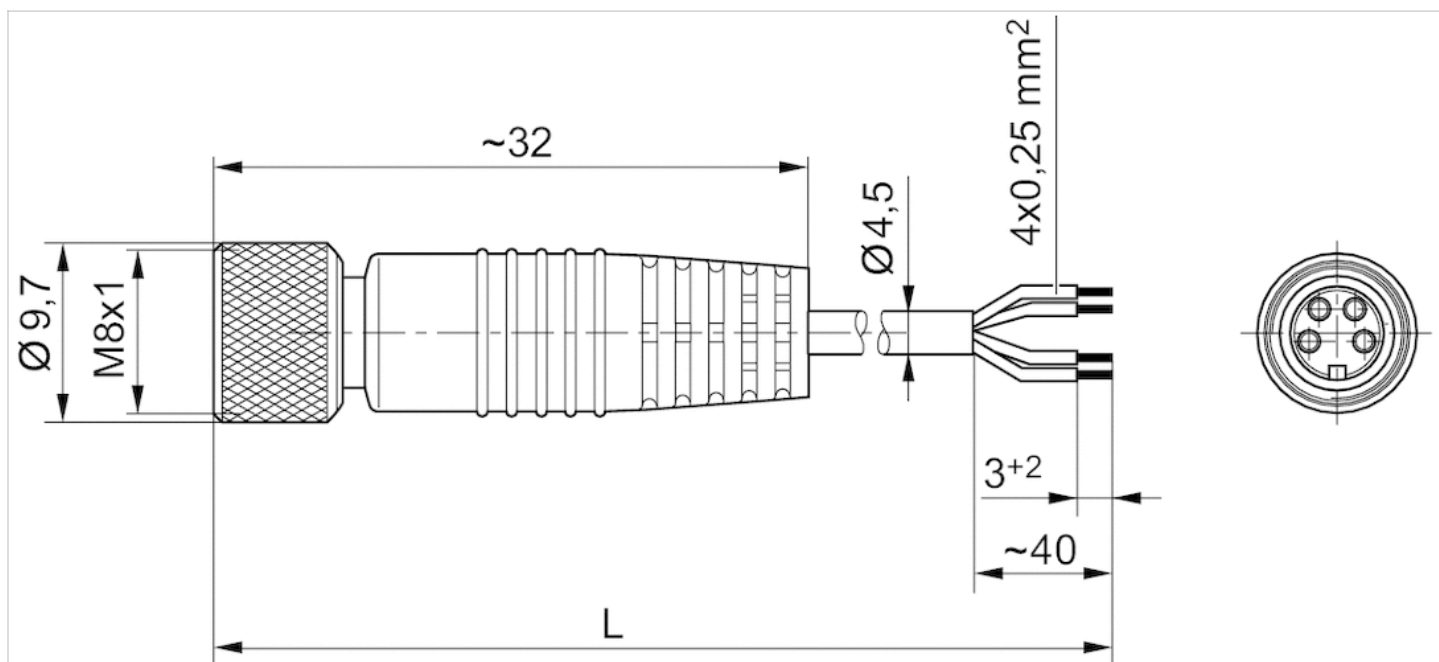

L = length

Pin assignments

Pin assignment, socket

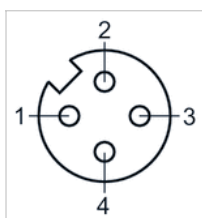

- (1) BN=brown
- (2) WH=white
- (3) BU=blue
- (4) BK=black

Round plug connector, Series CON-RD

- Socket M8x1 4-pin A-coded angled 90°
- open cable ends
- with cable
- unshielded



Ambient temperature min./max.	-25 ... 85 °C
Operational voltage	48 V AC/DC
Protection class	IP67
Wire cross-section	0.25 mm ²
Weight	See table below

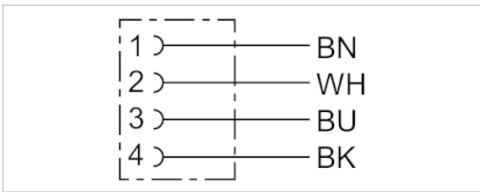

Technical data

Part No.	Max. current	Number of wires	Cable-Ø	Cable length	Weight
1834484145	4 A	4	4.5 mm	3 m	0.086 kg
1834484147	4 A	4	4.5 mm	5 m	0.141 kg

Technical information

The specified protection class is only valid in assembled and tested state.

Technical information

Material	
Housing	Polyurethane
Cable sheath	Polyurethane

Dimensions

Dimensions

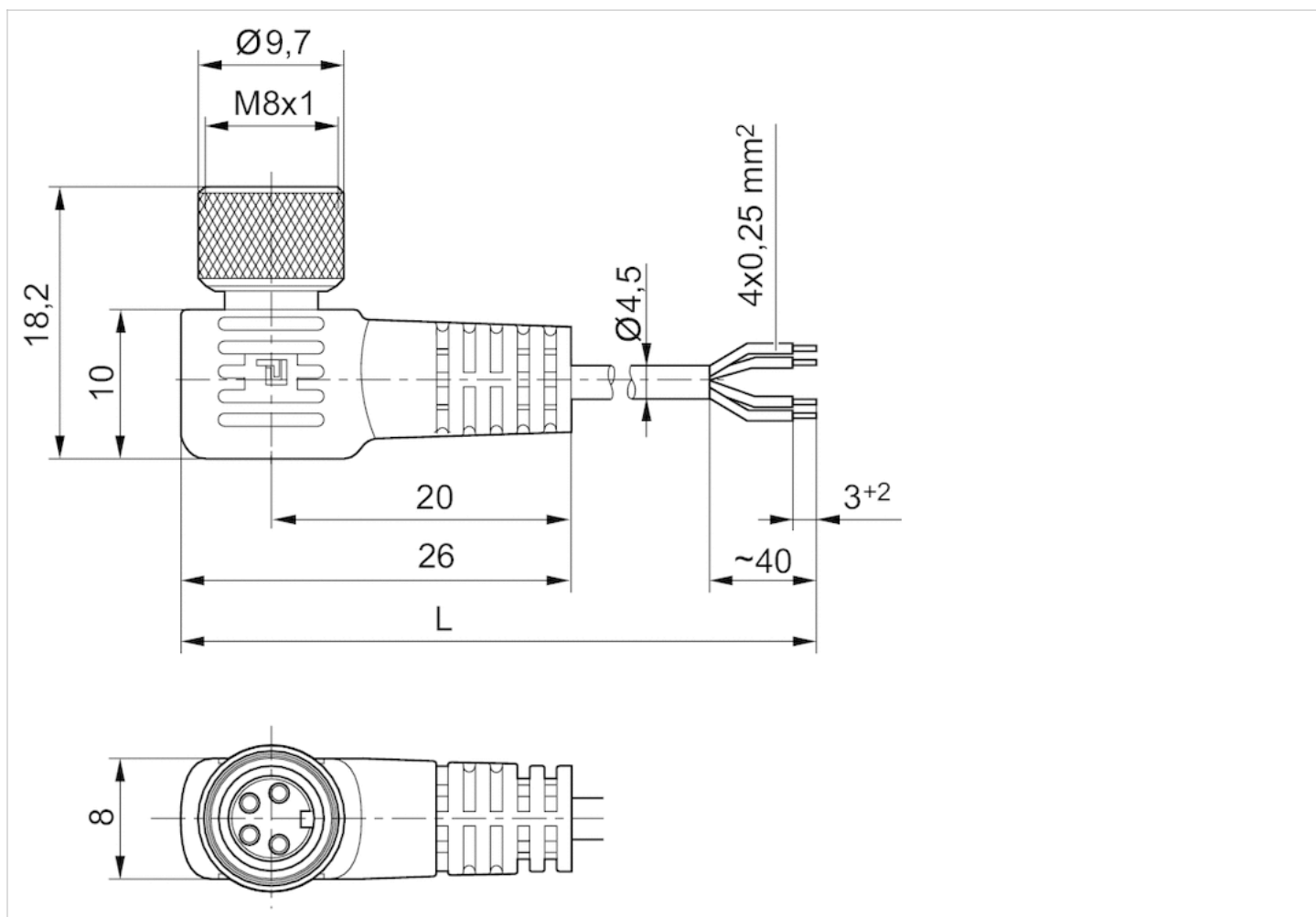

L = length

Pin assignments

Pin assignment, socket

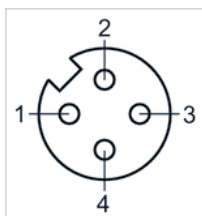

- (1) BN=brown
- (2) WH=white
- (3) BU=blue
- (4) BK=black

Silencers, series SI1

- G 1/8
- Sintered bronze



Working pressure min./max.	0 ... 10 bar
Ambient temperature min./max.	-25 ... 80 °C
Medium	Compressed air
Sound pressure level	75 dB
Weight	0.01 kg
Comment	Flow characteristic curves can be found under "Diagrams".

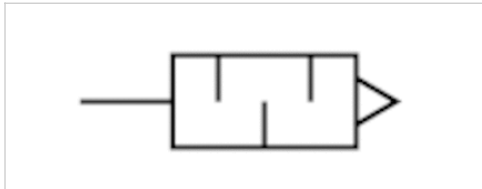

Technical data

Part No.	Compressed air connection	Flow	Delivery unit
		Qn	
1827000000	G 1/8	1623 l/min	10 piece

Weight per piece

Nominal flow Qn at p1 = 6 bar (absolute) freely discharged. Sound pressure level measured at 6 bar against atmosphere at 1 m distance.

Technical information

Material	
Silencer	Sintered bronze
Thread	Brass

Dimensions

Dimensions in mm

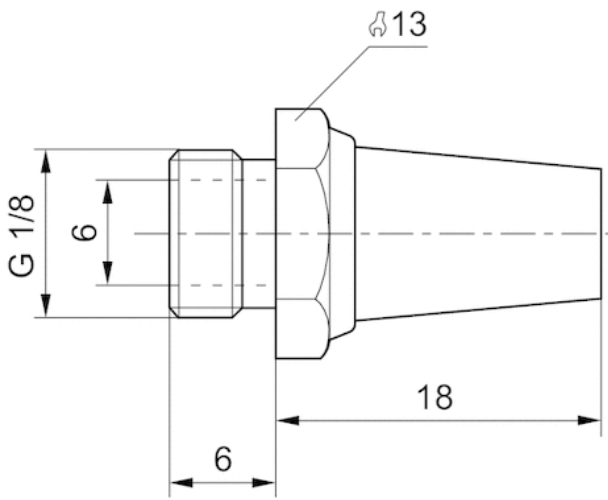

Diagrams

Flow diagram, 1827000000

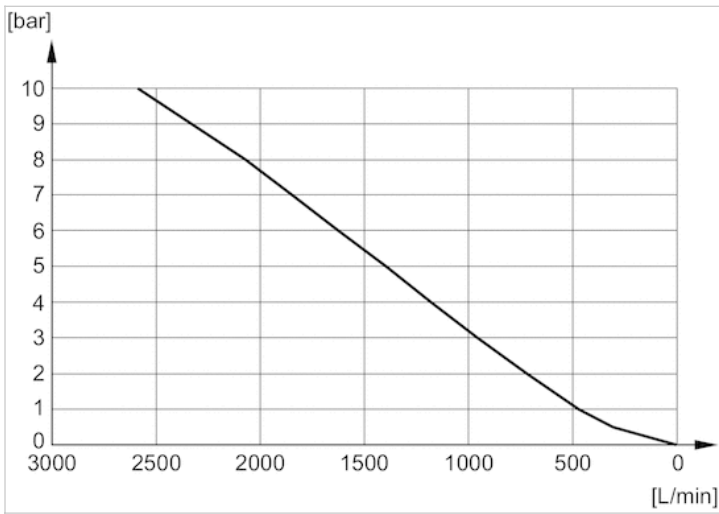

Silencers, series SI1

- G 1/2
- Sintered bronze



Working pressure min./max.	0 ... 10 bar
Ambient temperature min./max.	-25 ... 80 °C
Medium	Compressed air
Sound pressure level	90 dB
Weight	0.08 kg
Comment	Flow characteristic curves can be found under "Diagrams".

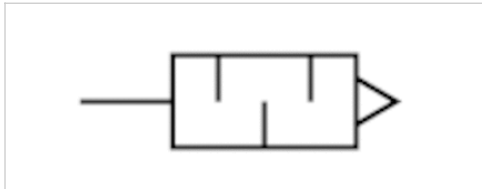

Technical data

Part No.	Compressed air connection	Flow	Delivery unit
		Qn	
1827000003	G 1/2	7223 l/min	2 piece

Weight per piece

Nominal flow Qn at p1 = 6 bar (absolute) freely discharged. Sound pressure level measured at 6 bar against atmosphere at 1 m distance.

Technical information

Material	
Silencer	Sintered bronze
Thread	Brass

Dimensions

Dimensions in mm

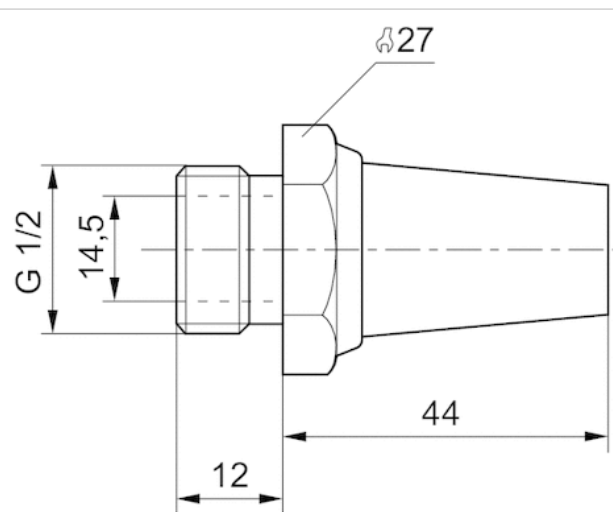

Diagrams

Flow diagram, 1827000003

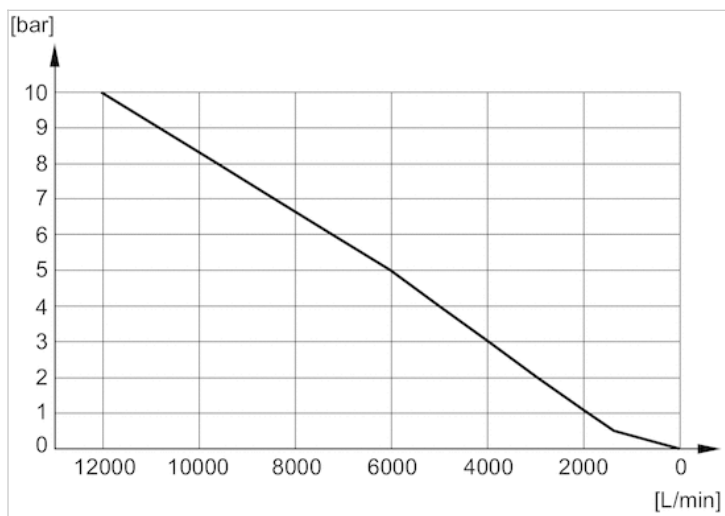

Mounting kit for DIN rails DIN

- standard 26 mm

- type A



Weight

0.014 kg

Technical data

Part No.	Type	Accessory type	Frame size	Delivery unit
1821398007	Mounting kit for DIN rails EN 60715, 35x15	type A	26 mm	1 piece

Dimensions

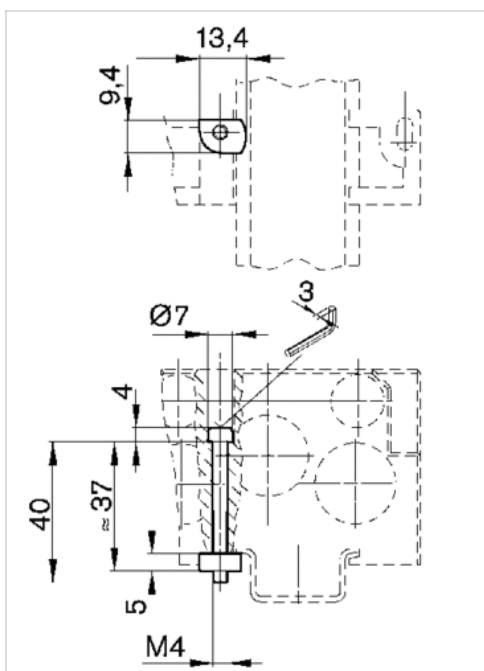

Accessories, Series TC15



Weight

See table below

Technical data

Part No.	Type	L = length
1825504357	end plate kit: internal pilot, pneumatic subbase, right	-
R422101300	End plate kit: internal pilot, right pneumatic subbase, connection thread NPTF	-
1825504358	end plate kit: external pilot, pneumatic subbase, right	-
R422101301	End plate kit: external pilot, right pneumatic subbase, connection thread NPTF	-
R422000802	end plate kit: internal pilot, pneumatic subbase, left	-
R422000803	end plate kit: external pilot, pneumatic subbase, left	-
R422000678	end plate kit: internal pilot, pneumatic subbase on both sides	-
R422000679	end plate kit: external pilot, pneumatic subbase on both sides	-
1821039042	supply/separation plate, channels 1,3,5 closed, for subbase, right	-
R422101302	Supply/separation plate, channels 1, 3, 5 closed, for right subbase, connection thread NPTF	-
R412009789	supply/separation plate, channels 1,3,5 closed, for subbase, left	-
R422000726	supply/separation plate, channel 1 closed, channels 3 and 5 open, for subbase, right	-
R422101303	Supply/separation plate, channel 1 closed, channels 3 and 5 open, for right subbase, connection thread NPTF	-
R422000502	Blanking plate	-
1823053258	Tie rod, 2x, 1 piece	67.6 mm
1823053259	Tie rod, 3x, 1 piece	88.5 mm
1823053260	Tie rod, 4x, 1 piece	109.4 mm
1823053261	Tie rod, 5x, 1 piece	130.3 mm
1823053262	Tie rod, 6x, 1 piece	151.2 mm
1823053263	Tie rod, 7x, 1 piece	172.1 mm
1823053264	Tie rod, 8x, 1 piece	193 mm
1823053265	Tie rod, 9x, 1 piece	213.9 mm
1823053266	Tie rod, 10x, 1 piece	234.8 mm
1823053267	Tie rod, 11x, 1 piece	255.7 mm
1823053268	Tie rod, 12x, 1 piece	276.6 mm
1823503999	Tie rod extension, 1 piece	-
R422000141	Sealing kit, 10 pieces	-

Part No.	Weight
1825504357	0.435 kg

Part No.	Weight
R422101300	0.435 kg
1825504358	0.429 kg
R422101301	0.429 kg
R422000802	0.485 kg
R422000803	0.434 kg
R422000678	0.75 kg
R422000679	0.935 kg
1821039042	0.245 kg
R422101302	0.245 kg
R412009789	0.245 kg
R422000726	0.244 kg
R422101303	0.244 kg
R422000502	0.265 kg
1823053258	0.012 kg
1823053259	0.017 kg
1823053260	0.021 kg
1823053261	0.026 kg
1823053262	0.031 kg
1823053263	0.036 kg
1823053264	0.04 kg
1823053265	0.046 kg
1823053266	0.05 kg
1823053267	0.055 kg
1823053268	0.068 kg
1823503999	0.004 kg
R422000141	0.04 kg

Technical information

3 tie rods are required per valve system.

Dimensions

Dimensions, Tie-rods

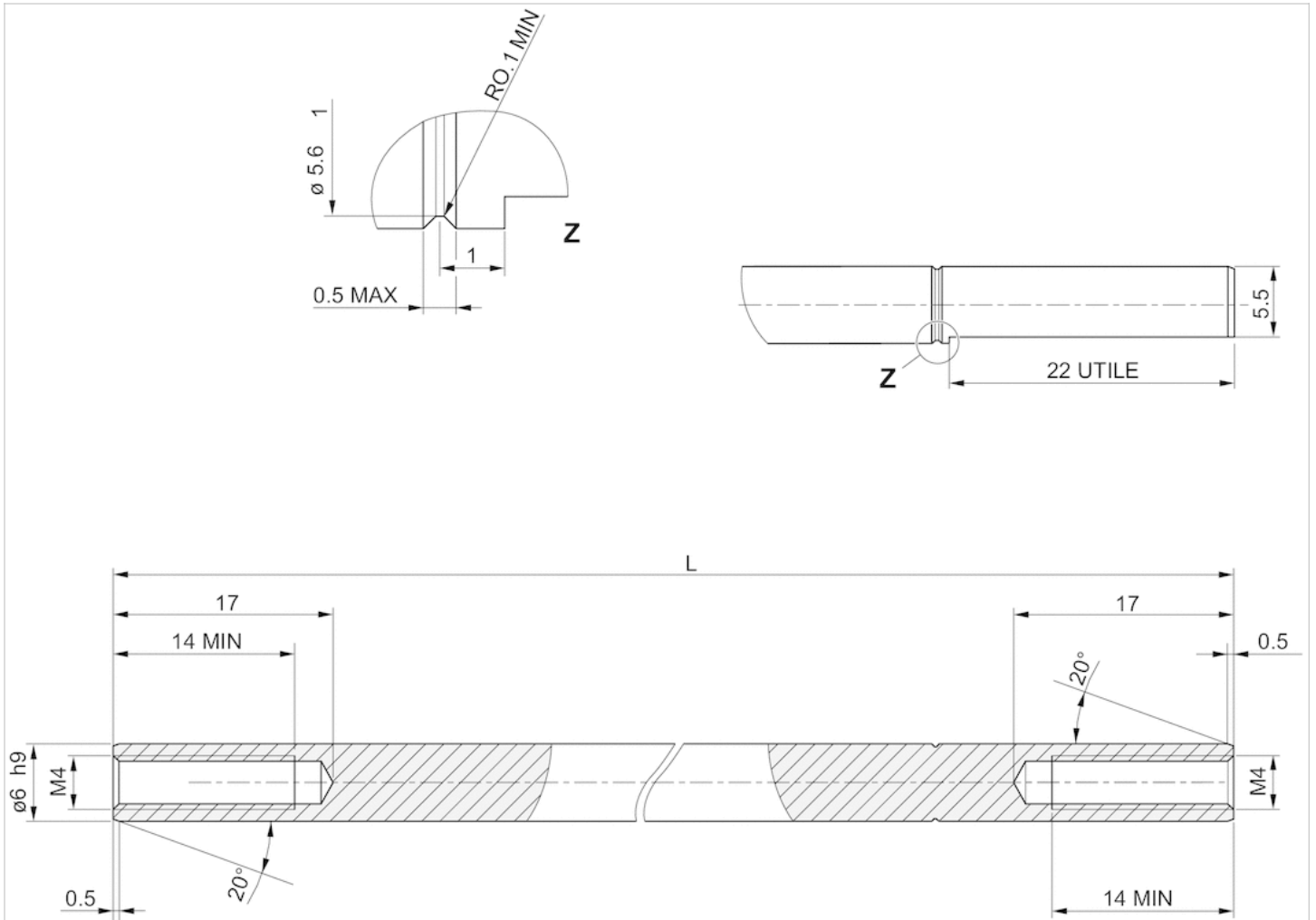

Efficient pneumatic solutions, our program: cylinders and drives, valves and valve systems, air supply management



Visit us: [Emerson.com/Aventics](https://www.emerson.com/Aventics)

Your local contact: [Emerson.com/contactus](https://www.emerson.com/contactus)



[Emerson.com](https://www.emerson.com)



[Facebook.com/EmersonAutomationSolutions](https://www.facebook.com/EmersonAutomationSolutions)



[LinkedIn.com/company/Emerson-Automation-Solutions](https://www.linkedin.com/company/Emerson-Automation-Solutions)



[Twitter.com/EMR_Automation](https://twitter.com/EMR_Automation)

An example configuration is depicted on the title page. The delivered product may thus vary from that in the illustration. Subject to change. This Document, as well as the data, specifications and other information set forth in it, are the exclusive property of AVENTICS GmbH. It may not be reproduced or given to third parties without its consent. Only use the AVENTICS products shown in industrial applications. Read the product documentation completely and carefully before using the product. Observe the applicable regulations and laws of the respective country. When integrating the product into applications, note the system manufacturer's specifications for safe use of the product. The data specified only serve to describe the product. No statements concerning a certain condition or suitability for a certain application can be derived from our information. The information given does not release the user from the obligation of own judgment and verification. It must be remembered that the products are subject to a natural process of wear and aging.

The Emerson logo is a trademark and service mark of Emerson Electric Co. Brand logotype are registered trademarks of one of the Emerson family of companies. All other marks are the property of their respective owners. © 2017 Emerson Electric Co. All rights reserved.
2019-03



CONSIDER IT SOLVED™