

### GENERAL

**Detection**  
**Fluid**  
**Operating pressure**  
**Ambient temperature**

**Equipped for magnetic position detectors**  
Air or neutral gas, filtered, lubricated or not  
10 bar max.  
-20°C to +70°C

### CONSTRUCTION

**Body**  
**Piston rod**  
  
**Rod end**  
**Parti interne**  
**Piston seals**  
**Bearing**  
**Front, rear or side mounting**

Light alloy  
Stainless steel (Ø8 - 25 mm)  
Hard chrome plated steel (Ø32 - 100 mm)  
Tapped  
POM (polyacetal) or light alloy  
PUR (polyurethane)  
Autolubrificante  
With screws (not supplied)  
or flange (see mounting section)



[Configurator - CAD Files](#)

### 15-DIGIT PRODUCT CODE

**G 441 A - S K ---- A00**

**Thread connection**  
G = ISO 16030

**Product series**  
441

**Revision letter**  
A = Initial release

**Diameter (mm)**  
G = 8<sup>(2)</sup>      3 = 32  
H = 10<sup>(2)</sup>     4 = 40  
J = 12<sup>(2)</sup>     5 = 50  
K = 16<sup>(2)</sup>     6 = 63  
L = 20<sup>(2)</sup>     8 = 80  
M = 25<sup>(2)</sup>     1 = 100

<sup>(2)</sup> Available in stainless steel rod end only.

#### Rod options 1

**S** = Single rod, Double acting  
**1** = Single acting rod in  
**2** = Through rod, Double acting  
**4** = Rod antirotation device (Ø 20 a 100 mm)

#### Rod options 2

**K** = Hard chromed female thread rod end (Ø 32 a 100 mm)  
**G** = Stainless steel female thread rod end (Ø 8 a 100 mm)

#### Options

**A00** = Without  
**HTP** = High temperature (up to 120°C)<sup>(1)</sup>

<sup>(1)</sup> Non equipped for magnetic position detectors

#### Recommended standard strokes (mm)<sup>(3)</sup>

Ø mm	con-nect. Ø											max. stroke	Rod antirotation device max. stroke			
		4	5	10	15	20	25	30	40	50	60			80	100	
8	M5	S	SD	SD	D	D	D								30	-
10		S	SD	SD	D	D	D								30	-
12		S	SD	SD	D	D	D	D							40	-
16		S	SD	SD	SD	SD	SD	D	D						40	-
20		S	SD	SD	SD	SD	SD	D	D	D					60	60
25		SD	SD	SD	SD	SD	D	D	D					60	60	
32	G1/8		SD	SD	SD	SD	SD	D	D	D	D	D		100	100	
40			SD	SD	SD	SD	SD	D	D	D	D	D	D	120	100	
50			SD	SD	SD	SD	SD	D	D	D	D	D	D	150	100	
63			SD	SD	SD	SD	SD	D	D	D	D	D	D	150	100	
80			SD	SD	SD	SD	SD	D	D	D	D	D	D	150	100	
100			SD	SD	SD	SD	SD	D	D	D	D	D	D	150	100	

Strokes range available up to "max. stroke" column on the right.  
Please note strokes marked in grey exceed the maximum recommended.

<sup>(3)</sup> Other strokes on request. / Min. stroke: 4 mm

S = Single acting

D = Double acting only / SD = Single & Double acting

### POSITION DETECTORS

**Magnetic position detectors must be ordered separately:**

"C" model, magneto-resistive type, 2 or 3 wires, modèles "T", reed switch or magneto-resistive type  
"T" slots are available on Ø32-40-50-63-80-100]

### INSTALLATION

- For a longer lifetime, it is recommended to use external stoppers

All leaflets are available on: [www.asco.com](http://www.asco.com)

**DIMENSIONS (mm)**

[Configurator - CAD Files](#)

Ø 8 to 25 mm - single and double acting

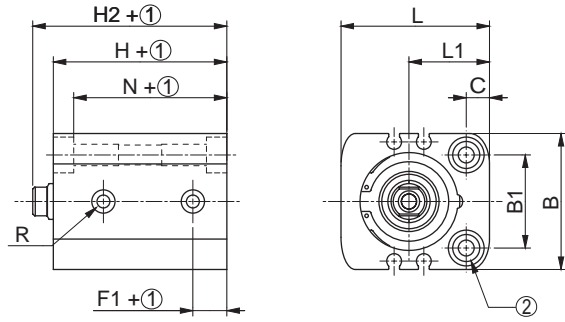

- ① Stroke
- ② Mounting holes and counterbores (see detailed view below and following pages)
- ③ Width across flats

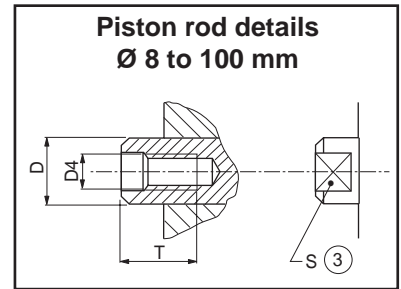

NOTE: In the single-acting version, the connection takes place on the port located in F.

Ø 32 to 100 mm - single acting

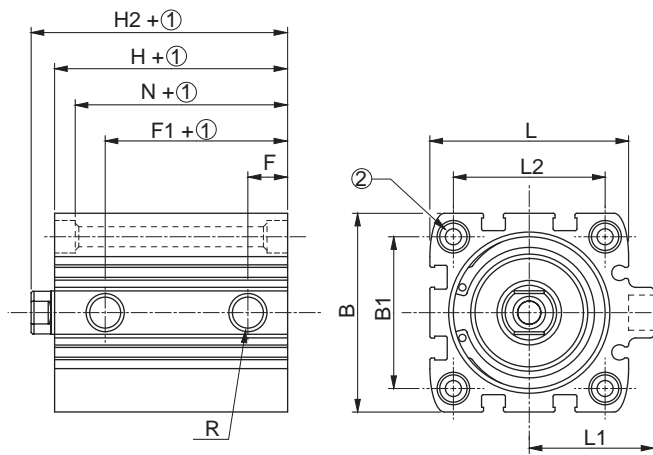

Ø 32 to 100 mm - double acting

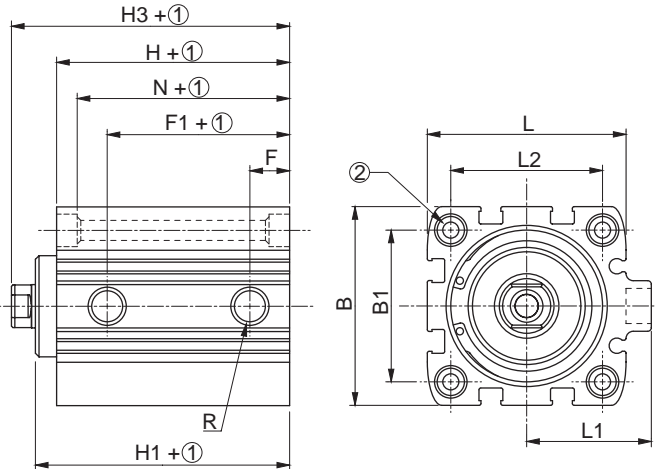

Ø	B	B <sub>1</sub>	C	Ø D	Ø D <sub>1</sub>	Ø D <sub>2</sub>	Ø D <sub>3</sub>	Ø D <sub>4</sub>	Ø D <sub>5</sub>	E <sub>1</sub>	E <sub>2</sub>	E <sub>3</sub>	F	F <sub>1</sub>	H	H <sub>1</sub>	H <sub>2</sub>	H <sub>3</sub>	L	L <sub>1</sub>	L <sub>2</sub>	N	Ø R	S	T
8	20	11	4,5	4	3,4	6	M4	M2,5	-	12	3,4	8,6	5	14	23	-	24	-	24	15	-	19,6	M5	-	3,5
10	21	12	4,5	4	3,4	6	M4	M2,5	-	12	3,4	8,6	5	15	24	-	25	-	25,5	15	-	20,6	M5	-	3,5
12	23	13	4,5	4	3,4	6	M4	M2,5	-	12	3,4	8,6	5	16	24	-	25	-	27,5	16,5	-	20,6	M5	-	3,5
16	28	18	5,5	7,8	4,5	8	M5	M4	-	15	4,6	10,4	6	18	32	-	36,5	-	31,5	17,5	-	27,4	M5	6	8
20	32	20	6,5	9,8	5,5	10	M6	M5	-	18	5,7	12,3	8	20	32	-	36,5	-	37,5	21,5	-	26,3	M5	8	11
25	38	26	6,5	9,8	5,5	10	M6	M5	-	18	5,7	12,3	9,5	24,5	38,5	-	44	-	41,5	22,5	-	33,8	M5	8	11
32	45	32	-	11,8	5,5	10	M6	M6	26	18	5,7	12,3	9,5	22	39,5	44,5	45	50,5	48	31	36	33,8	G1/8	10	13
40	55	42	-	11,8	5,5	10	M6	M6	28	18	5,7	12,3	11	25,5	39,5	45,5	46	52	55	34,5	42	33,8	G1/8	10	13
50	65	50	-	15,8	6,6	11	M8	M8	34	20	6,8	13,2	11	25,5	39,5	45,5	47	53	65	41,5	50	32,7	G1/8	13	12
63	80	62	-	15,8	9	15	M10	M8	38,5	25	9	16	11	27,3	42	50	48,5	57,5	80	49	62	33	G1/8	13	14
80	100	82	-	19,8	9	15	M10	M10	44	25	9	16	12,5	29,3	46	56	54	64	100	59	82	37	G1/8	17	16
100	124	103	-	24,6	11	18	M12	M12	56	30	11	19	12,5	36	56	66,5	66	76,5	124	71	103	45	G1/8	22	20

**Mounting holes**

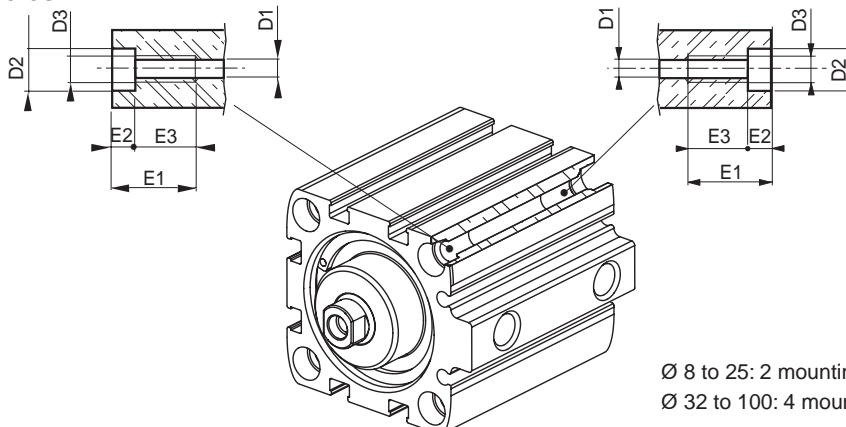

Ø 8 to 25: 2 mounting holes per face  
Ø 32 to 100: 4 mounting holes per face

**DIMENSIONS (mm)**

Ø 8 to 25 mm

[Configurator - CAD Files](#)

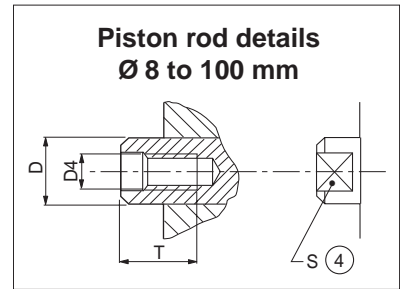
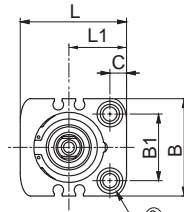
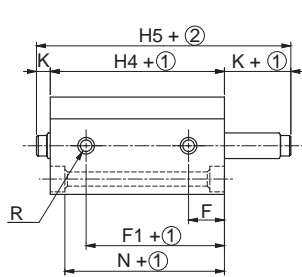

Ø 32 to 100 mm

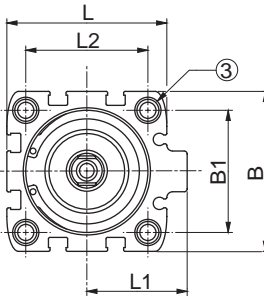
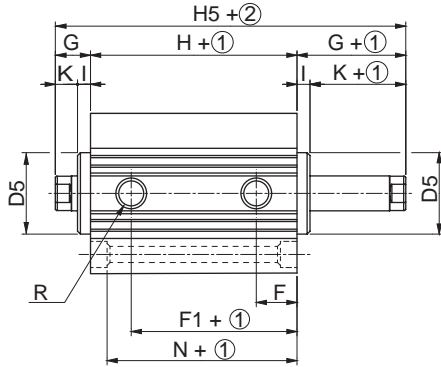

- ① Stroke
- ② Twice stroke  
For non-standard strokes, add the value of the immediately higher standard stroke.
- ③ Mounting holes and counterbores (see detailed view on page 4 and following pages)
- ④ Width across flats

Ø	B	B <sub>1</sub>	C	Ø D	Ø D <sub>1</sub>	Ø D <sub>2</sub>	Ø D <sub>4</sub>	Ø D <sub>5</sub>	E <sub>1</sub>	E <sub>2</sub>	E <sub>3</sub>	F	F <sub>1</sub>	G	H	H <sub>4</sub>	H <sub>5</sub>	I	K	L	L <sub>1</sub>	L <sub>2</sub>	N	Ø R	S	T
8	20	11	4,5	4	3,4	6	M2,5	-	12	3,4	8,6	9	21,5	-	-	26,5	28,5	-	1	24	15	-	23,1	M5	-	3,5
10	21	12	4,5	4	3,4	6	M2,5	-	12	3,4	8,6	9	22,5	-	-	26,5	28,5	-	1	25,5	15	-	23,1	M5	-	3,5
12	23	13	4,5	4	3,4	6	M2,5	-	12	3,4	8,6	9	20	-	-	27,5	29,5	-	1	27,5	16,5	-	24	M5	-	3,5
16	28	18	5,5	7,8	4,5	8	M4	-	15	4,6	10,4	14	31	-	-	39,5	48,5	-	4,5	31,5	17,5	-	35	M5	6	8
20	32	20	6,5	9,8	5,5	10	M5	-	18	5,7	12,3	12	26	-	-	38	47	-	4,5	37,5	21,5	-	32,3	M5	8	11
25	38	26	6,5	9,8	5,5	10	M5	-	18	5,7	12,3	14	34	-	-	48	59	-	5,5	41,5	22,5	-	42,3	M5	8	11
32	45	32	-	11,8	5,5	10	M6	26	18	5,7	12,3	17,5	30	11	47,5	-	69,5	5	6	48	31	36	41,8	G1/8	10	13
40	55	42	-	11,8	5,5	10	M6	28	18	5,7	12,3	14	32	12,5	46	-	71	6	6,5	55	34,5	42	40,3	G1/8	10	13
50	65	50	-	15,8	6,6	11	M8	34	20	6,8	13,2	14	32,5	13,5	46,5	-	73,5	6	7,5	65	41,5	50	39,7	G1/8	13	12
63	80	62	-	15,8	9	15	M8	38,5	25	9	16	15	33	16	48	-	80	8	8	80	49	62	39	G1/8	13	14
80	100	82	-	19,8	9	15	M10	44	25	9	16	16,7	34,3	18	51	-	87	10	8	100	59	82	42	G1/8	17	16
100	124	103	-	24,6	11	18	M12	56	30	11	19	20	44	20,5	64	-	105	10,5	10	124	71	103	53	G1/8	22	20

DIMENSIONS (mm)

[Configurator - CAD Files](#)

■ Ø 20 - Ø 25 mm

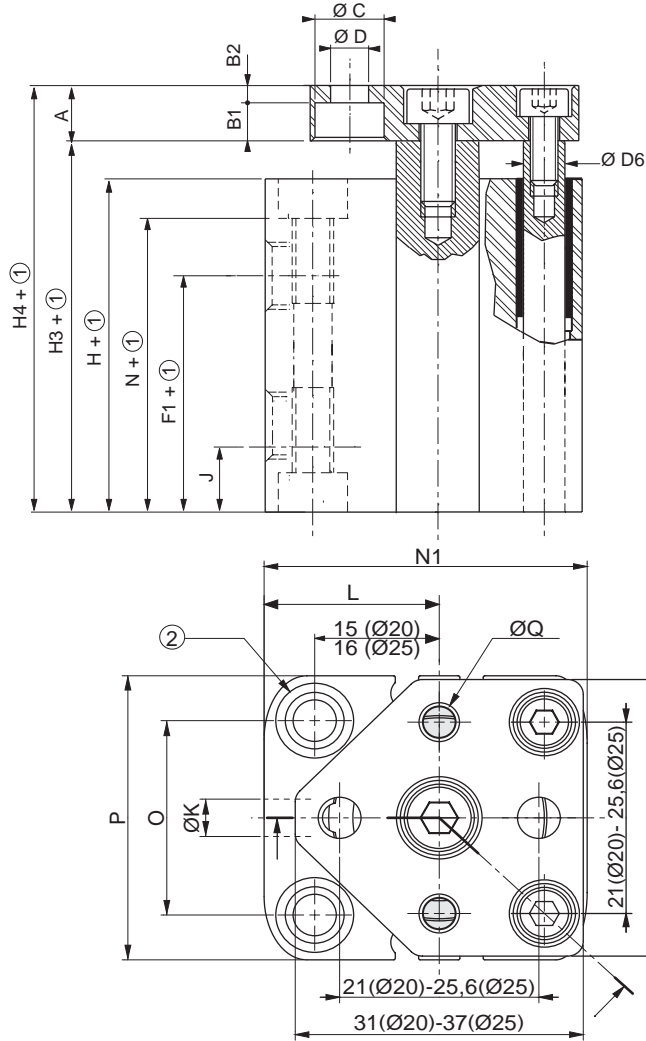

■ Ø 32 - Ø 100 mm

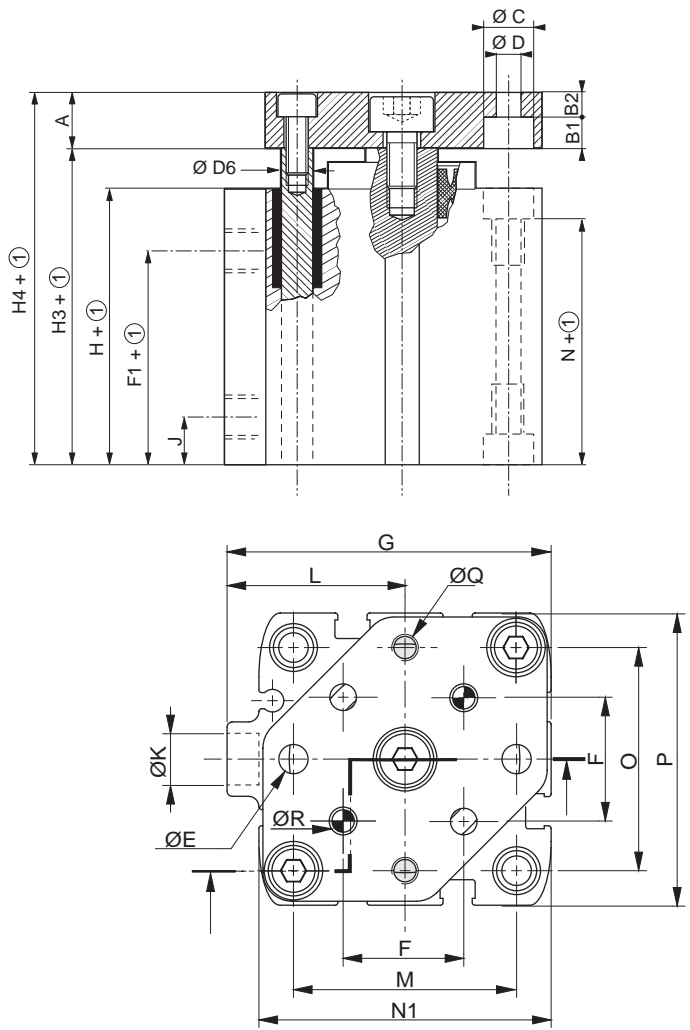

**Mounting holes**

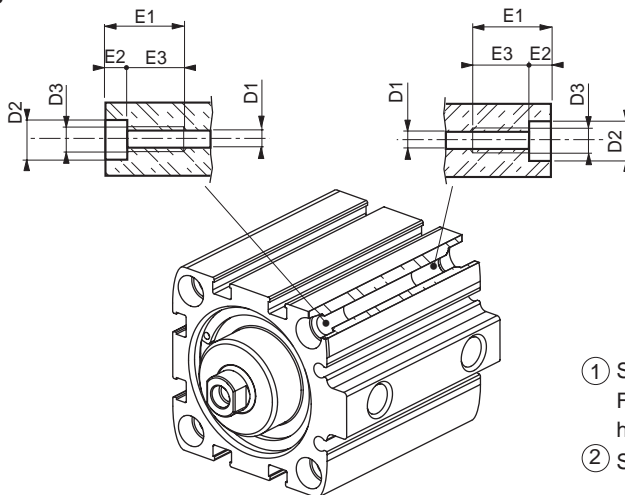

- ① Stroke  
For non-standard strokes, add the value of the immediately higher standard stroke.
- ② See detail for holes and counterbores

Ø	A	B1	B2	Ø C	Ø D	Ø D <sub>1</sub>	Ø D <sub>2</sub>	Ø D <sub>3</sub>	Ø D <sub>6</sub>	Ø E	E <sub>1</sub>	E <sub>2</sub>	E <sub>3</sub>	F	F <sub>1</sub>	G	H	H <sub>3</sub>	H <sub>4</sub>	J	Ø K	L	M	N	N <sub>1</sub>	O	P	Ø Q	Ø R
20	8	4,5	3,5	8	4,5	5,5	10	M6	5	-	18	5,7	12,3	-	20	-	32	36,5	44,5	8	M5	21,5	-	26,3	40	20	32	M3	-
25	8	5,5	2,5	10	5,5	5,5	10	M6	6	-	18	5,7	12,3	-	24,5	-	38,5	44	52	9,5	M5	21,5	-	32,8	44	26	38	M5	-
32	10	5,7	4,3	10	5,5	5,5	10	M6	8	-	18	5,7	12,3	-	22	56	39,5	50,5	60,5	9,5	G1/8	31	36	33,8	48	32	45	M5	-
40	10	5,7	4,3	10	5,5	5,5	10	M6	8	5,1	18	5,7	12,3	23,3	25,5	65	39,5	52	62	11	G1/8	34,5	42	33,8	55	42	55	M5	M5
50	12	5,7	6,3	10	5,5	6,6	11	M8	8	6,1	20	6,8	13,2	29,7	25,5	75	39,5	53	65	11	G1/8	41,5	50	32,7	65	50	65	M5	M6
63	12	6,8	5,2	11	6,6	9	15	M10	10	6,1	25	9	16	35,4	27,3	87,5	42	57,5	69,5	11	G1/8	49	62	33	80	62	80	M6	M6
80	14	6,8	7,2	11	6,6	9	15	M10	10	8,1	25	9	16	46	29,3	110	46	64	78	12,5	G1/8	59	82	37	100	82	100	M6	M8
100	16	9	7	15	9	11	18	M12	10	10,1	30	11	19	56,6	36	134	56	76,5	92,5	12,5	G1/8	71	103	45	124	103	124	M8	M10

All leaflets are available on: [www.asco.com](http://www.asco.com)

**DIMENSIONS (mm)** 

The tapped and counterbore holes provide great flexibility for mounting. The tappings simplify securing of cylinders, particularly when in long stroke.

• **Front mounting**

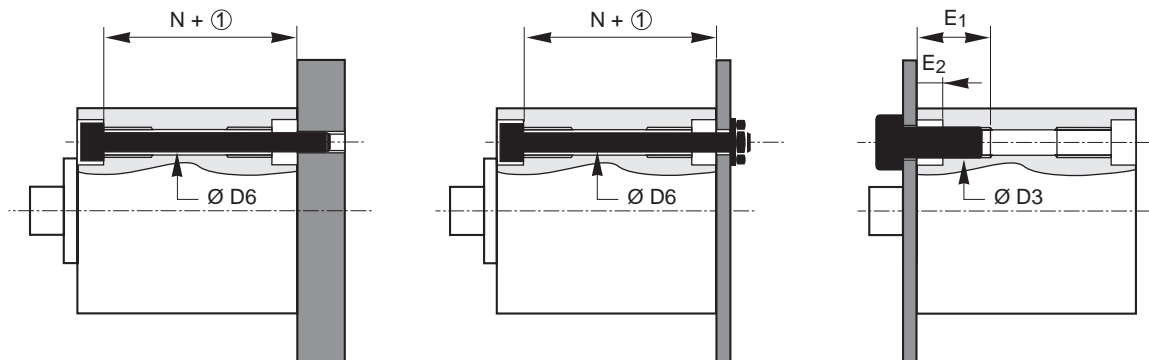

• **Rear mounting**

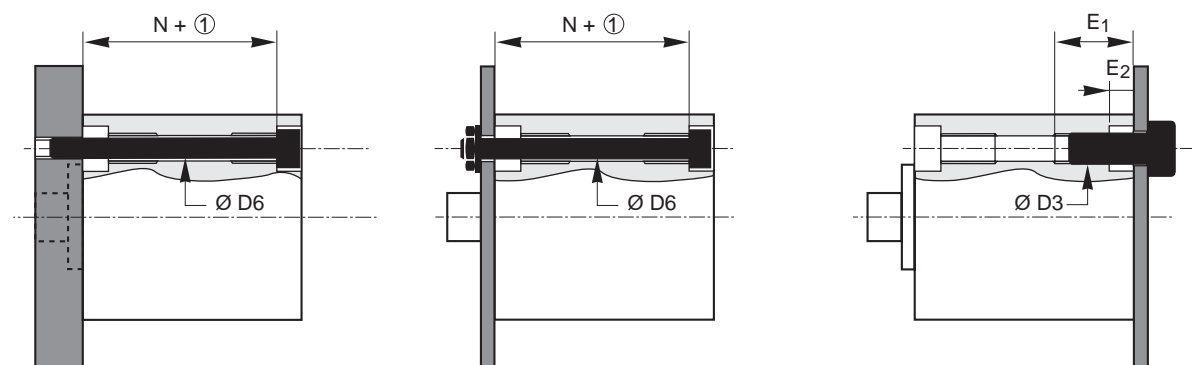

① Stroke  
For non-standard strokes, add the next higher standard one.

Ø	Ø D3	Ø D6	E <sub>1</sub>	E <sub>2</sub>	N
8	M4	M3	12	3,4	19,6
10	M4	M3	12	3,4	20,6
12	M4	M3	12	3,4	20,6
16	M5	M4	15	4,6	27,4
20	M6	M5	18	5,7	26,3
25	M6	M5	18	5,7	32,8
32	M6	M5	18	5,7	33,8
40	M6	M5	18	5,7	33,8
50	M8	M6	20	6,8	32,7
63	M10	M8	25	9	33
80	M10	M8	25	9	37
100	M12	M10	30	11	45

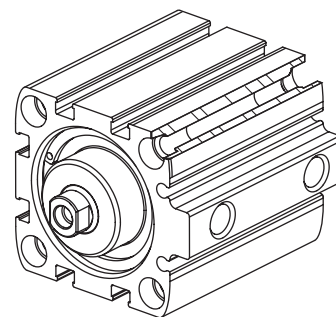

Ø 8 to 25 : 2 mounting holes per face  
Ø 32 to 100 : 4 mounting holes per face

**DIMENSIONS (mm), WEIGHT (kg)**

A set of two flanges enables front, rear or side mounting of cylinders with bores of 32 to 100 mm, for single-acting, or double-acting, single rod or double crossbar type. (The set comprises two flanges and four screws for securing them to the cylinder).

Ø (mm)	catalogue number set of two flanges
32	P493A302E100A00
40	P493A402E100A00
50	P493A502E100A00
63	P493A602E100A00
80	P493A802E100A00
100	P493A102E100A00

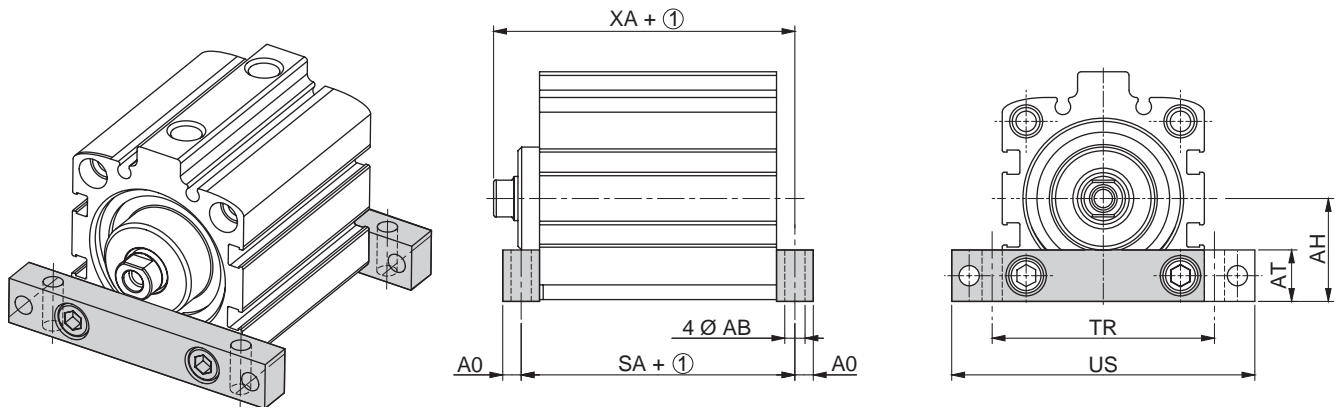
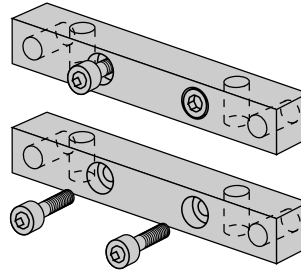

• **Front or rear mounting**

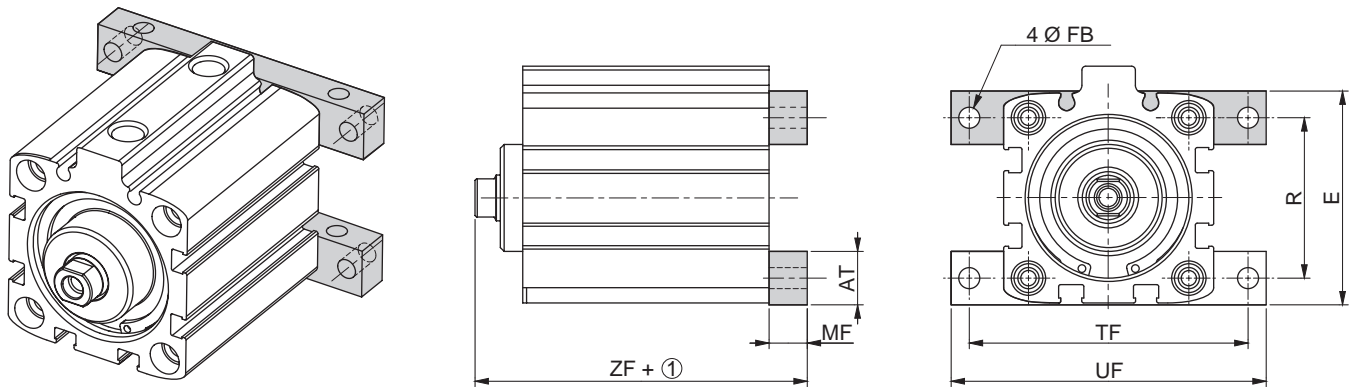

① Stroke  
For non-standard strokes, add the next higher standard one.

Ø (mm)	Ø AB	AH	AO	AT	E	Ø FB	MF	R	TF	TR	UF US	SA		XA		ZF		flanges weight
												(2)	(3)	(2)	(3)	(2)	(3)	
32	5,5	25	5	14	50	5,5	10	36	63	50,5	72,5	49,5	57,5	55,5	63,5	60,5	68,5	0,065
40	5,5	28	5	14	56	5,5	10	42	73	60,5	82,5	49,5	56	57	63,5	62	68,5	0,080
50	6,6	33	6	16	66	6,6	12	50	88	72,5	99	51,5	58,5	59	66	65	72	0,135
63	9	41	7,5	20	82	9	15	62	111	91	125	57	63	65	71	72,5	78,5	0,250
80	9	51	7,5	20	102	9	15	82	116	53	131	61	66	71,5	76,5	79	84	0,260
100	10,5	62,5	8,5	22	125	10,5	17	103	142,5	64,5	160	73	81	85	93	93,5	101,5	0,400

(2) Dimensions for single rod cylinder

(3) Dimensions for double crossbar cylinder

• Dimensions of bare cylinder, see specific overall dimensions pages.

• 32 mm bore cylinders are installed with the supply ports on top face.

The bodies of 40 to 100 mm bore cylinders can be rotated by 90° increments.

• For side-mounted Ø80-100 mm cylinders, distance between TR centres is less than the distance between the centres of the mounting holes.

## DIMENSIONS (mm), WEIGHT (kg)

### Threaded end piece

Threaded rod endfitting for the tapped rod end of standard 16 to 100 mm bore cylinders.

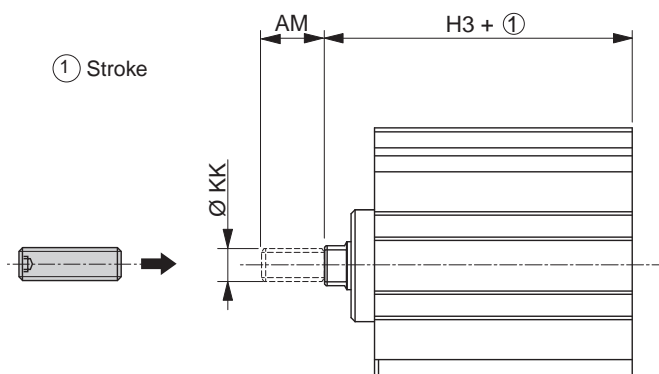

Ø (mm)	catalogue number threaded end piece	AM	H3 +	Ø KK
16	P493AK135000A00	8	36,5	M4
20	P493AL135000A00	12	36,5	M6
25		12	44	M6
32	P493A3135000A00	12	50,5	M6
40		12	52	M6
50	P493A5135000A00	15	53	M8
63		15	57,5	M8
80	P493A8135000A00	19	64	M10
100	P493A1135000A00	20	76,5	M12

In your order, indicate the code of the end piece, which is supplied separately.

### Female rod clevis

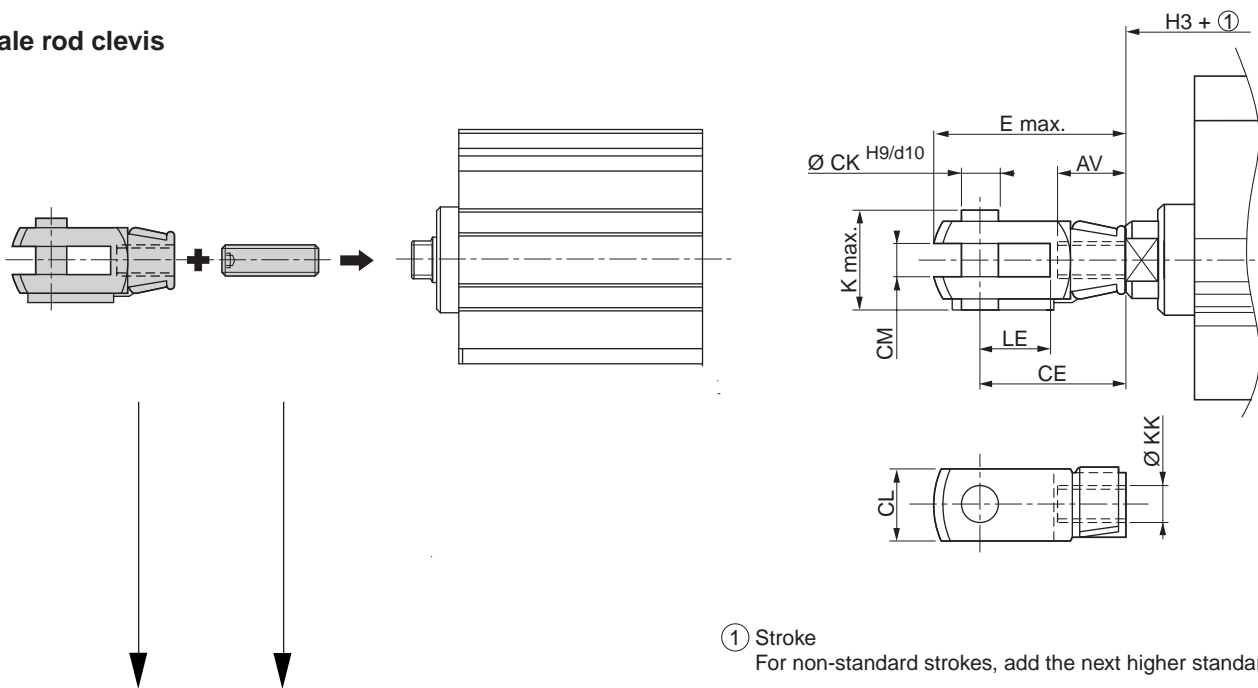

① Stroke  
For non-standard strokes, add the next higher standard one.

Ø (mm)	catalogue number female end piece	catalogue number threaded end piece	AV	CE	Ø CK	CL	CM	E	K	Ø KK	LE	H3	clevis weight
15	P493AG431000A00	P493AK135000A00	8	16	4	8	4 <sup>+0,4</sup> <sub>+0,1</sub>	22,5	11	M4	8	36,5	0,010
20	P493AJ431000A00	P493AL135000A00	12	24	6	12	6 <sup>+0,4</sup> <sub>+0,1</sub>	33,5	16,5	M6	12	36,5	0,020
25		44											
32		50,5											
40	P493A3135000A00										52		
50	P493AL431000A00	P493A5135000A00	16	32	8	16	6 <sup>+0,5</sup> <sub>+0,15</sub>	45	22	M8	16	53	0,050
63												57,5	
80	P493A3431000A00	P493A8135000A00	20	40	10	20	10 <sup>+0,5</sup> <sub>+0,15</sub>	56	26	M10	20	64	0,100
100	P493A4431000A00	P493A1135000A00	22	48	12	24	10 <sup>+0,5</sup> <sub>+0,15</sub>	67	32	M12	24	76,5	0,150

Please indicate the threaded and clevis end piece code in your order.



**SERIES 441  
SINGLE ACTING**

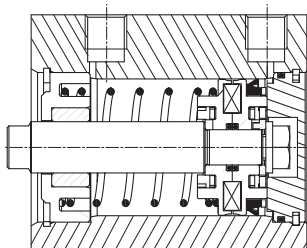

**SERIES 441  
DOUBLE ACTING**

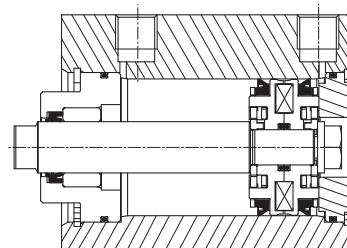

Ø (mm)	catalogue number
20	97801352
25	97801353
32	97801354
40	97801355
50	97801356
63	97801357
80	97801358
100	97801591
1 tube of grease, 11 cm <sup>3</sup>	97802100

The kits contain wearing parts. They are suitable for both single and double acting.