

Series CD07



AVENTICS™ Series CD07































3/2-directional valve, Series CD07

- 3/2
- Qn = 1400 l/min
- Pilot valve width : 30 mm
- NC/NO
- Pipe connection
- Compressed air connection output : G 1/4
- Electrical connection : Plug, EN 175301-803, form A, 3-pin
- -25 °C cold-resistant
- Manual override : with detent without
- single solenoid
- With spring return
- Pilot : Internal External



Version	Spool valve, positive overlapping
Activation	Electrically
Sealing principle	Soft sealing
Working pressure min./max.	See table below
Control pressure min./max.	3 ... 10 bar
Ambient temperature min./max.	See table below
Medium temperature min./max.	See table below
Medium	Compressed air
Max. particle size	50 µm
Oil content of compressed air	0 ... 1 mg/m ³
Nominal flow Qn	1400 l/min
Nominal flow 1 ► 2	1400 l/min
Nominal flow 2 ► 3	1400 l/min
Compressed air connection	according to ISO 228-1
Pilot control exhaust	with directional pilot air exhaust
Connector standard	EN 175301-803:2006
Reverse polarity protection	Protected against polarity reversal
Compatibility index	13 14
Duty cycle	100 %
Weight	See table below

Technical data

Part No.		MO		Compressed air connection	
					Input
5772070220			NC/NO		G 1/4
5772075270			NC/NO		G 1/4
5772075280			NC/NO		G 1/4
5772072220			NC/NO		G 1/4
5772075220			NC/NO		G 1/4
5772075302			NC/NO		G 1/4
5772080220			NC/NO		G 1/4
5772085270			NC/NO		G 1/4
5772085280			NC/NO		G 1/4
5772085220			NC/NO		G 1/4
5772085302			NC/NO		G 1/4
R412004091			NC/NO		G 1/4
R412004092			NC/NO		G 1/4
5772960220		—	NC/NO		G 1/4
5772965302		—	NC/NO		G 1/4

Part No.	Compressed air connection	
	Output	Exhaust
5772070220	G 1/4	G 1/4
5772075270	G 1/4	G 1/4
5772075280	G 1/4	G 1/4
5772072220	G 1/4	G 1/4
5772075220	G 1/4	G 1/4
5772075302	G 1/4	G 1/4
5772080220	G 1/4	G 1/4
5772085270	G 1/4	G 1/4
5772085280	G 1/4	G 1/4
5772085220	G 1/4	G 1/4
5772085302	G 1/4	G 1/4
R412004091	G 1/4	G 1/4
R412004092	G 1/4	G 1/4
5772960220	G 1/4	G 1/4
5772965302	G 1/4	G 1/4

Part No.	Compressed air connection	
	Pilot Input	Pilot Exhaust
5772070220	-	-
5772075270	-	-
5772075280	-	-
5772072220	-	-
5772075220	-	-
5772075302	-	-
5772080220	G 1/8	M5
5772085270	G 1/8	M5
5772085280	G 1/8	M5
5772085220	G 1/8	M5

Part No.	Compressed air connection	
	Pilot Input	Pilot Exhaust
5772085302	G 1/8	M5
R412004091	-	-
R412004092	G 1/8	M5
5772960220	-	-
5772965302	-	-

Part No.	Operational voltage		Operational voltage	
	DC	AC 50 Hz	AC 60 Hz	Operational voltage
5772070220	24 V	-	-	-
5772075270	-	110 V	110 V	110 V
5772075280	-	230 V	230 V	230 V
5772072220	24 V	-	-	-
5772075220	-	24 V	24 V	24 V
5772075302	-	-	-	-
5772080220	24 V	-	-	-
5772085270	-	110 V	110 V	110 V
5772085280	-	230 V	230 V	230 V
5772085220	-	24 V	24 V	24 V
5772085302	-	-	-	-
R412004091	24 V	-	-	-
R412004092	24 V	-	-	-
5772960220	24 V	-	-	-
5772965302	-	-	-	-

Part No.	Voltage tolerance		Voltage tolerance		Power consumption	
	DC	AC 50 Hz	AC 60 Hz	DC	DC	DC
5772070220	-10% / +10%	-	-	2.1 W	-	-
5772075270	-	-20% / +10%	-10% / +20%	-	-	-
5772075280	-	-20% / +10%	-10% / +20%	-	-	-
5772072220	-20% / +30%	-	-	4.5 W	-	-
5772075220	-	-20% / +10%	-10% / +20%	-	-	-
5772075302	-	-	-	-	-	-
5772080220	-10% / +10%	-	-	2.1 W	-	-
5772085270	-	-20% / +10%	-10% / +20%	-	-	-
5772085280	-	-20% / +10%	-10% / +20%	-	-	-
5772085220	-	-20% / +10%	-10% / +20%	-	-	-
5772085302	-	-	-	-	-	-
R412004091	-10% / +10%	-	-	2.1 W	-	-
R412004092	-10% / +10%	-	-	2.1 W	-	-
5772960220	-10% / +10%	-	-	2.1 W	-	-
5772965302	-	-	-	-	-	-

Part No.	Holding power		Switch-on power		Pilot
	AC 50 Hz	AC 60 Hz	AC 50 Hz	AC 60 Hz	
5772070220	-	-	-	-	Internal
5772075270	4.3 VA	3.3 VA	6.8 VA	5.7 VA	Internal
5772075280	4.8 VA	4.1 VA	6.9 VA	5.8 VA	Internal
5772072220	-	-	-	-	Internal

Part No.	Holding power	Holding power	Switch-on power	Switch-on power	Pilot
	AC 50 Hz	AC 60 Hz	AC 50 Hz	AC 60 Hz	
5772075220	4.3 VA	3.2 VA	6.9 VA	5.6 VA	Internal
5772075302	-	-	-	-	Internal
5772080220	-	-	-	-	External
5772085270	4.3 VA	3.3 VA	6.8 VA	5.7 VA	External
5772085280	4.8 VA	4.1 VA	6.9 VA	5.8 VA	External
5772085220	4.3 VA	3.2 VA	6.9 VA	5.6 VA	External
5772085302	-	-	-	-	External
R412004091	-	-	-	-	Internal
R412004092	-	-	-	-	External
5772960220	-	-	-	-	Internal
5772965302	-	-	-	-	Internal

Part No.	Working pressure min./max.	Ambient temperature min./max.	Medium temperature min./max.
5772070220	3 ... 10 bar	-25 ... 50 °C	-25 ... 50 °C
5772075270	3 ... 10 bar	-25 ... 50 °C	-25 ... 50 °C
5772075280	3 ... 10 bar	-25 ... 50 °C	-25 ... 50 °C
5772072220	3 ... 10 bar	-25 ... 50 °C	-25 ... 50 °C
5772075220	3 ... 10 bar	-25 ... 50 °C	-25 ... 50 °C
5772075302	3 ... 10 bar	-25 ... 50 °C	-25 ... 50 °C
5772080220	-0.95 ... 10 bar	-25 ... 50 °C	-25 ... 50 °C
5772085270	-0.95 ... 10 bar	-25 ... 50 °C	-25 ... 50 °C
5772085280	-0.95 ... 10 bar	-25 ... 50 °C	-25 ... 50 °C
5772085220	-0.95 ... 10 bar	-25 ... 50 °C	-25 ... 50 °C
5772085302	-0.95 ... 10 bar	-25 ... 50 °C	-25 ... 50 °C
R412004091	3 ... 10 bar	-10 ... 50 °C	-10 ... 50 °C
R412004092	-0.95 ... 10 bar	-10 ... 50 °C	-10 ... 50 °C
5772960220	3 ... 10 bar	-25 ... 50 °C	-25 ... 50 °C
5772965302	3 ... 10 bar	-25 ... 50 °C	-25 ... 50 °C

Part No.	Typ. switch-on time	Typ. switch-off time	Protection class	basic valve with electrical connector
			with connection	
5772070220	25 ms	45 ms	IP65	-
5772075270	25 ms	45 ms	IP65	-
5772075280	25 ms	45 ms	IP65	-
5772072220	25 ms	45 ms	IP65	-
5772075220	25 ms	45 ms	IP65	-
5772075302	-	-	-	Basic valve without coil
5772080220	25 ms	45 ms	IP65	-
5772085270	25 ms	45 ms	IP65	-
5772085280	25 ms	45 ms	IP65	-
5772085220	25 ms	45 ms	IP65	-
5772085302	-	-	-	Basic valve without coil
R412004091	25 ms	45 ms	IP65	-
R412004092	25 ms	45 ms	IP65	-
5772960220	25 ms	45 ms	IP65	-
5772965302	-	-	-	Basic valve without coil

Part No.	Power consumption	ATEX	Weight
5772070220	-	-	0.54 kg
5772075270	-	-	0.54 kg
5772075280	-	-	0.54 kg
5772072220	Higher voltage tolerance	-	0.54 kg
5772075220	-	-	0.54 kg
5772075302	-	ATEX optional	-
5772080220	-	-	0.54 kg
5772085270	-	-	0.54 kg
5772085280	-	-	0.54 kg
5772085220	-	-	0.54 kg
5772085302	-	ATEX optional	-
R412004091	-	ATEX	0.54 kg
R412004092	-	ATEX	0.54 kg
5772960220	-	-	0.54 kg
5772965302	-	-	-

Nominal flow Qn at 6 bar and $\Delta p = 1$ bar, MO = Manual override

Technical information

The min. control pressure must be adhered to, since otherwise faulty switching and valve failure may result!

The pressure dew point must be at least 15 °C under ambient and medium temperature and may not exceed 3 °C .

The oil content of compressed air must remain constant during the life cycle.

Use only the approved oils from AVENTICS. Further information can be found in the "Technical information" document (available in the MediaCentre).

ATEX optional: ATEX version can be produced by combining the basic valve without coil with an ATEX coil. ATEX ID: see ATEX coils catalog page.

option valve: The input and output compressed air connections can be exchanged.

The valve can thereby be used in the NC or NO operating mode.

Technical information

Material	
Housing	Die cast zinc Polyamide fiber-glass reinforced
Seals	Acrylonitrile butadiene rubber

Dimensions

Dimensions

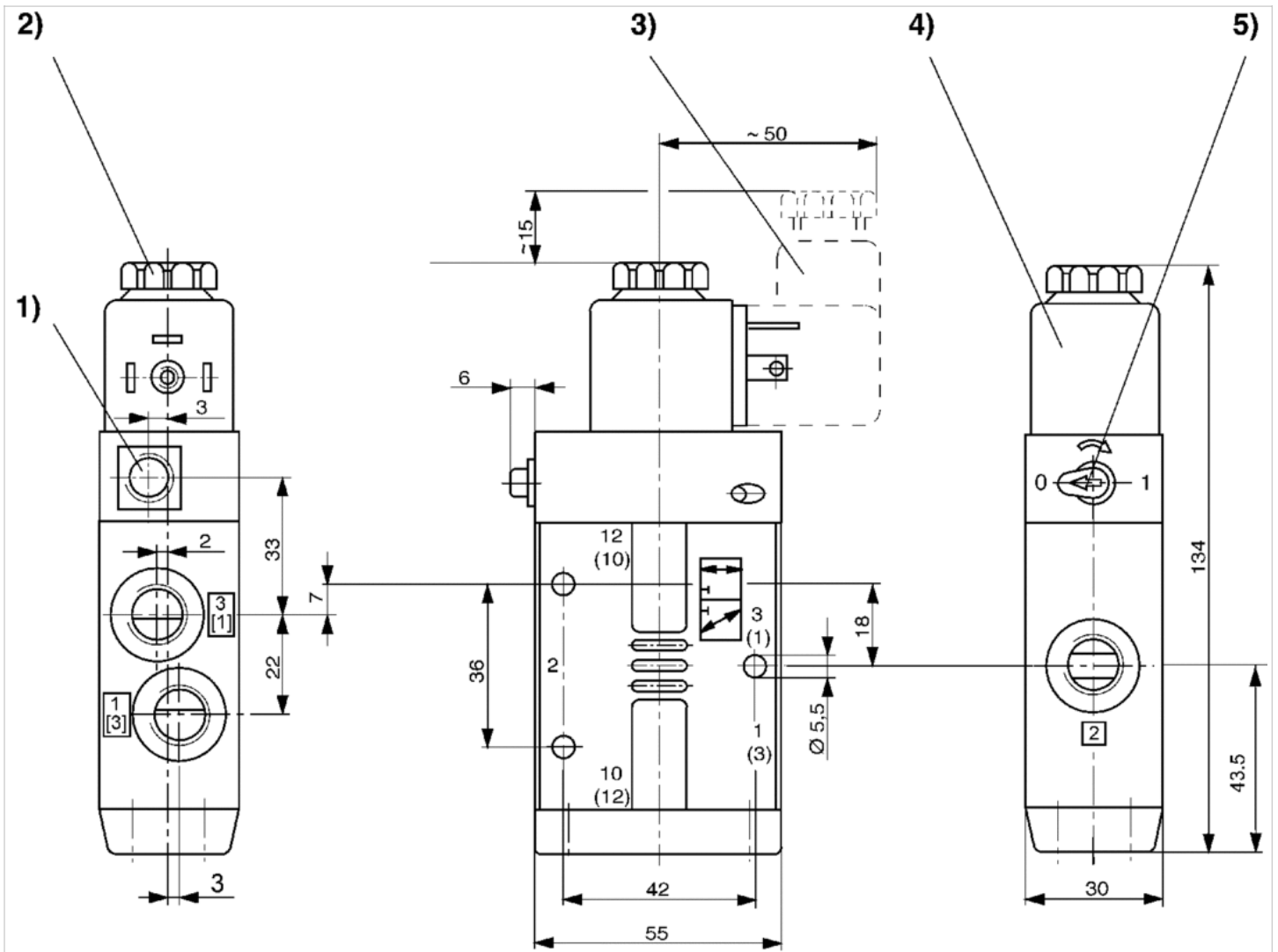

1) Only with separate pilot control G 1/8 2) After removal of cap M5 internal thread 3) Valve plug connector 4) Coil can be plugged at 45° intervals 5) Manual override

















3/2-directional valve, Series CD07

- 3/2
- Qn = 1400 l/min
- Pilot valve width : 30 mm
- NC/NO
- Pipe connection
- Compressed air connection output : M14x1,5
- Electrical connection : Plug, EN 175301-803, form A, 3-pin
- -25 °C cold-resistant
- Manual override : with detent
- single solenoid
- With spring return
- Pilot : Internal External



Version	Spool valve, positive overlapping
Activation	Electrically
Sealing principle	Soft sealing
Working pressure min./max.	See table below
Control pressure min./max.	3 ... 10 bar
Ambient temperature min./max.	-25 ... 50 °C
Medium temperature min./max.	-25 ... 50 °C
Medium	Compressed air
Max. particle size	50 µm
Oil content of compressed air	0 ... 1 mg/m ³
Nominal flow Qn	1400 l/min
Nominal flow 1 ► 2	1400 l/min
Nominal flow 2 ► 3	1400 l/min
Pilot control exhaust	with directional pilot air exhaust
Connector standard	EN 175301-803:2006
Reverse polarity protection	Protected against polarity reversal
Compatibility index	13 14
Duty cycle	100 %
Weight	See table below

Technical data

Part No.		MO		Compressed air connection	
				Input	
5772020220			NC/NO		M14x1,5
5772025270			NC/NO		M14x1,5
5772025280			NC/NO		M14x1,5
5772020770			NC/NO		M14x1,5
5772025302			NC/NO		M14x1,5
5772030220			NC/NO		M14x1,5
5772035280			NC/NO		M14x1,5
5772035302			NC/NO		M14x1,5

Part No.	Compressed air connection	
	Output	Exhaust
5772020220	M14x1,5	M14x1,5
5772025270	M14x1,5	M14x1,5
5772025280	M14x1,5	M14x1,5
5772020770	M14x1,5	M14x1,5
5772025302	M14x1,5	M14x1,5
5772030220	M14x1,5	M14x1,5
5772035280	M14x1,5	M14x1,5
5772035302	M14x1,5	M14x1,5

Part No.	Compressed air connection	
	Pilot Input	Pilot Exhaust
5772020220	-	-
5772025270	-	-
5772025280	-	-
5772020770	-	-
5772025302	-	-
5772030220	G 1/8	M5
5772035280	G 1/8	M5
5772035302	G 1/8	M5

Part No.	Operational voltage		Operational voltage	
	DC	AC 50 Hz	AC 60 Hz	
5772020220	24 V	-	-	
5772025270	-	110 V	110 V	
5772025280	-	230 V	230 V	
5772020770	110 V	-	-	
5772025302	-	-	-	
5772030220	24 V	-	-	
5772035280	-	230 V	230 V	
5772035302	-	-	-	

Part No.	Voltage tolerance			Power consumption
	DC	AC 50 Hz	AC 60 Hz	DC
5772020220	-10% / +10%	-	-	2.1 W
5772025270	-	-20% / +10%	-10% / +20%	-

Part No.	Voltage tolerance	Voltage tolerance	Voltage tolerance	Power consumption
	DC	AC 50 Hz	AC 60 Hz	DC
5772025280	-	-20% / +10%	-10% / +20%	-
5772020770	-20% / +30%	-	-	4.1 W
5772025302	-	-	-	-
5772030220	-10% / +10%	-	-	2.1 W
5772035280	-	-20% / +10%	-10% / +20%	-
5772035302	-	-	-	-

Part No.	Holding power	Holding power	Switch-on power	Switch-on power	Pilot
	AC 50 Hz	AC 60 Hz	AC 50 Hz	AC 60 Hz	
5772020220	-	-	-	-	Internal
5772025270	4.3 VA	3.3 VA	6.8 VA	5.7 VA	Internal
5772025280	4.8 VA	4.1 VA	6.9 VA	5.8 VA	Internal
5772020770	-	-	-	-	Internal
5772025302	-	-	-	-	Internal
5772030220	-	-	-	-	External
5772035280	4.8 VA	4.1 VA	6.9 VA	5.8 VA	External
5772035302	-	-	-	-	External

Part No.	Working pressure min./max.	Typ. switch-on time	Typ. switch-off time	Protection class
				with connection
5772020220	3 ... 10 bar	25 ms	45 ms	IP65
5772025270	3 ... 10 bar	25 ms	45 ms	IP65
5772025280	3 ... 10 bar	25 ms	45 ms	IP65
5772020770	3 ... 10 bar	25 ms	45 ms	IP65
5772025302	3 ... 10 bar	-	-	-
5772030220	-0.95 ... 10 bar	25 ms	45 ms	IP65
5772035280	-0.95 ... 10 bar	25 ms	45 ms	IP65
5772035302	-0.95 ... 10 bar	-	-	-

Part No.	basic valve with electrical connector	ATEX	Weight
5772020220	-	-	0.54 kg
5772025270	-	-	0.54 kg
5772025280	-	-	0.54 kg
5772020770	-	-	0.54 kg
5772025302	Basic valve without coil	ATEX optional	-
5772030220	-	-	0.54 kg
5772035280	-	-	0.54 kg
5772035302	Basic valve without coil	ATEX optional	-

Nominal flow Q_n at 6 bar and Δp = 1 bar, MO = Manual override

Technical information

The min. control pressure must be adhered to, since otherwise faulty switching and valve failure may result!

The pressure dew point must be at least 15 °C under ambient and medium temperature and may not exceed 3 °C .

The oil content of compressed air must remain constant during the life cycle.

Use only the approved oils from AVENTICS. Further information can be found in the "Technical information" document (available in the MediaCentre).

ATEX optional: ATEX version can be produced by combining the basic valve without coil with an ATEX coil. ATEX ID: see ATEX coils catalog page.

option valve: The input and output compressed air connections can be exchanged.

The valve can thereby be used in the NC or NO operating mode.

Technical information

Housing	Die cast zinc Polyamide fiber-glass reinforced
---------	--

Dimensions

Dimensions

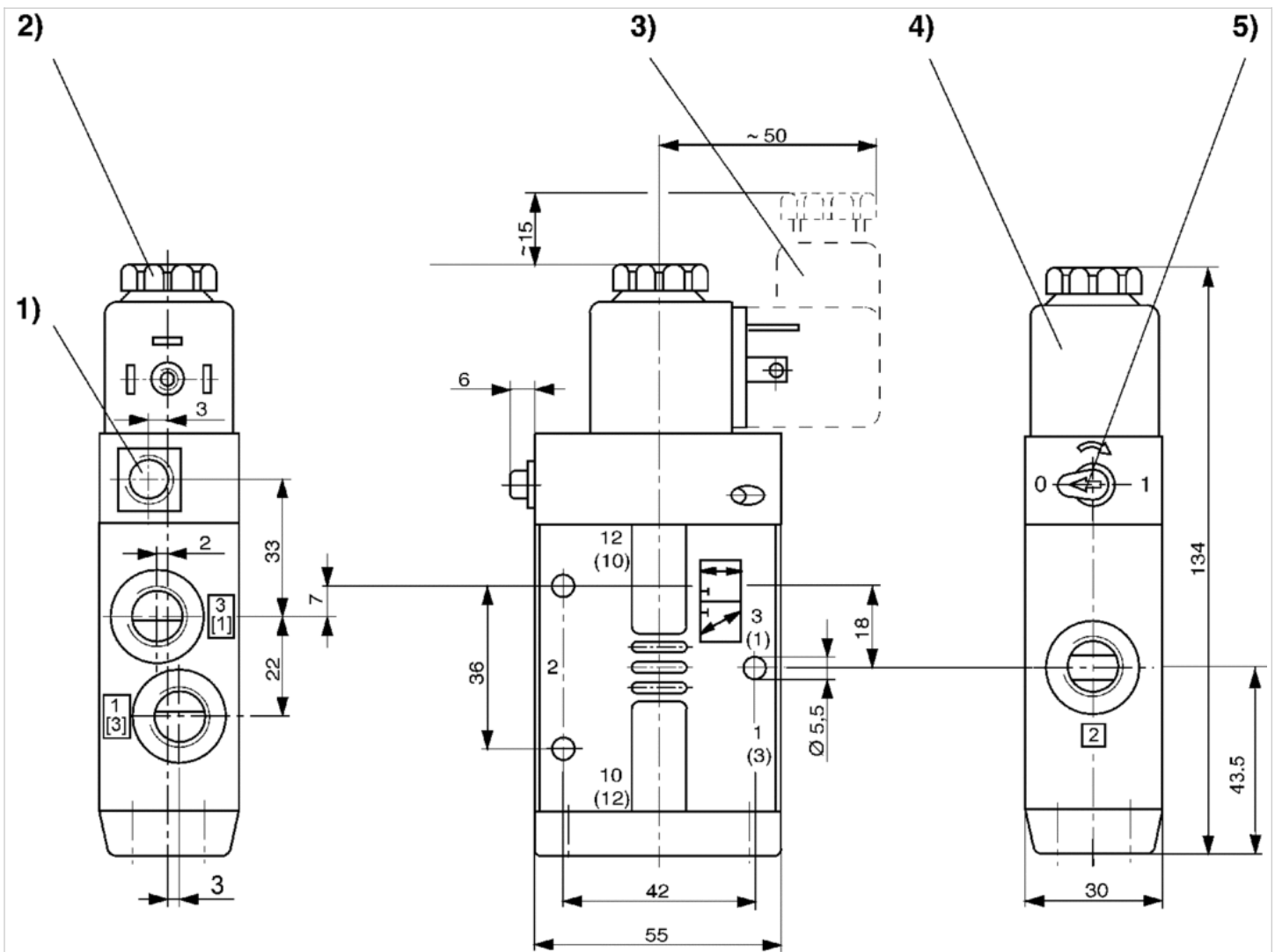

- 1) Only with separate pilot control G 1/8
- 2) After removal of cap M5 internal thread
- 3) Valve plug connector
- 4) Coil can be plugged at 45° intervals
- 5) Manual override





















5/2-directional valve, Series CD07

- 5/2
- Qn = 1200 l/min
- Pilot valve width : 30 mm
- Pipe connection
- Compressed air connection output : G 1/4
- Electrical connection : Plug, EN 175301-803, form A, 3-pin
- Manual override : with detent without
- single solenoid
- With spring return
- Pilot : Internal External



Version	Spool valve, positive overlapping
Activation	Electrically
Sealing principle	Soft sealing
Working pressure min./max.	See table below
Control pressure min./max.	3 ... 10 bar
Ambient temperature min./max.	See table below
Medium temperature min./max.	See table below
Medium	Compressed air
Max. particle size	50 µm
Oil content of compressed air	0 ... 1 mg/m ³
Nominal flow Qn	1200 l/min
Nominal flow 1 ► 2	1200 l/min
Nominal flow 2 ► 3	1200 l/min
Compressed air connection	according to ISO 228-1
Pilot control exhaust	with directional pilot air exhaust
Connector standard	EN 175301-803:2006
Reverse polarity protection	Protected against polarity reversal
Compatibility index	See table below
Duty cycle	100 %
Mounting on manifold strip	P-strip PRS strip
Weight	See table below

Technical data

Part No.		MO	Compressed air connection	
			Input	Output
5776070220			G 1/4	G 1/4
5776075280			G 1/4	G 1/4
5776080220			G 1/4	G 1/4
5776085280			G 1/4	G 1/4
5776075302			G 1/4	G 1/4
5776085302			G 1/4	G 1/4
R412004093			G 1/4	G 1/4
5776070360			G 1/4	G 1/4
5776085270			G 1/4	G 1/4
5776980220		—	G 1/4	G 1/4

Part No.	Compressed air connection	
	Exhaust	Pilot Input
5776070220	G 1/4	-
5776075280	G 1/4	-
5776080220	G 1/4	G 1/8
5776085280	G 1/4	G 1/8
5776075302	G 1/4	-
5776085302	G 1/4	G 1/8
R412004093	G 1/4	-
5776070360	G 1/4	-
5776085270	G 1/4	G 1/8
5776980220	G 1/4	-

Part No.	Compressed air connection		Operational voltage	
	Pilot Exhaust	DC	AC 50 Hz	AC 50 Hz
5776070220	-	24 V	-	-
5776075280	-	-	230 V	-
5776080220	M5	24 V	-	-
5776085280	M5	-	230 V	-
5776075302	-	-	-	-
5776085302	M5	-	-	-
R412004093	-	24 V	-	-
5776070360	-	96 V	-	-
5776085270	M5	-	110 V	-
5776980220	-	24 V	-	-

Part No.	Operational voltage	Voltage tolerance		
		DC	AC 50 Hz	AC 60 Hz
5776070220	-	-10% / +15%	-	-
5776075280	230 V	-	-20% / +10%	-10% / +20%
5776080220	-	-10% / +10%	-	-
5776085280	230 V	-	-20% / +10%	-10% / +20%
5776075302	-	-	-	-
5776085302	-	-	-	-

Part No.	Operational voltage	Voltage tolerance	Voltage tolerance	Voltage tolerance
		AC 60 Hz	DC	AC 50 Hz
R412004093	-	-10% / +10%	-	-
5776070360	-	-30% / +30%	-	-
5776085270	110 V	-	-20% / +10%	-10% / +20%
5776980220	-	-10% / +10%	-	-

Part No.	Power consumption	Holding power	Holding power	Switch-on power
	DC	AC 50 Hz	AC 60 Hz	AC 50 Hz
5776070220	2.1 W	-	-	-
5776075280	-	4.8 VA	4.1 VA	6.9 VA
5776080220	2.1 W	-	-	-
5776085280	-	4.8 VA	4.1 VA	6.9 VA
5776075302	-	-	-	-
5776085302	-	-	-	-
R412004093	2.1 W	-	-	-
5776070360	5.8 W	-	-	-
5776085270	-	4.3 VA	3.3 VA	6.8 VA
5776980220	2.1 W	-	-	-

Part No.	Switch-on power	Pilot	Working pressure min./max.	Ambient temperature min./max.
	AC 60 Hz			
5776070220	-	Internal	3 ... 10 bar	-25 ... 50 °C
5776075280	5.8 VA	Internal	3 ... 10 bar	-25 ... 50 °C
5776080220	-	External	-0.95 ... 10 bar	-25 ... 50 °C
5776085280	5.8 VA	External	-0.95 ... 10 bar	-25 ... 50 °C
5776075302	-	Internal	3 ... 10 bar	-25 ... 50 °C
5776085302	-	External	-0.95 ... 10 bar	-25 ... 50 °C
R412004093	-	Internal	3 ... 10 bar	-10 ... 50 °C
5776070360	-	Internal	3 ... 10 bar	-25 ... 50 °C
5776085270	5.7 VA	External	-0.95 ... 10 bar	-25 ... 50 °C
5776980220	-	Internal	3 ... 10 bar	-25 ... 50 °C

Part No.	Medium temperature min./max.	Typ. switch-on time	Typ. switch-off time	Compatibility index
5776070220	-25 ... 50 °C	25 ms	45 ms	13 14
5776075280	-25 ... 50 °C	25 ms	45 ms	13 14
5776080220	-25 ... 50 °C	25 ms	45 ms	13 14
5776085280	-25 ... 50 °C	25 ms	45 ms	13 14
5776075302	-25 ... 50 °C	-	-	13 14
5776085302	-25 ... 50 °C	-	-	13 14
R412004093	-10 ... 50 °C	25 ms	45 ms	13 14
5776070360	-25 ... 50 °C	25 ms	45 ms	14
5776085270	-25 ... 50 °C	25 ms	45 ms	14
5776980220	-25 ... 50 °C	25 ms	45 ms	14

Part No.	Protection class	basic valve with electrical connector	ATEX	Weight
	with connection			
5776070220	IP65	-	-	0.57 kg
5776075280	IP65	-	-	0.57 kg
5776080220	IP65	-	-	0.57 kg

Part No.	Protection class	basic valve with electrical connector	ATEX	Weight
	with connection			
5776085280	IP65	-	-	0.57 kg
5776075302	-	Basic valve without coil	ATEX optional	-
5776085302	-	Basic valve without coil	ATEX optional	-
R412004093	IP65	-	ATEX	0.57 kg
5776070360	IP65	-	-	0.57 kg
5776085270	IP65	-	-	0.57 kg
5776980220	IP65	-	-	0.57 kg

Nominal flow Q_n at 6 bar and $\Delta p = 1$ bar, MO = Manual override, Nickel-plated armature guide (only suitable for DC variant), i.e. the base must not be equipped with AC coils.

Technical information

The min. control pressure must be adhered to, since otherwise faulty switching and valve failure may result!
 The pressure dew point must be at least 15 °C under ambient and medium temperature and may not exceed 3 °C .
 The oil content of compressed air must remain constant during the life cycle.
 Use only the approved oils from AVENTICS. Further information can be found in the "Technical information" document (available in the MediaCentre).

ATEX optional: ATEX version can be produced by combining the basic valve without coil with an ATEX coil. ATEX ID: see ATEX coils catalog page.

Technical information

Material	
Housing	Die cast zinc Polyamide fiber-glass reinforced
Seals	Acrylonitrile butadiene rubber

Dimensions

Dimensions

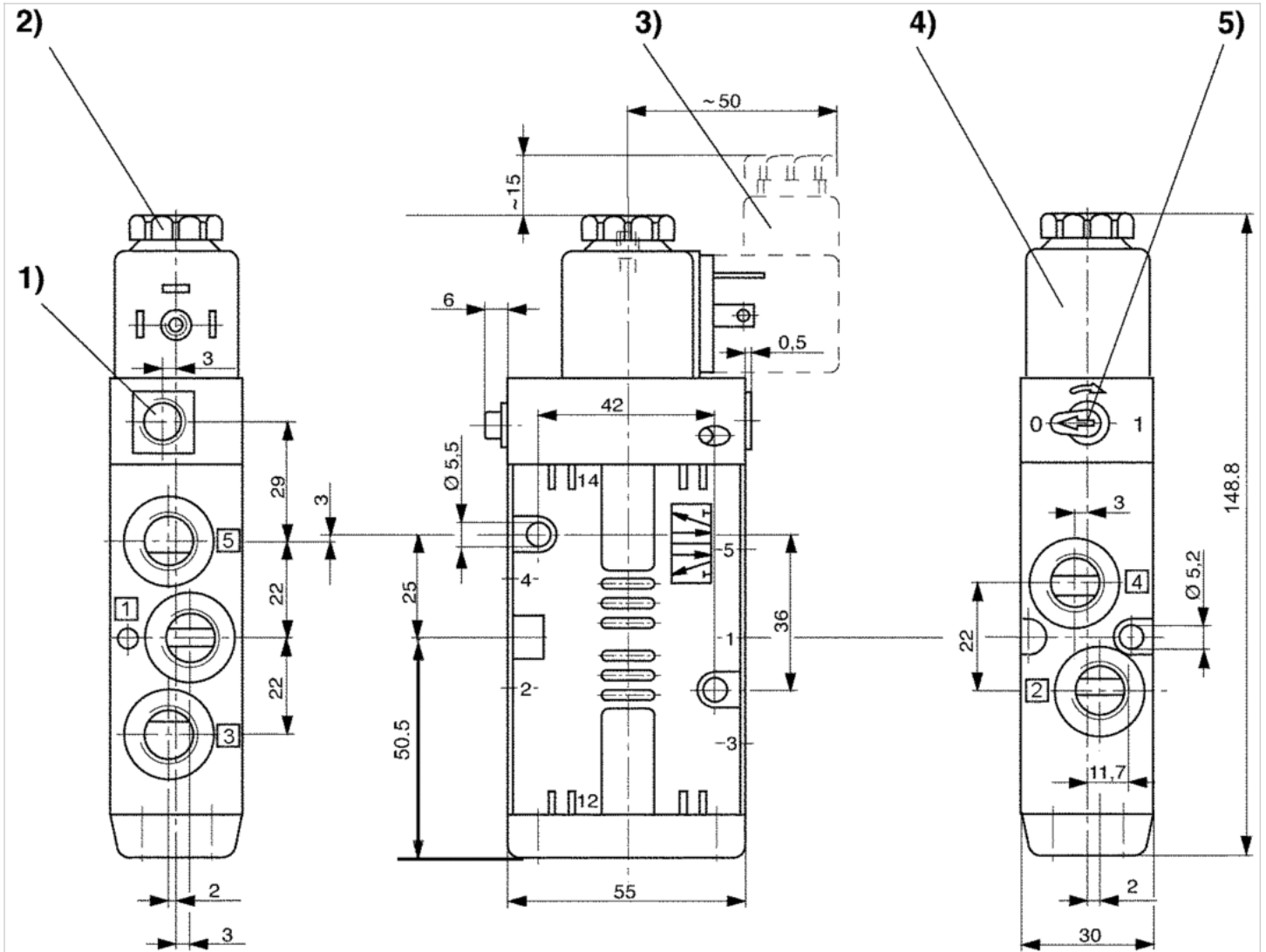

1) Only with separate pilot control G 1/8 2) After removal of cap M5 internal thread 3) Valve plug connector 4) Coil can be plugged at 45° intervals 5) Manual override







5/2-directional valve, Series CD07

- 5/2
- Qn = 1200 l/min
- Pilot valve width : 30 mm
- Pipe connection
- Compressed air connection output : G 1/4
- Electrical connection : Plug, EN 175301-803, form A, 3-pin
- -40 °C cold-resistant
- Manual override : with detent
- double solenoid
- Pilot : Internal



Version	Spool valve, positive overlapping
Activation	Electrically
Pilot	Internal
Sealing principle	Soft sealing
Working pressure min./max.	3 ... 10 bar
Control pressure min./max.	3 ... 10 bar
Ambient temperature min./max.	-40 ... 50 °C
Medium temperature min./max.	-40 ... 50 °C
Medium	Compressed air
Max. particle size	50 µm
Oil content of compressed air	0 ... 1 mg/m ³
Nominal flow Qn	1200 l/min
Nominal flow 1 ► 2	1200 l/min
Nominal flow 2 ► 3	1200 l/min
Compressed air connection	according to ISO 228-1
Pilot control exhaust	with directional pilot air exhaust
Connector standard	EN 175301-803:2006
Reverse polarity protection	Protected against polarity reversal
Compatibility index	13 14
Duty cycle	100 %
Mounting on manifold strip	P-strip PRS strip
Weight	0.75 kg

Technical data

Part No.		MO	Compressed air connection	
			Input	Output
5776840220			G 1/4	G 1/4
5776845280			G 1/4	G 1/4
5776845302			G 1/4	G 1/4

Part No.	Compressed air connection	
	Exhaust	Pilot Exhaust
5776840220	G 1/4	M5
5776845280	G 1/4	M5
5776845302	G 1/4	M5

Part No.	Operational voltage		Operational voltage	
	DC	AC 50 Hz	AC 50 Hz	AC 60 Hz
5776840220	24 V	-	-	-
5776845280	-	230 V	230 V	230 V
5776845302	-	-	-	-

Part No.	Voltage tolerance		Voltage tolerance		Power consumption
	DC	AC 50 Hz	AC 50 Hz	AC 60 Hz	DC
5776840220	-10% / +10%	-	-	-	2.1 W
5776845280	-	-20% / +10%	-10% / +20%	-	-
5776845302	-	-	-	-	-

Part No.	Holding power		Switch-on power	
	AC 50 Hz	AC 60 Hz	AC 50 Hz	AC 60 Hz
5776840220	-	-	-	-
5776845280	4.8 VA	4.1 VA	6.9 VA	5.8 VA
5776845302	-	-	-	-

Part No.	Typ. switch-on time	Typ. switch-off time	Protection class	
			with connection	basic valve with electrical connector
5776840220	21 ms	21 ms	IP65	-
5776845280	21 ms	21 ms	IP65	-
5776845302	-	-	-	Basic valve without coil

Part No.	ATEX
5776840220	-
5776845280	-
5776845302	ATEX optional

Nominal flow Q_n at 6 bar and Δp = 1 bar, MO = Manual override

Technical information

The min. control pressure must be adhered to, since otherwise faulty switching and valve failure may result!
 The pressure dew point must be at least 15 °C under ambient and medium temperature and may not exceed 3 °C .
 The oil content of compressed air must remain constant during the life cycle.
 Use only the approved oils from AVENTICS. Further information can be found in the “Technical information” document (available in the MediaCentre).

Technical information

Housing	Die cast zinc Polyamide fiber-glass reinforced Die cast zinc Polyarylamide, fiber-glass reinforced
---------	--

Dimensions

Dimensions, Fig. 1

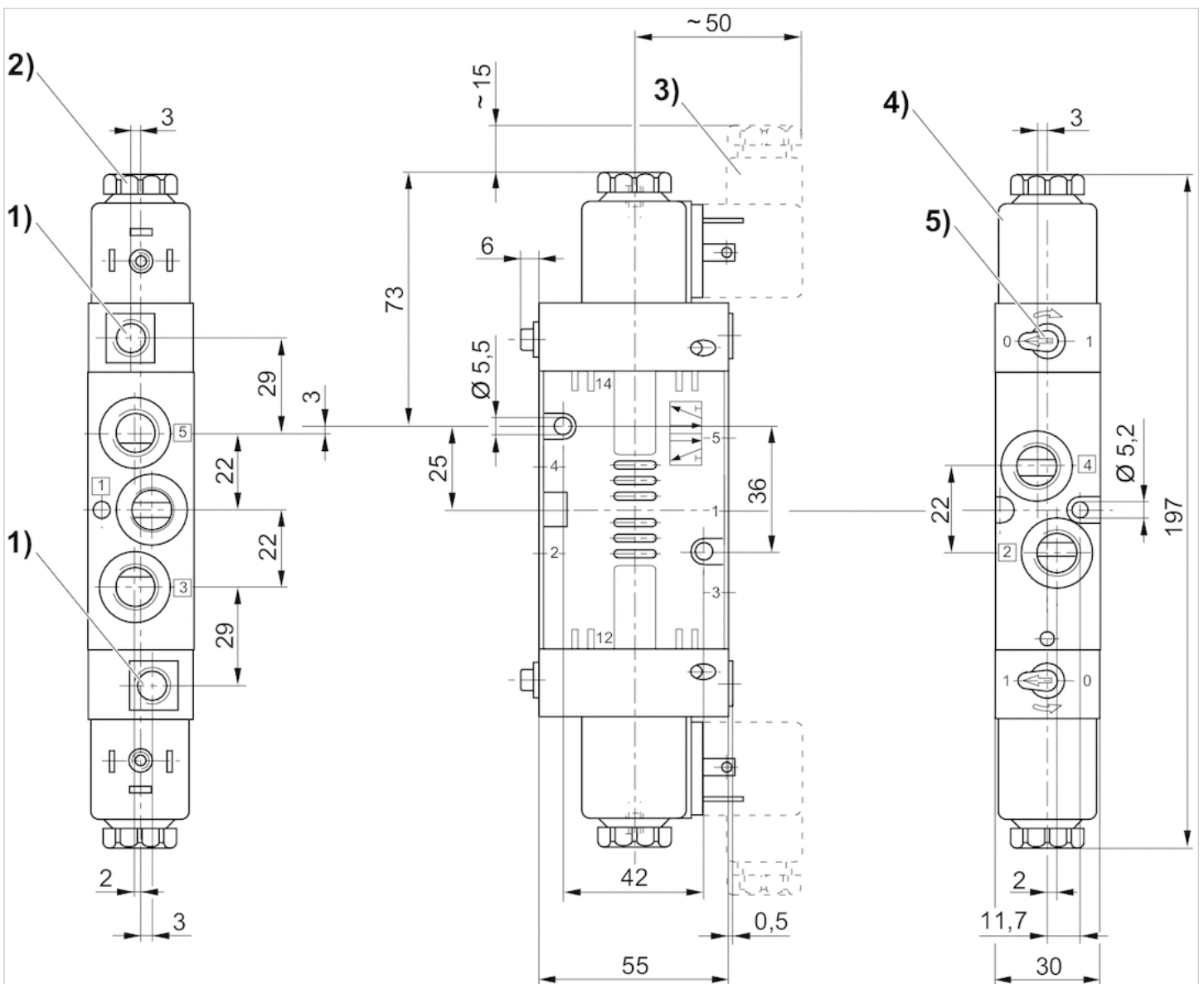

1) Only with separate pilot control G 1/8 2) After removal of cap M5 internal thread 3) Valve plug connector 4) Coil can be plugged at 45° intervals 5) Manual override







5/2-directional valve, Series CD07

- 5/2
- Qn = 1200 l/min
- Pilot valve width : 30 mm
- Pipe connection
- Compressed air connection output : G 1/4
- Electrical connection : Plug, EN 175301-803, form A, 3-pin
- -40 °C cold-resistant
- Manual override : with detent
- single solenoid
- With spring return
- Pilot : Internal



Version	Spool valve, positive overlapping
Activation	Electrically
Pilot	Internal
Sealing principle	Soft sealing
Working pressure min./max.	3.5 ... 10 bar
Control pressure min./max.	3.5 ... 10 bar
Ambient temperature min./max.	-40 ... 50 °C
Medium temperature min./max.	-40 ... 50 °C
Medium	Compressed air
Max. particle size	50 µm
Oil content of compressed air	0 ... 1 mg/m ³
Nominal flow Qn	1200 l/min
Nominal flow 1 ► 2	1200 l/min
Nominal flow 2 ► 3	1200 l/min
Compressed air connection	according to ISO 228-1
Pilot control exhaust	with directional pilot air exhaust
Connector standard	EN 175301-803:2006
Reverse polarity protection	Protected against polarity reversal
Compatibility index	13 14
Duty cycle	100 %
Typ. switch-on time	25 ms
Typ. switch-off time	45 ms
Mounting on manifold strip	P-strip PRS strip
Weight	0.57 kg

Technical data

Part No.		MO	Compressed air connection	
			Input	Output
5776960220			G 1/4	G 1/4
5776965280			G 1/4	G 1/4
5776965302			G 1/4	G 1/4

Part No.	Compressed air connection	
	Exhaust	Pilot Exhaust
5776960220	G 1/4	M5
5776965280	G 1/4	M5
5776965302	G 1/4	M5

Part No.	Operational voltage		Operational voltage	
	DC	AC 50 Hz	AC 50 Hz	AC 60 Hz
5776960220	24 V	-	-	-
5776965280	-	230 V	230 V	230 V
5776965302	-	-	-	-

Part No.	Voltage tolerance		Voltage tolerance		Power consumption
	DC	AC 50 Hz	AC 50 Hz	AC 60 Hz	DC
5776960220	-10% / +10%	-	-	-	2.1 W
5776965280	-	-20% / +10%	-10% / +20%	-	-
5776965302	-	-	-	-	-

Part No.	Holding power		Switch-on power	
	AC 50 Hz	AC 60 Hz	AC 50 Hz	AC 60 Hz
5776960220	-	-	-	-
5776965280	4.8 VA	4.1 VA	6.9 VA	5.8 VA
5776965302	-	-	-	-

Part No.	Protection class		basic valve with electrical connector	ATEX
	with connection			
5776960220	IP65		-	-
5776965280	IP65		-	-
5776965302	-		Basic valve without coil	ATEX optional

Nominal flow Q_n at 6 bar and $\Delta p = 1$ bar, MO = Manual override

Technical information

The min. control pressure must be adhered to, since otherwise faulty switching and valve failure may result!

The pressure dew point must be at least 15 °C under ambient and medium temperature and may not exceed 3 °C .

The oil content of compressed air must remain constant during the life cycle.

Use only the approved oils from AVENTICS. Further information can be found in the "Technical information" document (available in the MediaCentre).

Technical information

Housing	Die cast zinc Polyamide fiber-glass reinforced
---------	--

Dimensions

Dimensions

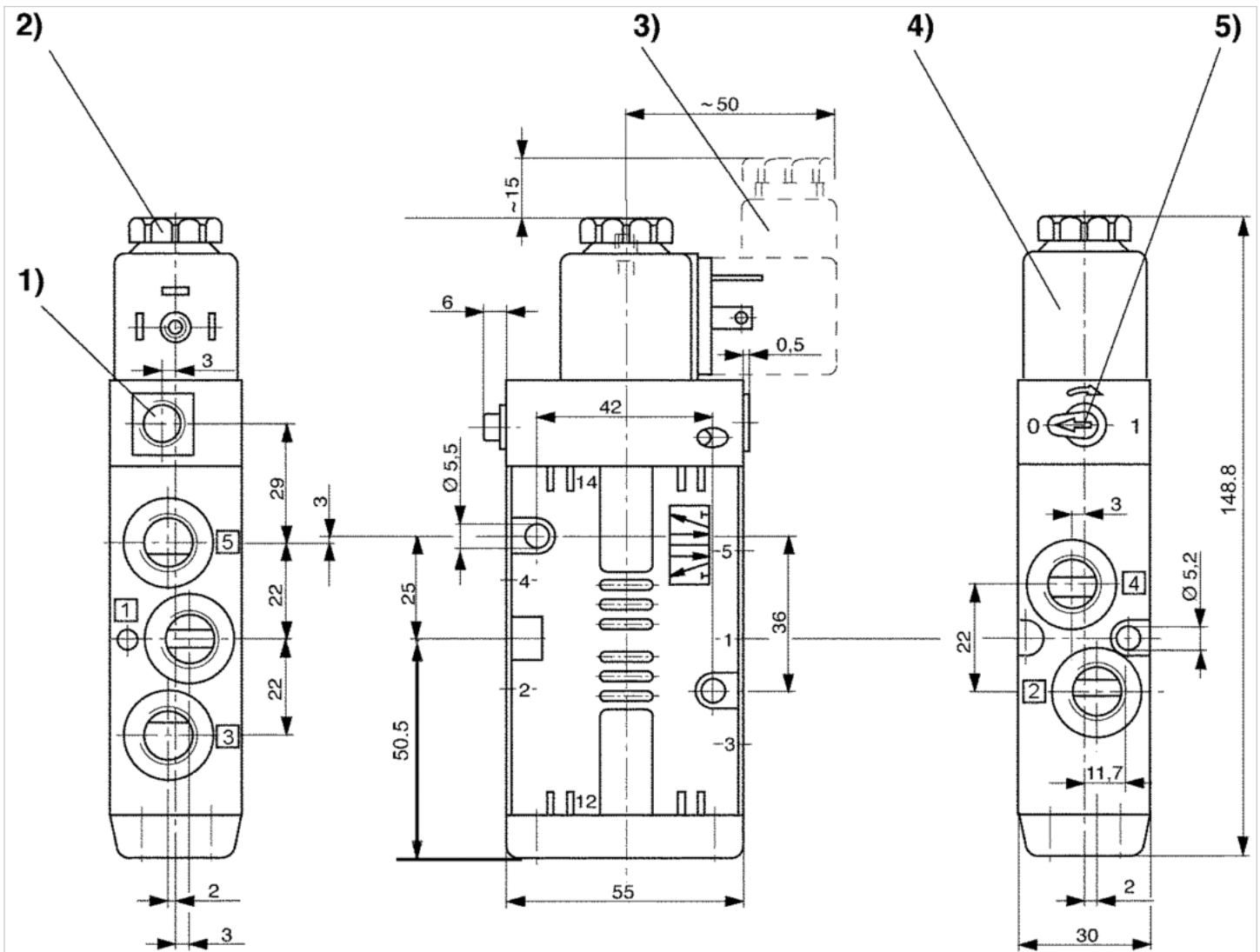

1) Only with separate pilot control G 1/8 2) After removal of cap M5 internal thread 3) Valve plug connector 4) Coil can be plugged at 45° intervals 5) Manual override

5/2-directional valve, Series CD07

- 5/2
- Qn = 1200 l/min
- Pilot valve width : 30 mm
- Pipe connection
- Compressed air connection output : G 1/4
- Electrical connection : Plug, EN 175301-803, form A, 3-pin
- -25 °C cold-resistant
- Manual override : with detent
- double solenoid
- Pilot : Internal External



Version	Spool valve, positive overlapping
Activation	Electrically
Sealing principle	Soft sealing
Working pressure min./max.	See table below
Control pressure min./max.	2 ... 10 bar
Ambient temperature min./max.	-25 ... 50 °C
Medium temperature min./max.	-25 ... 50 °C
Medium	Compressed air
Max. particle size	50 µm
Oil content of compressed air	0 ... 1 mg/m ³
Nominal flow Qn	1200 l/min
Nominal flow 1 ► 2	1200 l/min
Nominal flow 2 ► 3	1200 l/min
Compressed air connection	according to ISO 228-1
Pilot control exhaust	with directional pilot air exhaust
Connector standard	EN 175301-803:2006
Reverse polarity protection	Protected against polarity reversal
Compatibility index	13 14
Duty cycle	100 %
Mounting on manifold strip	P-strip PRS strip
Weight	See table below

Technical data

Part No.		MO	Compressed air connection	
			Input	
5776270220			G 1/4	
5776272220			G 1/4	
5776275270			G 1/4	
5776275280			G 1/4	
5776275220			G 1/4	
5776275302			G 1/4	
5776280220			G 1/4	
5776285270			G 1/4	
5776285280			G 1/4	
5776285302			G 1/4	

Part No.	Compressed air connection	
	Output	Exhaust
5776270220	G 1/4	G 1/4
5776272220	G 1/4	G 1/4
5776275270	G 1/4	G 1/4
5776275280	G 1/4	G 1/4
5776275220	G 1/4	G 1/4
5776275302	G 1/4	G 1/4
5776280220	G 1/4	G 1/4
5776285270	G 1/4	G 1/4
5776285280	G 1/4	G 1/4
5776285302	G 1/4	G 1/4

Part No.	Compressed air connection	
	Pilot Input	Pilot Exhaust
5776270220	-	-
5776272220	-	-
5776275270	-	-
5776275280	-	-
5776275220	-	-
5776275302	-	-
5776280220	G 1/8	M5
5776285270	G 1/8	M5
5776285280	G 1/8	M5
5776285302	G 1/8	M5

Part No.	Operational voltage		Operational voltage	
	DC	AC 50 Hz	AC 60 Hz	
5776270220	24 V	-	-	
5776272220	24 V	-	-	
5776275270	-	110 V	110 V	
5776275280	-	230 V	230 V	
5776275220	-	24 V	24 V	
5776275302	-	-	-	
5776280220	24 V	-	-	

Part No.	Operational voltage	Operational voltage	Operational voltage
	DC	AC 50 Hz	AC 60 Hz
5776285270	-	110 V	110 V
5776285280	-	230 V	230 V
5776285302	-	-	-

Part No.	Voltage tolerance	Voltage tolerance	Voltage tolerance	Power consumption
	DC	AC 50 Hz	AC 60 Hz	DC
5776270220	-10% / +10%	-	-	2.1 W
5776272220	-20% / +30%	-	-	4.5 W
5776275270	-	-20% / +10%	-10% / +20%	-
5776275280	-	-20% / +10%	-10% / +20%	-
5776275220	-	-20% / +10%	-10% / +20%	-
5776275302	-	-	-	-
5776280220	-10% / +10%	-	-	2.1 W
5776285270	-	-20% / +10%	-10% / +20%	-
5776285280	-	-20% / +10%	-10% / +20%	-
5776285302	-	-	-	-

Part No.	Holding power	Holding power	Switch-on power	Switch-on power	Pilot
	AC 50 Hz	AC 60 Hz	AC 50 Hz	AC 60 Hz	
5776270220	-	-	-	-	Internal
5776272220	-	-	-	-	Internal
5776275270	4.3 VA	3.3 VA	6.8 VA	5.7 VA	Internal
5776275280	4.8 VA	4.1 VA	6.9 VA	5.8 VA	Internal
5776275220	4.3 VA	3.2 VA	6.9 VA	5.6 VA	Internal
5776275302	-	-	-	-	Internal
5776280220	-	-	-	-	External
5776285270	4.3 VA	3.3 VA	6.8 VA	5.7 VA	External
5776285280	4.8 VA	4.1 VA	6.9 VA	5.8 VA	External
5776285302	-	-	-	-	External

Part No.	Working pressure min./max.	Typ. switch-on time	Typ. switch-off time	Protection class
				with connection
5776270220	2 ... 10 bar	21 ms	21 ms	IP65
5776272220	2 ... 10 bar	21 ms	21 ms	IP65
5776275270	2 ... 10 bar	21 ms	21 ms	IP65
5776275280	2 ... 10 bar	21 ms	21 ms	IP65
5776275220	2 ... 10 bar	21 ms	21 ms	IP65
5776275302	2 ... 10 bar	-	-	-
5776280220	-0.95 ... 10 bar	21 ms	21 ms	IP65
5776285270	-0.95 ... 10 bar	21 ms	21 ms	IP65
5776285280	-0.95 ... 10 bar	21 ms	21 ms	IP65
5776285302	-0.95 ... 10 bar	-	-	-

Part No.	basic valve with electrical connector	Power consumption	ATEX
5776270220	-	-	-
5776272220	-	Higher power consumption	-
5776275270	-	-	-
5776275280	-	-	-

Part No.	basic valve with electrical connector	Power consumption	ATEX
5776275220	-	-	-
5776275302	Basic valve without coil	-	ATEX optional
5776280220	-	-	-
5776285270	-	-	-
5776285280	-	-	-
5776285302	Basic valve without coil	-	ATEX optional

Part No.	Weight
5776270220	0.75 kg
5776272220	0.75 kg
5776275270	0.75 kg
5776275280	0.75 kg
5776275220	0.75 kg
5776275302	-
5776280220	0.75 kg
5776285270	0.75 kg
5776285280	0.75 kg
5776285302	-

Nominal flow Q_n at 6 bar and $\Delta p = 1$ bar, MO = Manual override

Technical information

The min. control pressure must be adhered to, since otherwise faulty switching and valve failure may result!

The pressure dew point must be at least 15 °C under ambient and medium temperature and may not exceed 3 °C .

The oil content of compressed air must remain constant during the life cycle.

Use only the approved oils from AVENTICS. Further information can be found in the "Technical information" document (available in the MediaCentre).

ATEX optional: ATEX version can be produced by combining the basic valve without coil with an ATEX coil. ATEX ID: see ATEX coils catalog page.

Technical information

Material	
Housing	Die cast zinc Polyamide fiber-glass reinforced
Seals	Acrylonitrile butadiene rubber

Dimensions

Dimensions, Fig. 1

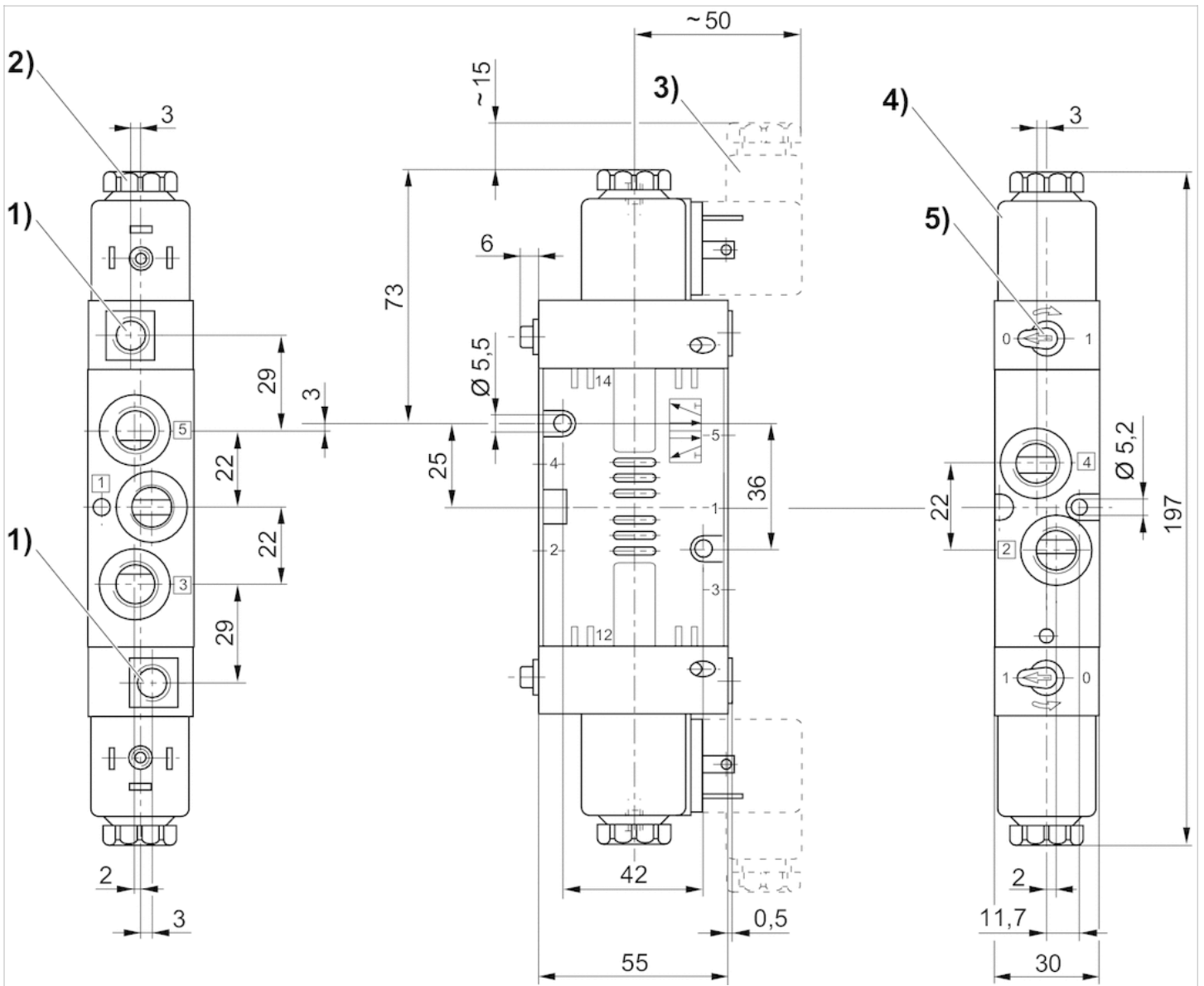

1) Only with separate pilot control G 1/8 2) After removal of cap M5 internal thread 3) Valve plug connector 4) Coil can be plugged at 45° intervals 5) Manual override















5/2-directional valve, Series CD07

- 5/2
- Qn = 1200 l/min
- Pilot valve width : 30 mm
- Pipe connection
- Compressed air connection output : M14x1,5
- Electrical connection : Plug, EN 175301-803, form A, 3-pin
- -25 °C cold-resistant
- Manual override : with detent
- single solenoid
- With spring return
- Pilot : Internal External



Version	Spool valve, positive overlapping
Activation	Electrically
Sealing principle	Soft sealing
Working pressure min./max.	See table below
Control pressure min./max.	3 ... 10 bar
Ambient temperature min./max.	-25 ... 50 °C
Medium temperature min./max.	-25 ... 50 °C
Medium	Compressed air
Max. particle size	50 µm
Oil content of compressed air	0 ... 1 mg/m ³
Nominal flow Qn	1200 l/min
Nominal flow 1 ► 2	1200 l/min
Nominal flow 2 ► 3	1200 l/min
Pilot control exhaust	with directional pilot air exhaust
Connector standard	EN 175301-803:2006
Reverse polarity protection	Protected against polarity reversal
Compatibility index	13 14
Duty cycle	100 %
Mounting on manifold strip	P-strip PRS strip
Weight	See table below

Technical data

Part No.		MO	Compressed air connection	
			Input	Output
5776020220			M14x1,5	M14x1,5
5776025270			M14x1,5	M14x1,5
5776025280			M14x1,5	M14x1,5
5776025302			M14x1,5	M14x1,5
5776030220			M14x1,5	M14x1,5
5776035280			M14x1,5	M14x1,5
5776035302			M14x1,5	M14x1,5

Part No.	Compressed air connection	
	Exhaust	Pilot Input
5776020220	M14x1,5	-
5776025270	M14x1,5	-
5776025280	M14x1,5	-
5776025302	M14x1,5	-
5776030220	M14x1,5	G 1/8
5776035280	M14x1,5	G 1/8
5776035302	M14x1,5	G 1/8

Part No.	Compressed air connection		Operational voltage	
	Pilot Exhaust	DC	AC 50 Hz	
5776020220	M5	24 V	-	
5776025270	M5	-	110 V	
5776025280	M5	-	230 V	
5776025302	M5	-	-	
5776030220	M5	24 V	-	
5776035280	M5	-	230 V	
5776035302	M5	-	-	

Part No.	Operational voltage		Voltage tolerance		
	AC 60 Hz	DC	AC 50 Hz	AC 60 Hz	
5776020220	-	-10% / +10%	-	-	
5776025270	110 V	-	-20% / +10%	-10% / +20%	
5776025280	230 V	-	-20% / +10%	-10% / +20%	
5776025302	-	-	-	-	
5776030220	-	-10% / +10%	-	-	
5776035280	230 V	-	-20% / +10%	-10% / +20%	
5776035302	-	-	-	-	

Part No.	Power consumption		Holding power		Switch-on power
	DC	AC 50 Hz	AC 60 Hz	AC 50 Hz	
5776020220	2.1 W	-	-	-	
5776025270	-	4.3 VA	3.3 VA	6.8 VA	
5776025280	-	4.8 VA	4.1 VA	6.9 VA	
5776025302	-	-	-	-	
5776030220	2.1 W	-	-	-	

Part No.	Power consumption	Holding power	Holding power	Switch-on power
	DC	AC 50 Hz	AC 60 Hz	AC 50 Hz
5776035280	-	4.8 VA	4.1 VA	6.9 VA
5776035302	-	-	-	-

Part No.	Switch-on power	Pilot	Working pressure min./max.	Typ. switch-on time	Typ. switch-off time
	AC 60 Hz				
5776020220	-	Internal	3 ... 10 bar	25 ms	45 ms
5776025270	5.7 VA	Internal	3 ... 10 bar	25 ms	45 ms
5776025280	5.8 VA	Internal	3 ... 10 bar	25 ms	45 ms
5776025302	-	Internal	3 ... 10 bar	-	-
5776030220	-	External	-0.95 ... 10 bar	25 ms	45 ms
5776035280	5.8 VA	External	-0.95 ... 10 bar	25 ms	45 ms
5776035302	-	External	-0.95 ... 10 bar	-	-

Part No.	Protection class	basic valve with electrical connector	ATEX	Weight
	with connection			
5776020220	IP65	-	-	0.57 kg
5776025270	IP65	-	-	0.57 kg
5776025280	IP65	-	-	0.57 kg
5776025302	-	Basic valve without coil	ATEX optional	-
5776030220	IP65	-	-	0.57 kg
5776035280	IP65	-	-	0.57 kg
5776035302	-	Basic valve without coil	ATEX optional	-

Nominal flow Qn at 6 bar and $\Delta p = 1$ bar, MO = Manual override

Technical information

The min. control pressure must be adhered to, since otherwise faulty switching and valve failure may result!

The pressure dew point must be at least 15 °C under ambient and medium temperature and may not exceed 3 °C .

The oil content of compressed air must remain constant during the life cycle.

Use only the approved oils from AVENTICS. Further information can be found in the "Technical information" document (available in the MediaCentre).

ATEX optional: ATEX version can be produced by combining the basic valve without coil with an ATEX coil. ATEX ID: see ATEX coils catalog page.

Technical information

Material	
Housing	Die cast zinc Polyamide fiber-glass reinforced Polyamide fiber-glass reinforced Die cast zinc
Seals	Acrylonitrile butadiene rubber

Dimensions

Dimensions

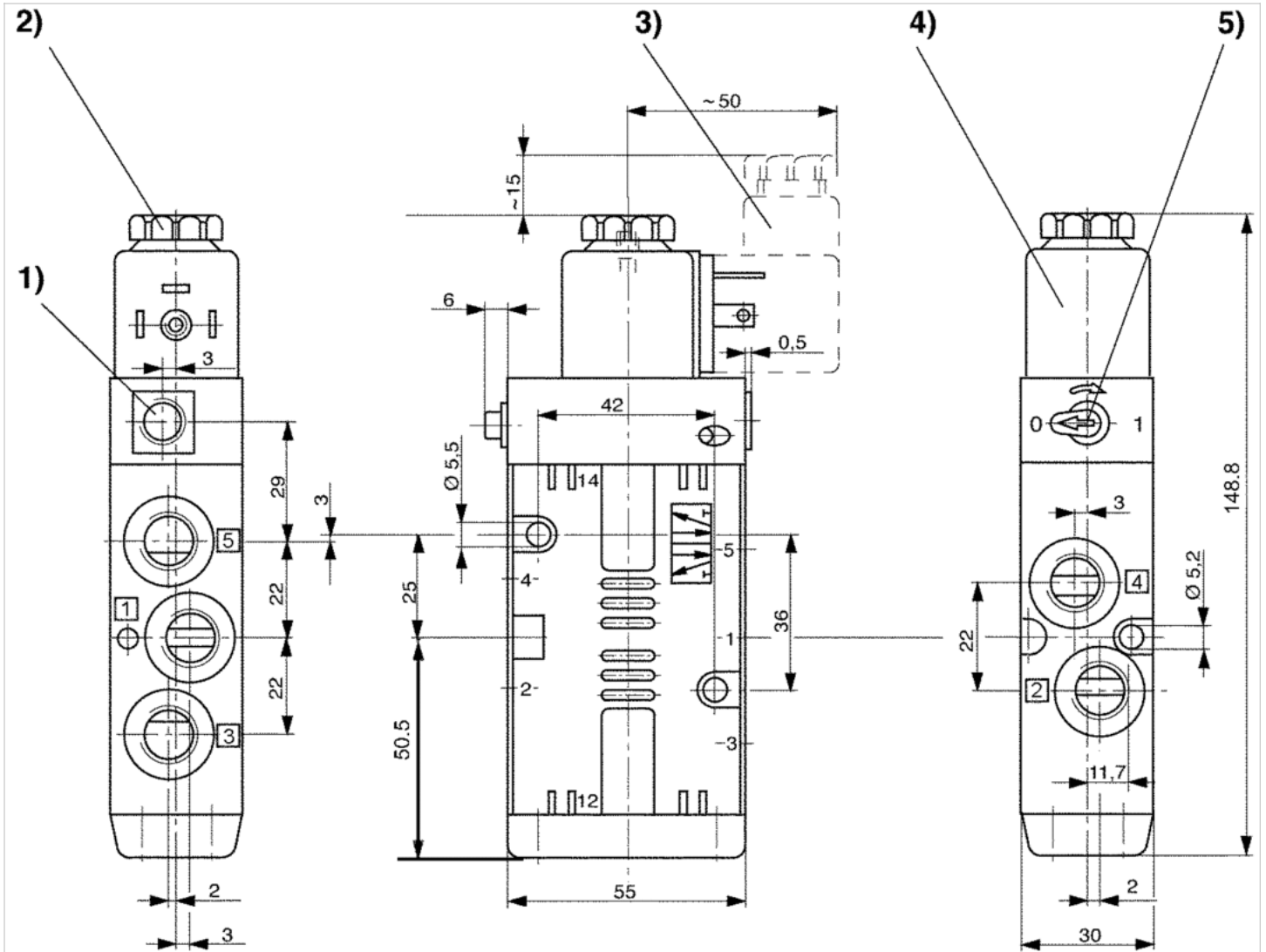

1) Only with separate pilot control G 1/8 2) After removal of cap M5 internal thread 3) Valve plug connector 4) Coil can be plugged at 45° intervals 5) Manual override













5/2-directional valve, Series CD07

- 5/2
- Qn = 1200 l/min
- Pilot valve width : 30 mm
- Pipe connection
- Compressed air connection output : M14x1,5
- Electrical connection : Plug, EN 175301-803, form A, 3-pin
- -25 °C cold-resistant
- Manual override : with detent
- double solenoid
- Pilot : Internal External



Version	Spool valve, positive overlapping
Activation	Electrically
Sealing principle	Soft sealing
Working pressure min./max.	See table below
Control pressure min./max.	2 ... 10 bar
Ambient temperature min./max.	-25 ... 50 °C
Medium temperature min./max.	-25 ... 50 °C
Medium	Compressed air
Max. particle size	50 µm
Oil content of compressed air	0 ... 1 mg/m ³
Nominal flow Qn	1200 l/min
Nominal flow 1 ► 2	1200 l/min
Nominal flow 2 ► 3	1200 l/min
Pilot control exhaust	with directional pilot air exhaust
Connector standard	EN 175301-803:2006
Reverse polarity protection	Protected against polarity reversal
Compatibility index	13 14
Duty cycle	100 %
Mounting on manifold strip	P-strip PRS strip
Weight	0.75 kg

Technical data

Part No.		MO	Compressed air connection	
			Input	Output
5776220220			M14x1,5	M14x1,5
5776225280			M14x1,5	M14x1,5
5776225302			M14x1,5	M14x1,5
5776230220			M14x1,5	M14x1,5
5776235280			M14x1,5	M14x1,5
5776235302			M14x1,5	M14x1,5

Part No.	Compressed air connection	
	Exhaust	Pilot Input
5776220220	M14x1,5	-
5776225280	M14x1,5	-
5776225302	M14x1,5	-
5776230220	M14x1,5	G 1/8
5776235280	M14x1,5	G 1/8
5776235302	M14x1,5	G 1/8

Part No.	Compressed air connection		Operational voltage	
	Pilot Exhaust		DC	AC 50 Hz
5776220220	M5		24 V	-
5776225280	M5		-	230 V
5776225302	M5		-	-
5776230220	M5		24 V	-
5776235280	M5		-	230 V
5776235302	M5		-	-

Part No.	Operational voltage		Voltage tolerance	
	AC 60 Hz		DC	AC 50 Hz
5776220220	-		-10% / +10%	-
5776225280	230 V		-	-20% / +10%
5776225302	-		-	-
5776230220	-		-10% / +10%	-
5776235280	230 V		-	-20% / +10%
5776235302	-		-	-

Part No.	Power consumption		Holding power		Switch-on power
	DC		AC 50 Hz	AC 60 Hz	AC 50 Hz
5776220220	2.1 W		-	-	-
5776225280	-		4.8 VA	4.1 VA	6.9 VA
5776225302	-		-	-	-
5776230220	2.1 W		-	-	-
5776235280	-		4.8 VA	4.1 VA	6.9 VA
5776235302	-		-	-	-

Part No.	Switch-on power		Pilot	Working pressure min./max.	Typ. switch-on time	Typ. switch-off time
	AC 60 Hz					
5776220220	-		Internal	2 ... 10 bar	21 ms	21 ms

Part No.	Switch-on power	Pilot	Working pressure min./max.	Typ. switch-on time	Typ. switch-off time
	AC 60 Hz				
5776225280	5.8 VA	Internal	2 ... 10 bar	21 ms	21 ms
5776225302	-	Internal	2 ... 10 bar	-	-
5776230220	-	External	-0.95 ... 10 bar	21 ms	21 ms
5776235280	5.8 VA	External	-0.95 ... 10 bar	21 ms	21 ms
5776235302	-	External	-0.95 ... 10 bar	-	-

Part No.	Protection class	basic valve with electrical connector	ATEX
	with connection		
5776220220	IP65	-	-
5776225280	IP65	-	-
5776225302	-	Basic valve without coil	ATEX optional
5776230220	IP65	-	-
5776235280	IP65	-	-
5776235302	-	Basic valve without coil	ATEX optional

Nominal flow Q_n at 6 bar and $\Delta p = 1$ bar, MO = Manual override

Technical information

The min. control pressure must be adhered to, since otherwise faulty switching and valve failure may result!

The pressure dew point must be at least 15 °C under ambient and medium temperature and may not exceed 3 °C .

The oil content of compressed air must remain constant during the life cycle.

Use only the approved oils from AVENTICS. Further information can be found in the "Technical information" document (available in the MediaCentre).

ATEX optional: ATEX version can be produced by combining the basic valve without coil with an ATEX coil. ATEX ID: see ATEX coils catalog page.

Technical information

Material	
Housing	Die cast zinc Polyamide fiber-glass reinforced
Seals	Acrylonitrile butadiene rubber

Dimensions

Dimensions, Fig. 1

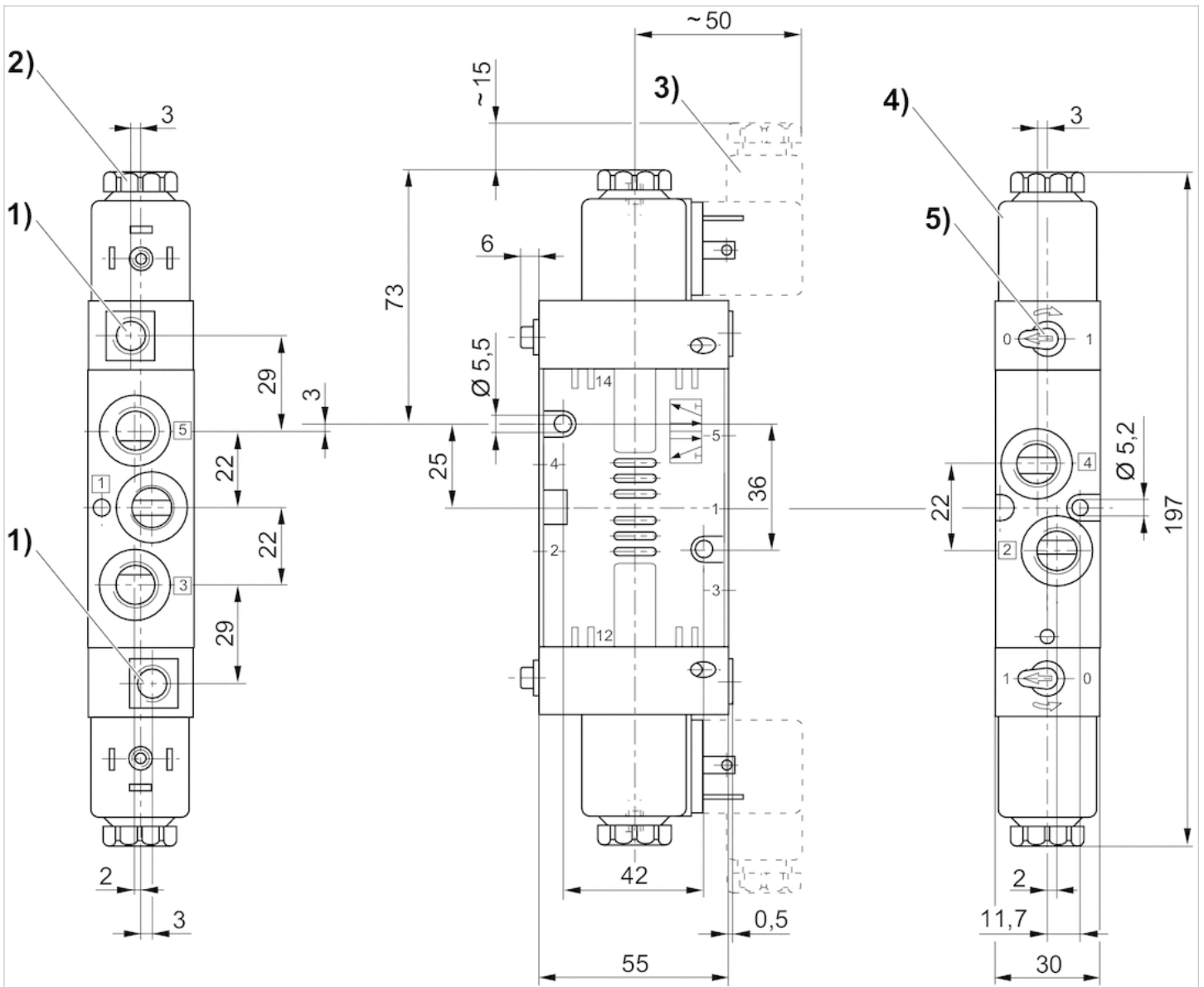

1) Only with separate pilot control G 1/8 2) After removal of cap M5 internal thread 3) Valve plug connector 4) Coil can be plugged at 45° intervals 5) Manual override

5/3-directional valve, Series CD07

- 5/3
- Qn = 900 l/min
- Pilot valve width : 30 mm
- closed center exhausted center pressurized center
- Pipe connection
- Compressed air connection output : G 1/4
- Electrical connection : Plug, EN 175301-803, form A, 3-pin
- -25 °C cold-resistant
- Manual override : with detent
- double solenoid
- With spring return
- Pilot : Internal External



Version	Spool valve, positive overlapping
Activation	Electrically
Sealing principle	Soft sealing
Working pressure min./max.	See table below
Control pressure min./max.	3 ... 10 bar
Ambient temperature min./max.	See table below
Medium temperature min./max.	See table below
Medium	Compressed air
Max. particle size	50 µm
Oil content of compressed air	0 ... 1 mg/m ³
Nominal flow Qn	900 l/min
Nominal flow 1 ▶ 2	See table below
Nominal flow 2 ▶ 3	See table below
Compressed air connection	according to ISO 228-1
Pilot control exhaust	with directional pilot air exhaust
Connector standard	EN 175301-803:2006
Reverse polarity protection	Protected against polarity reversal
Compatibility index	13 14
Duty cycle	100 %
Mounting on manifold strip	P-strip PRS strip
Weight	See table below

Technical data

Part No.		MO		Compressed air connection	
				Input	
5777770220			closed center		G 1/4
5777775270			closed center		G 1/4
5777775280			closed center		G 1/4
5777775220			closed center		G 1/4
5777775302			closed center		G 1/4
5777955302			closed center		G 1/4
5777720220			closed center		G 1/4
5777725280			closed center		G 1/4
5777725302			closed center		G 1/4
R412003424			closed center		G 1/4
5777955280			closed center		G 1/4
5777760220			exhausted center		G 1/4
5777765270			exhausted center		G 1/4
5777765280			exhausted center		G 1/4
5777765302			exhausted center		G 1/4
5777945302			exhausted center		G 1/4
5777710220			exhausted center		G 1/4
5777715280			exhausted center		G 1/4
5777715302			exhausted center		G 1/4
5777750220			pressurized center		G 1/4
5777755280			pressurized center		G 1/4
5777755302			pressurized center		G 1/4
5777700220			pressurized center		G 1/4
5777705302			pressurized center		G 1/4

Part No.	Compressed air connection	
	Output	Exhaust
5777770220	G 1/4	G 1/4
5777775270	G 1/4	G 1/4
5777775280	G 1/4	G 1/4
5777775220	G 1/4	G 1/4
5777775302	G 1/4	G 1/4
5777955302	G 1/4	G 1/4
5777720220	G 1/4	G 1/4
5777725280	G 1/4	G 1/4
5777725302	G 1/4	G 1/4
R412003424	G 1/4	G 1/4
5777955280	G 1/4	G 1/4
5777760220	G 1/4	G 1/4
5777765270	G 1/4	G 1/4
5777765280	G 1/4	G 1/4
5777765302	G 1/4	G 1/4
5777945302	G 1/4	G 1/4
5777710220	G 1/4	G 1/4
5777715280	G 1/4	G 1/4
5777715302	G 1/4	G 1/4

Part No.	Compressed air connection	
	Output	Exhaust
5777750220	G 1/4	G 1/4
5777755280	G 1/4	G 1/4
5777755302	G 1/4	G 1/4
5777700220	G 1/4	G 1/4
5777705302	G 1/4	G 1/4

Part No.	Compressed air connection	
	Pilot Input	Pilot Exhaust
5777770220	-	M5
5777775270	-	M5
5777775280	-	M5
5777775220	-	M5
5777775302	-	M5
5777955302	G 1/8	M5
5777720220	-	M5
5777725280	-	M5
5777725302	-	M5
R412003424	G 1/8	M5
5777955280	G 1/8	M5
5777760220	-	M5
5777765270	-	M5
5777765280	-	M5
5777765302	-	M5
5777945302	G 1/8	M5
5777710220	-	M5
5777715280	-	M5
5777715302	-	M5
5777750220	-	M5
5777755280	-	M5
5777755302	-	M5
5777700220	-	M5
5777705302	-	M5

Part No.	Operational voltage		
	DC	AC 50 Hz	AC 60 Hz
5777770220	24 V	-	-
5777775270	-	110 V	110 V
5777775280	-	230 V	230 V
5777775220	-	24 V	24 V
5777775302	-	-	-
5777955302	-	-	-
5777720220	24 V	-	-
5777725280	-	230 V	230 V
5777725302	-	-	-
R412003424	24 V	-	-
5777955280	-	230 V	230 V
5777760220	24 V	-	-
5777765270	-	110 V	110 V

Part No.	Operational voltage	Operational voltage	Operational voltage
	DC	AC 50 Hz	AC 60 Hz
5777765280	-	230 V	230 V
5777765302	-	-	-
5777945302	-	-	-
5777710220	24 V	-	-
5777715280	-	230 V	230 V
5777715302	-	-	-
5777750220	24 V	-	-
5777755280	-	230 V	230 V
5777755302	-	-	-
5777700220	24 V	-	-
5777705302	-	-	-

Part No.	Voltage tolerance	Voltage tolerance	Voltage tolerance	Power consumption
	DC	AC 50 Hz	AC 60 Hz	DC
5777770220	-10% / +10%	-	-	2.1 W
5777775270	-	-20% / +10%	-10% / +20%	-
5777775280	-	-20% / +10%	-10% / +20%	-
5777775220	-	-20% / +10%	-10% / +20%	-
5777775302	-	-	-	-
5777955302	-	-	-	-
5777720220	-10% / +10%	-	-	2.1 W
5777725280	-	-20% / +10%	-10% / +20%	-
5777725302	-	-	-	-
R412003424	-10% / +10%	-	-	2.1 W
5777955280	-	-20% / +10%	-10% / +20%	-
5777760220	-10% / +10%	-	-	2.1 W
5777765270	-	-20% / +10%	-10% / +20%	-
5777765280	-	-20% / +10%	-10% / +20%	-
5777765302	-	-	-	-
5777945302	-	-	-	-
5777710220	-10% / +10%	-	-	2.1 W
5777715280	-	-20% / +10%	-10% / +20%	-
5777715302	-	-	-	-
5777750220	-10% / +10%	-	-	2.1 W
5777755280	-	-20% / +10%	-10% / +20%	-
5777755302	-	-	-	-
5777700220	-10% / +10%	-	-	2.1 W
5777705302	-	-	-	-

Part No.	Holding power	Holding power	Switch-on power	Switch-on power	Pilot
	AC 50 Hz	AC 60 Hz	AC 50 Hz	AC 60 Hz	
5777770220	-	-	-	-	Internal
5777775270	4.3 VA	3.3 VA	6.8 VA	5.7 VA	Internal
5777775280	4.8 VA	4.1 VA	6.9 VA	5.8 VA	Internal
5777775220	4.3 VA	3.2 VA	6.9 VA	5.6 VA	Internal
5777775302	-	-	-	-	Internal
5777955302	-	-	-	-	External
5777720220	-	-	-	-	Internal

Part No.	Holding power	Holding power	Switch-on power	Switch-on power	Pilot
	AC 50 Hz	AC 60 Hz	AC 50 Hz	AC 60 Hz	
5777725280	4.8 VA	4.1 VA	6.9 VA	5.8 VA	Internal
5777725302	-	-	-	-	Internal
R412003424	-	-	-	-	External
5777955280	4.8 VA	4.1 VA	6.9 VA	5.8 VA	External
5777760220	-	-	-	-	Internal
5777765270	4.3 VA	3.3 VA	6.8 VA	5.7 VA	Internal
5777765280	4.8 VA	4.1 VA	6.9 VA	5.8 VA	Internal
5777765302	-	-	-	-	Internal
5777945302	-	-	-	-	External
5777710220	-	-	-	-	Internal
5777715280	4.8 VA	4.1 VA	6.9 VA	5.8 VA	Internal
5777715302	-	-	-	-	Internal
5777750220	-	-	-	-	Internal
5777755280	4.8 VA	4.1 VA	6.9 VA	5.8 VA	Internal
5777755302	-	-	-	-	Internal
5777700220	-	-	-	-	Internal
5777705302	-	-	-	-	Internal

Part No.	Nominal flow 1 ▶ 2	Nominal flow 2 ▶ 3	Working pressure min./max.	Ambient temperature min./max.
5777770220	1070 l/min	950 l/min	3 ... 10 bar	-25 ... 50 °C
5777775270	1070 l/min	950 l/min	3 ... 10 bar	-25 ... 50 °C
5777775280	1070 l/min	950 l/min	3 ... 10 bar	-25 ... 50 °C
5777775220	1070 l/min	950 l/min	3 ... 10 bar	-25 ... 50 °C
5777775302	1070 l/min	950 l/min	3 ... 10 bar	-25 ... 50 °C
5777955302	1070 l/min	950 l/min	-0.95 ... 10 bar	0 ... 50 °C
5777720220	1070 l/min	950 l/min	3 ... 10 bar	-25 ... 50 °C
5777725280	1070 l/min	950 l/min	3 ... 10 bar	-25 ... 50 °C
5777725302	1070 l/min	950 l/min	3 ... 10 bar	-25 ... 50 °C
R412003424	1070 l/min	950 l/min	-0.95 ... 10 bar	0 ... 50 °C
5777955280	1070 l/min	950 l/min	-0.95 ... 10 bar	0 ... 50 °C
5777760220	1030 l/min	880 l/min	3 ... 10 bar	0 ... 50 °C
5777765270	1030 l/min	880 l/min	3 ... 10 bar	0 ... 50 °C
5777765280	1030 l/min	880 l/min	3 ... 10 bar	0 ... 50 °C
5777765302	1030 l/min	880 l/min	3 ... 10 bar	0 ... 50 °C
5777945302	1030 l/min	880 l/min	-0.95 ... 10 bar	0 ... 50 °C
5777710220	1030 l/min	880 l/min	3 ... 10 bar	-25 ... 50 °C
5777715280	1030 l/min	880 l/min	3 ... 10 bar	-25 ... 50 °C
5777715302	1030 l/min	880 l/min	3 ... 10 bar	-25 ... 50 °C
5777750220	960 l/min	900 l/min	3 ... 10 bar	0 ... 50 °C
5777755280	960 l/min	900 l/min	3 ... 10 bar	0 ... 50 °C
5777755302	960 l/min	900 l/min	3 ... 10 bar	0 ... 50 °C
5777700220	960 l/min	900 l/min	3 ... 10 bar	-25 ... 50 °C
5777705302	960 l/min	900 l/min	3 ... 10 bar	-25 ... 50 °C

Part No.	Medium temperature min./max.	Typ. switch-on time	Typ. switch-off time	Protection class
				with connection
5777770220	-25 ... 50 °C	25 ms	55 ms	IP65
5777775270	-25 ... 50 °C	25 ms	55 ms	IP65

Part No.	Medium temperature min./max.	Typ. switch-on time	Typ. switch-off time	Protection class
				with connection
577775280	-25 ... 50 °C	25 ms	55 ms	IP65
577775220	-25 ... 50 °C	25 ms	55 ms	IP65
577775302	-25 ... 50 °C	-	-	-
577795302	0 ... 50 °C	-	-	-
5777720220	-25 ... 50 °C	25 ms	55 ms	IP65
5777725280	-25 ... 50 °C	25 ms	55 ms	IP65
5777725302	-25 ... 50 °C	-	-	-
R412003424	0 ... 50 °C	-	-	IP65
5777955280	0 ... 50 °C	-	-	IP65
5777760220	0 ... 50 °C	25 ms	55 ms	IP65
5777765270	0 ... 50 °C	25 ms	55 ms	IP65
5777765280	0 ... 50 °C	25 ms	55 ms	IP65
5777765302	0 ... 50 °C	-	-	-
5777945302	0 ... 50 °C	-	-	-
5777710220	-25 ... 50 °C	25 ms	55 ms	IP65
5777715280	-25 ... 50 °C	25 ms	55 ms	IP65
5777715302	-25 ... 50 °C	-	-	-
5777750220	0 ... 50 °C	25 ms	55 ms	IP65
5777755280	0 ... 50 °C	25 ms	55 ms	IP65
5777755302	0 ... 50 °C	-	-	-
5777700220	-25 ... 50 °C	25 ms	55 ms	IP65
5777705302	-25 ... 50 °C	-	-	-

Part No.	basic valve with electrical connector	ATEX	Weight	Fig.
577770220	-	-	0.72 kg	Fig. 1
577775270	-	-	0.72 kg	Fig. 1
577775280	-	-	0.72 kg	Fig. 1
577775220	-	-	0.72 kg	Fig. 1
577775302	Basic valve without coil	ATEX optional	-	Fig. 2
577795302	Basic valve without coil	ATEX optional	-	Fig. 1
5777720220	-	-	0.72 kg	Fig. 2
5777725280	-	-	0.72 kg	Fig. 2
5777725302	Basic valve without coil	ATEX optional	-	Fig. 2
R412003424	-	-	0.72 kg	Fig. 1
5777955280	-	-	0.72 kg	Fig. 1
5777760220	-	-	0.72 kg	Fig. 1
5777765270	-	-	0.72 kg	Fig. 1
5777765280	-	-	0.72 kg	Fig. 1
5777765302	Basic valve without coil	ATEX optional	-	Fig. 1
5777945302	Basic valve without coil	ATEX optional	-	Fig. 1
5777710220	-	-	0.72 kg	Fig. 2
5777715280	-	-	0.72 kg	Fig. 2
5777715302	Basic valve without coil	ATEX optional	-	Fig. 2
5777750220	-	-	0.72 kg	Fig. 1
5777755280	-	-	0.72 kg	Fig. 1
5777755302	Basic valve without coil	ATEX optional	-	Fig. 1
5777700220	-	-	0.72 kg	Fig. 2

Part No.	basic valve with electrical connector	ATEX	Weight	Fig.
5777705302	Basic valve without coil	ATEX optional	-	Fig. 2

Nominal flow Qn at 6 bar and $\Delta p = 1$ bar, MO = Manual override

Technical information

The min. control pressure must be adhered to, since otherwise faulty switching and valve failure may result!
 The pressure dew point must be at least 15 °C under ambient and medium temperature and may not exceed 3 °C .
 The oil content of compressed air must remain constant during the life cycle.
 Use only the approved oils from AVENTICS. Further information can be found in the "Technical information" document (available in the MediaCentre).

ATEX optional: ATEX version can be produced by combining the basic valve without coil with an ATEX coil. ATEX ID: see ATEX coils catalog page.

Technical information

Material	
Housing	Die cast zinc Polyamide fiber-glass reinforced
Seals	Acrylonitrile butadiene rubber

Dimensions

Dimensions, Fig. 1

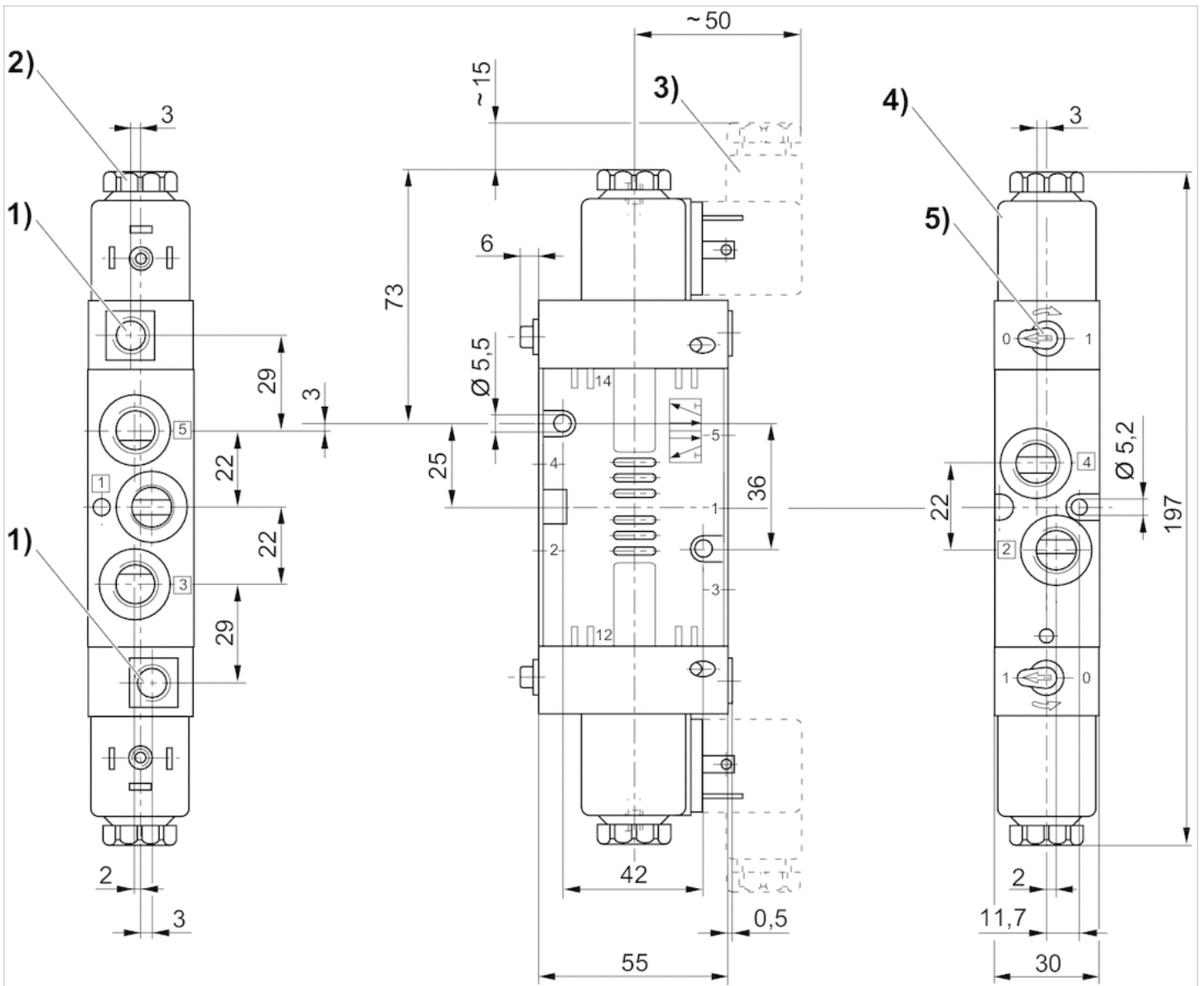

1) Only with separate pilot control G 1/8 2) After removal of cap M5 internal thread 3) Valve plug connector 4) Coil can be plugged at 45° intervals 5) Manual override

Fig. 2

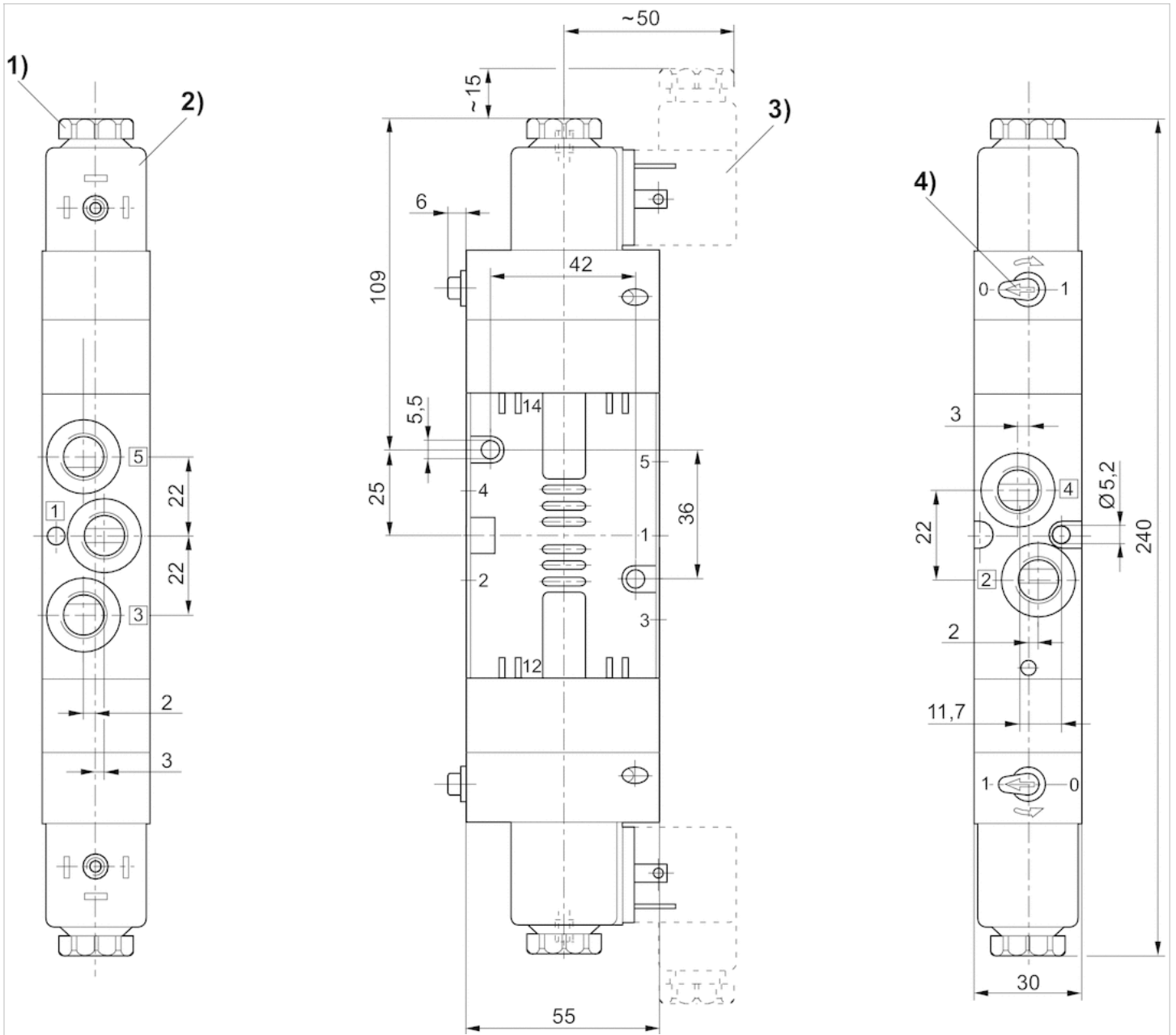

1) After removal of cap M5 internal thread 2) Coil can be plugged at 45° intervals 3) Valve plug connector 4) Manual override

5/3-directional valve, Series CD07

- 5/3
- $Q_n = 900$ l/min
- Pilot valve width : 30 mm
- closed center
- Pipe connection
- Compressed air connection output : M14x1,5
- Electrical connection : Plug, EN 175301-803, form A, 3-pin
- -30 °C cold-resistant
- Manual override : with detent
- double solenoid
- With spring return
- Pilot : Internal

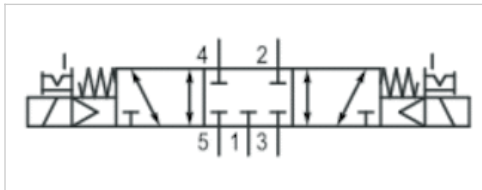

Version	Spool valve, positive overlapping
Activation	Electrically
Pilot	Internal
Sealing principle	Soft sealing
Working pressure min./max.	3.5 ... 10 bar
Control pressure min./max.	3.5 ... 10 bar
Ambient temperature min./max.	-30 ... 70 °C
Medium temperature min./max.	-30 ... 70 °C
Medium	Compressed air
Max. particle size	50 µm
Oil content of compressed air	0 ... 1 mg/m ³
Nominal flow Q_n	900 l/min
Nominal flow 1 ► 2	900 l/min
Nominal flow 2 ► 3	900 l/min
Pilot control exhaust	with directional pilot air exhaust
Connector standard	EN 175301-803:2006
Protection class with connection	IP65
Reverse polarity protection	Protected against polarity reversal
Compatibility index	14
Duty cycle	100 %
Typ. switch-on time	25 ms
Typ. switch-off time	55 ms
Mounting on manifold strip	P-strip PRS strip
Weight	0.72 kg

Technical data

Part No.	MO		Compressed air connection
			Input
5776920270		closed center	M14x1,5

Part No.	Compressed air connection	Compressed air connection
	Output	Exhaust
5776920270	M14x1,5	M14x1,5

Part No.	Compressed air connection	Operational voltage	Voltage tolerance
	Pilot Exhaust	DC	DC
5776920270	M5	110 V	-30% / +30%

Part No.	Power consumption
	DC
5776920270	6 W

Nominal flow Qn at 6 bar and $\Delta p = 1$ bar, MO = Manual override

Technical information

The min. control pressure must be adhered to, since otherwise faulty switching and valve failure may result!

The pressure dew point must be at least 15 °C under ambient and medium temperature and may not exceed 3 °C .

The oil content of compressed air must remain constant during the life cycle.

Use only the approved oils from AVENTICS. Further information can be found in the "Technical information" document (available in the MediaCentre).

Technical information

Material	
Housing	Die cast zinc Polyamide fiber-glass reinforced
Seals	Polyurethane

Dimensions

Dimensions

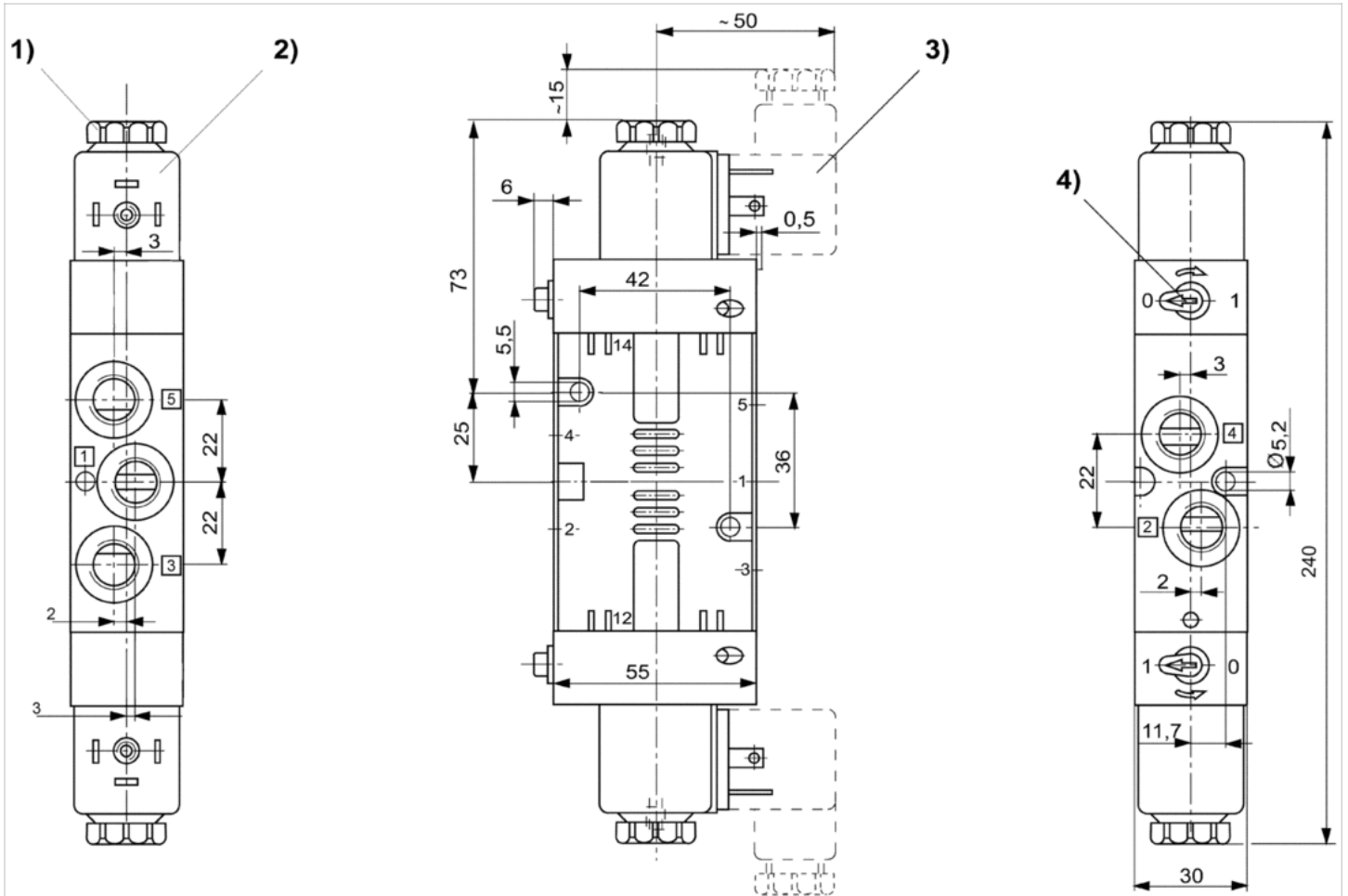

1) After removal of cap M5 internal thread 2) Coil can be plugged at 45° intervals 3) Valve plug connector 4) Manual override







5/2-directional valve, Series CD07

- Valves with Namur port as per VDI/VDE3845
- 5/2
- Qn = 1200 l/min
- Pilot valve width : 30 mm
- Pipe connection
- Compressed air connection output : Namur base plate
- Electrical connection : Plug, EN 175301-803, form A, 3-pin
- -25 °C cold-resistant
- Manual override : with detent
- single solenoid
- With spring return
- Pilot : Internal



Version	Spool valve, positive overlapping
Activation	Electrically
Pilot	Internal
Sealing principle	Soft sealing
Standards	NAMUR
Working pressure min./max.	3 ... 10 bar
Control pressure min./max.	3 ... 10 bar
Ambient temperature min./max.	-25 ... 50 °C
Medium temperature min./max.	-25 ... 50 °C
Medium	Compressed air
Max. particle size	50 µm
Oil content of compressed air	0 ... 1 mg/m ³
Nominal flow Qn	1200 l/min
Nominal flow 1 ► 2	1200 l/min
Nominal flow 2 ► 3	1200 l/min
Compressed air connection	according to ISO 228-1
Pilot control exhaust	with directional pilot air exhaust
Connector standard	EN 175301-803:2006
Reverse polarity protection	Protected against polarity reversal
Compatibility index	13 14
Duty cycle	100 %
Weight	See table below

Technical data

Part No.		MO	Compressed air connection	
			Input	Output
5776600220			G 1/4	Namur base plate
5776605280			G 1/4	Namur base plate
5776605302			G 1/4	Namur base plate

Part No.	Compressed air connection	
	Exhaust	Pilot Exhaust
5776600220	G 1/4	M5
5776605280	G 1/4	M5
5776605302	G 1/4	M5

Part No.	Operational voltage		Operational voltage
	DC	AC 50 Hz	AC 60 Hz
5776600220	24 V	-	-
5776605280	-	230 V	230 V
5776605302	-	-	-

Part No.	Voltage tolerance	Voltage tolerance	Voltage tolerance	Power consumption
	DC	AC 50 Hz	AC 60 Hz	DC
5776600220	-10% / +10%	-	-	2.1 W
5776605280	-	-20% / +10%	-10% / +20%	-
5776605302	-	-	-	-

Part No.	Holding power		Switch-on power	
	AC 50 Hz	AC 60 Hz	AC 50 Hz	AC 60 Hz
5776600220	-	-	-	-
5776605280	4.8 VA	4.1 VA	6.9 VA	5.8 VA
5776605302	-	-	-	-

Part No.	Typ. switch-on time	Typ. switch-off time	Protection class	basic valve with electrical connector
			with connection	
5776600220	25 ms	45 ms	IP65	-
5776605280	25 ms	45 ms	IP65	-
5776605302	-	-	-	Basic valve without coil

Part No.	ATEX	Weight
5776600220	-	0.6 kg
5776605280	-	0.6 kg
5776605302	ATEX optional	-

Nominal flow Q_n at 6 bar and Δp = 1 bar, MO = Manual override

Technical information

The min. control pressure must be adhered to, since otherwise faulty switching and valve failure may result!
 The pressure dew point must be at least 15 °C under ambient and medium temperature and may not exceed 3 °C .
 The oil content of compressed air must remain constant during the life cycle.
 Use only the approved oils from AVENTICS. Further information can be found in the “Technical information” document (available in the MediaCentre).

ATEX optional: ATEX version can be produced by combining the basic valve without coil with an ATEX coil. ATEX ID: see ATEX coils catalog page.

Technical information

Housing	Polyamide fiber-glass reinforced Die cast zinc
---------	--

Dimensions

Dimensions

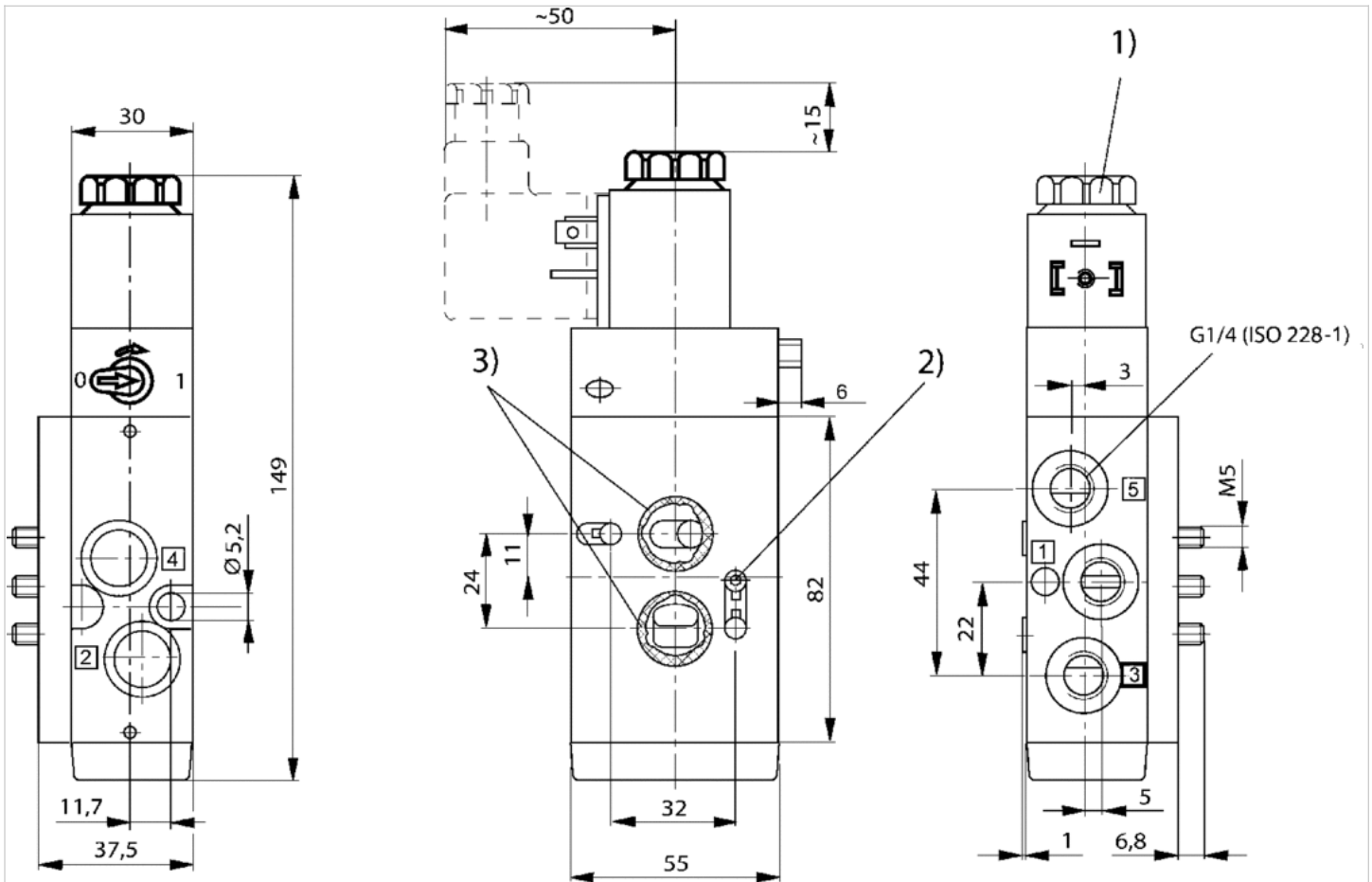

1) after removal of cap M 5 internal thread 2) threaded pin DIN 914 M5 x 20 3) O-ring 16 x 2 (included)







5/2-directional valve, Series CD07

- Valves with Namur port as per VDI/VDE3845
- 5/2
- Qn = 1200 l/min
- Pilot valve width : 30 mm
- Pipe connection
- Compressed air connection output : Namur base plate
- Electrical connection : Plug, EN 175301-803, form A, 3-pin
- -25 °C cold-resistant
- Manual override : with detent
- double solenoid
- Pilot : Internal



Version	Spool valve, positive overlapping
Activation	Electrically
Pilot	Internal
Sealing principle	Soft sealing
Standards	NAMUR
Working pressure min./max.	2 ... 10 bar
Control pressure min./max.	2 ... 10 bar
Ambient temperature min./max.	-25 ... 50 °C
Medium temperature min./max.	-25 ... 50 °C
Medium	Compressed air
Max. particle size	50 µm
Oil content of compressed air	0 ... 1 mg/m ³
Nominal flow Qn	1200 l/min
Nominal flow 1 ► 2	1200 l/min
Nominal flow 2 ► 3	1200 l/min
Compressed air connection	according to ISO 228-1
Pilot control exhaust	with directional pilot air exhaust
Connector standard	EN 175301-803:2006
Reverse polarity protection	Protected against polarity reversal
Compatibility index	13 14
Duty cycle	100 %
Weight	See table below

Technical data

Part No.		MO	Compressed air connection	
			Input	Output
5776620220			G 1/4	Namur base plate
5776625280			G 1/4	Namur base plate
5776625302			G 1/4	Namur base plate

Part No.	Compressed air connection	
	Exhaust	Pilot Exhaust
5776620220	G 1/4	M5
5776625280	G 1/4	M5
5776625302	G 1/4	M5

Part No.	Operational voltage		Operational voltage
	DC	AC 50 Hz	AC 60 Hz
5776620220	24 V	-	-
5776625280	-	230 V	230 V
5776625302	-	-	-

Part No.	Voltage tolerance	Voltage tolerance	Voltage tolerance	Power consumption
	DC	AC 50 Hz	AC 60 Hz	DC
5776620220	-10% / +10%	-	-	2.1 W
5776625280	-	-20% / +10%	-10% / +20%	-
5776625302	-	-	-	-

Part No.	Holding power		Switch-on power	
	AC 50 Hz	AC 60 Hz	AC 50 Hz	AC 60 Hz
5776620220	-	-	-	-
5776625280	4.8 VA	4.1 VA	6.9 VA	5.8 VA
5776625302	-	-	-	-

Part No.	Typ. switch-on time	Typ. switch-off time	Protection class	basic valve with electrical connector
			with connection	
5776620220	21 ms	21 ms	IP65	-
5776625280	21 ms	21 ms	IP65	-
5776625302	-	-	-	Basic valve without coil

Part No.	ATEX	Weight
5776620220	-	0.8 kg
5776625280	-	0.8 kg
5776625302	ATEX optional	-

Nominal flow Q_n at 6 bar and Δp = 1 bar, MO = Manual override

Technical information

The min. control pressure must be adhered to, since otherwise faulty switching and valve failure may result!
 The pressure dew point must be at least 15 °C under ambient and medium temperature and may not exceed 3 °C .
 The oil content of compressed air must remain constant during the life cycle.
 Use only the approved oils from AVENTICS. Further information can be found in the “Technical information” document (available in the MediaCentre).

Technical information

Housing	Die cast zinc Polyamide fiber-glass reinforced
---------	--

Dimensions

Dimensions

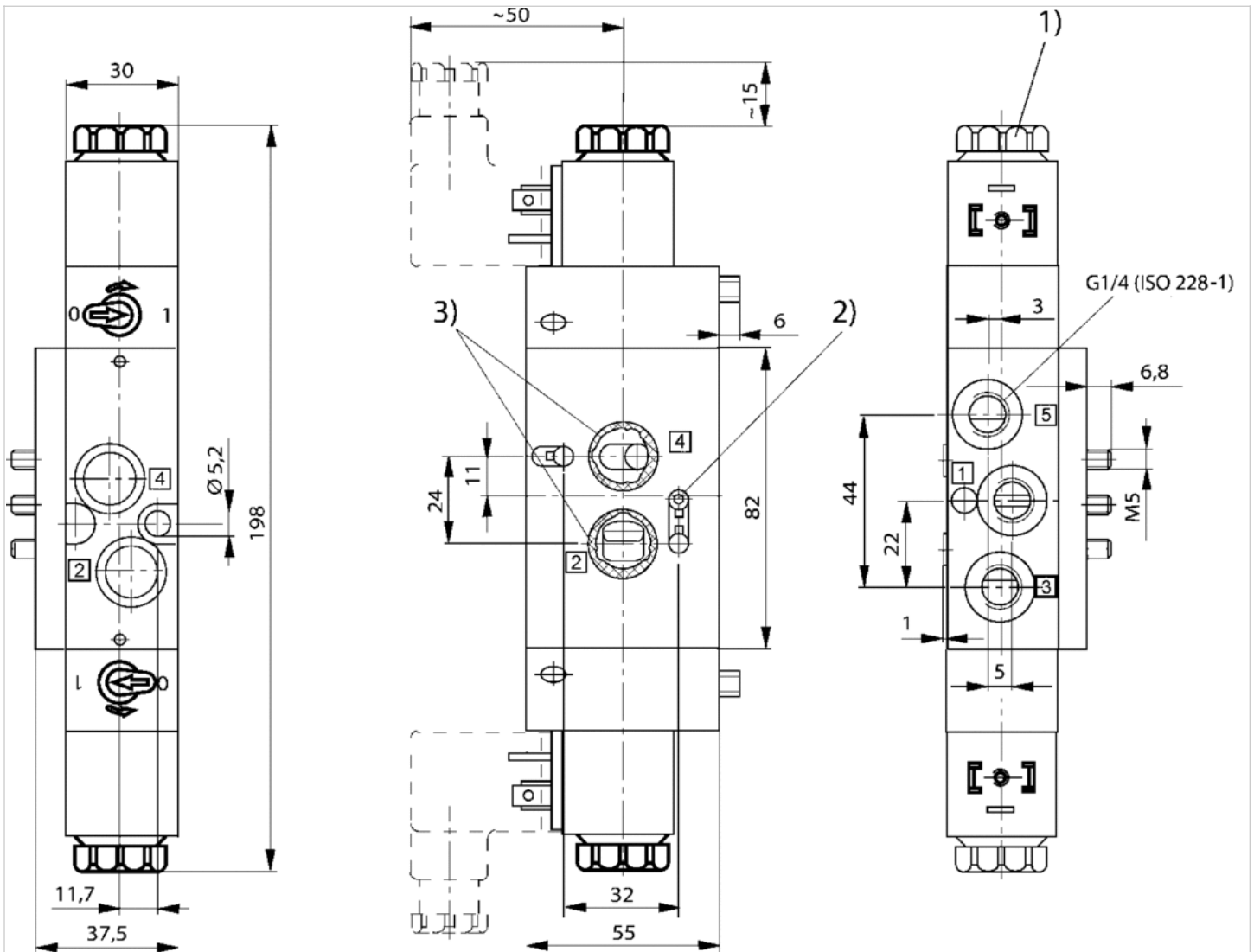

1) after removal of cap M 5 internal thread 2) threaded pin DIN 914 M5 x 20 3) O-ring 16 x 2 (included)

5/3-directional valve, Series CD07

- Valves with Namur port as per VDI/VDE3845
- 5/3
- Qn = 900 l/min
- Pilot valve width : 30 mm
- Pipe connection
- Compressed air connection output : Namur base plate
- Electrical connection : Plug, EN 175301-803, form A, 3-pin
- Manual override : with detent
- double solenoid
- Pilot : Internal
- ATEX optional



Version	Spool valve, positive overlapping
Activation	Electrically
Pilot	Internal
Sealing principle	Soft sealing
Standards	NAMUR
Working pressure min./max.	3 ... 10 bar
Ambient temperature min./max.	0 ... 50 °C
Medium temperature min./max.	0 ... 50 °C
Medium	Compressed air
Max. particle size	50 µm
Oil content of compressed air	0 ... 1 mg/m ³
Nominal flow Qn	900 l/min
Nominal flow 1 ▶ 2	See table below
Nominal flow 2 ▶ 3	See table below
Compressed air connection	according to ISO 228-1
Pilot control exhaust	with directional pilot air exhaust
Connector standard	EN 175301-803:2006
Reverse polarity protection	Protected against polarity reversal
Compatibility index	13 14
Duty cycle	100 %

Technical data

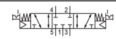
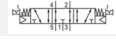
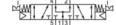
Part No.	MO	Compressed air connection	
		Input	Output
R412011157		G 1/4	Namur base plate
R412011158		G 1/4	Namur base plate
R412011159		G 1/4	Namur base plate

Part No.	Compressed air connection		Nominal flow 1 ▶ 2
	Exhaust	Pilot Exhaust	
R412011157	G 1/4	M5	1070 l/min
R412011158	G 1/4	M5	1030 l/min
R412011159	G 1/4	M5	960 l/min

Part No.	Nominal flow 2 ▶ 3	basic valve with electrical connector	ATEX
R412011157	950 l/min	Basic valve without coil	ATEX optional
R412011158	880 l/min	Basic valve without coil	ATEX optional
R412011159	900 l/min	Basic valve without coil	ATEX optional

Nominal flow Qn at 6 bar and $\Delta p = 1$ bar, MO = Manual override

Technical information

The min. control pressure must be adhered to, since otherwise faulty switching and valve failure may result!

The pressure dew point must be at least 15 °C under ambient and medium temperature and may not exceed 3 °C .

The oil content of compressed air must remain constant during the life cycle.

Use only the approved oils from AVENTICS. Further information can be found in the "Technical information" document (available in the MediaCentre).

Technical information

Material	
Housing	Die cast zinc Polyamide fiber-glass reinforced
Seals	Acrylonitrile butadiene rubber

Dimensions

Dimensions

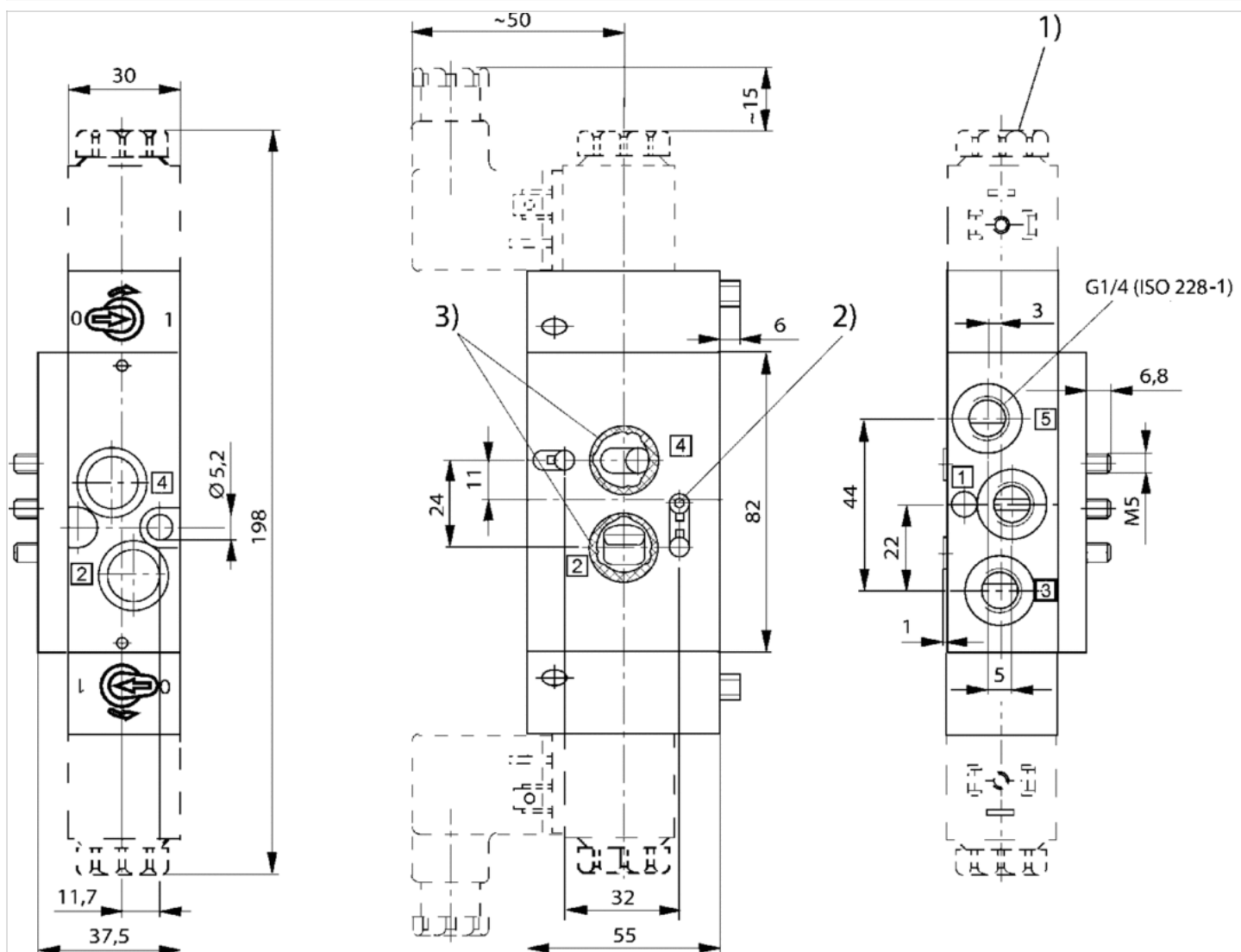

1) after removal of cap M 5 internal thread 2) threaded pin DIN 914 M5 x 20 3) O-ring 16 x 2 (included)

2/2-directional valve, Series CD07

- Qn = 1400 l/min
- Qn 1►2 = 1400 l/min
- Compressed air connection output M14x1,5
- Single air pilot, double air pilot
- Pipe connection
- suitable for ATEX



Version	Spool valve, positive overlapping
Activation	pneumatically
Sealing principle	Soft sealing
Flow rate value Qn	1400 l/min
Flow rate value Qn 1►2	1400 l/min
Working pressure min./max.	-0.95 ... 10 bar
Control pressure min./max.	2.5 ... 10 bar
Ambient temperature min./max.	-25 ... 80 °C
Medium temperature min./max.	-25 ... 80 °C
Medium	Compressed air
Max. particle size	50 µm
Oil content of compressed air	0 ... 1 mg/m ³
Weight	0.4 kg

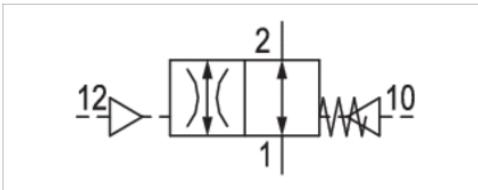

Technical data

Part No.		Compressed air connection	
		Input	Output
5710409000	NO	M14x1,5	M14x1,5

Part No.	Compressed air connection	
	Pilot control exhaust	
5710409000	M10x1 M16x1	

Nominal flow Qn at 6 bar and $\Delta p = 1$ bar, Nominal flow Qn (1►2) can be throttled up to 100 l/min .

Technical information

The min. control pressure must be adhered to, since otherwise faulty switching and valve failure may result!
 The pressure dew point must be at least 15 °C under ambient and medium temperature and may not exceed 3 °C .
 The oil content of compressed air must remain constant during the life cycle.
 Use only the approved oils from AVENTICS. Further information can be found in the "Technical information" document (available in the MediaCentre).

Technical information

Housing	Die cast zinc
---------	---------------

Dimensions

Dimensions

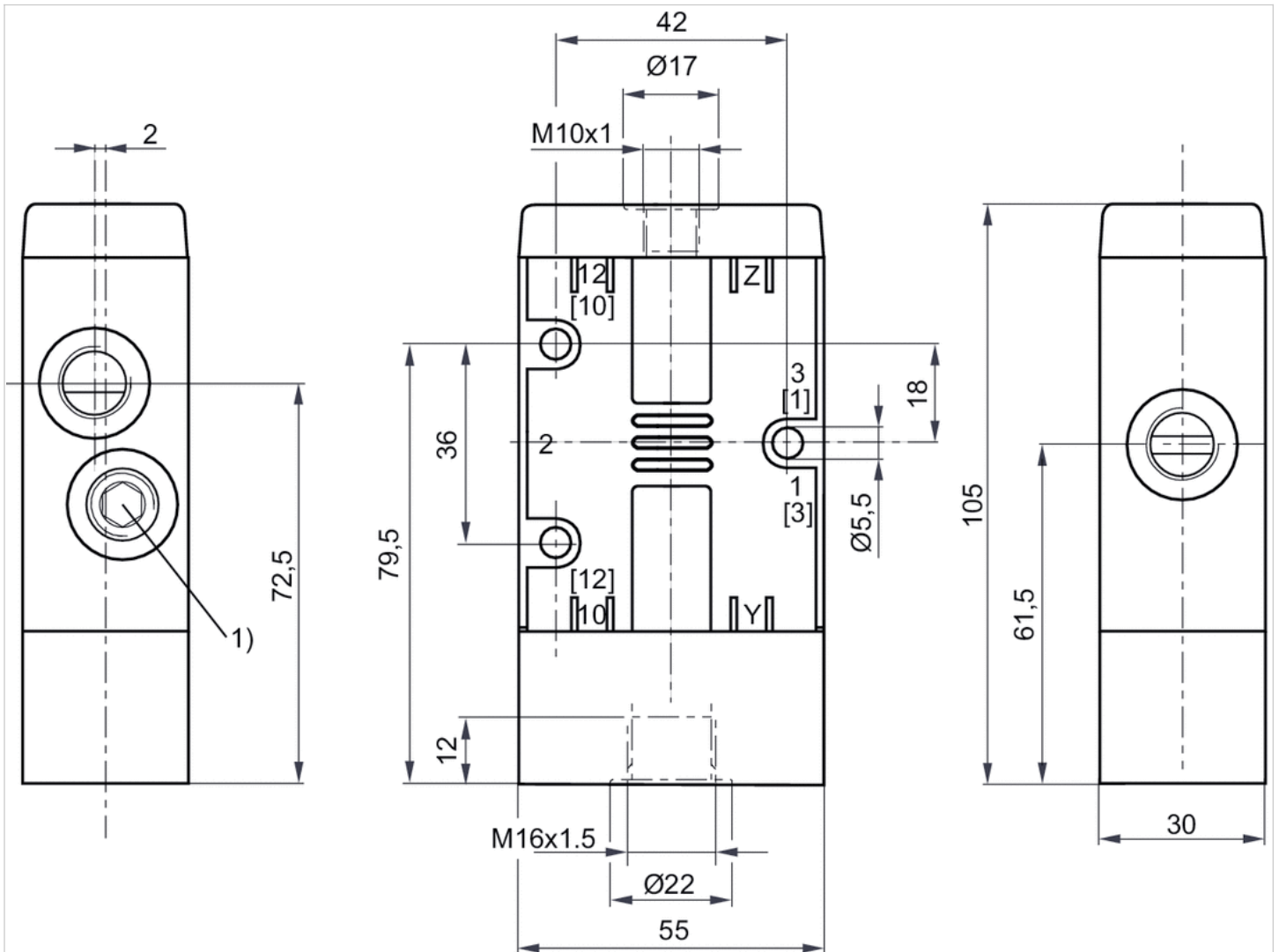

1) Blanking screw



3/2-directional valve, Series CD07

- Qn = 1400 l/min
- Compressed air connection output G 1/4
- Pipe connection
- suitable for ATEX



Version	Spool valve, positive overlapping
Activation	pneumatically
Sealing principle	Soft sealing
Flow rate value Qn	1400 l/min
Working pressure min./max.	-0.95 ... 10 bar
Control pressure min./max.	See table below
Ambient temperature min./max.	-25 ... 80 °C
Medium temperature min./max.	-25 ... 80 °C
Medium	Compressed air
Max. particle size	50 µm
Oil content of compressed air	0 ... 1 mg/m ³
Weight	0.4 kg

Technical data

Part No.			Compressed air connection	
			Input	Output
5710400100		NC/NO	G 1/4	G 1/4
5710401100		NC/NO	G 1/4	G 1/4

Part No.	Compressed air connection		Control pressure min./max.
	Exhaust	Pilot control exhaust	
5710400100	G 1/4	G 1/8	3 ... 10 bar
5710401100	G 1/4	G 1/8	2 ... 10 bar

Nominal flow Qn at 6 bar and $\Delta p = 1$ bar

Technical information

The min. control pressure must be adhered to, since otherwise faulty switching and valve failure may result!
 The pressure dew point must be at least 15 °C under ambient and medium temperature and may not exceed 3 °C .
 The oil content of compressed air must remain constant during the life cycle.
 Use only the approved oils from AVENTICS. Further information can be found in the "Technical information" document (available in the MediaCentre).

option valve: The input and output compressed air connections can be exchanged.
 The valve can thereby be used in the NC or NO operating mode.

Technical information

Material	
Housing	Die cast zinc
Seals	Acrylonitrile butadiene rubber

Dimensions

Dimensions

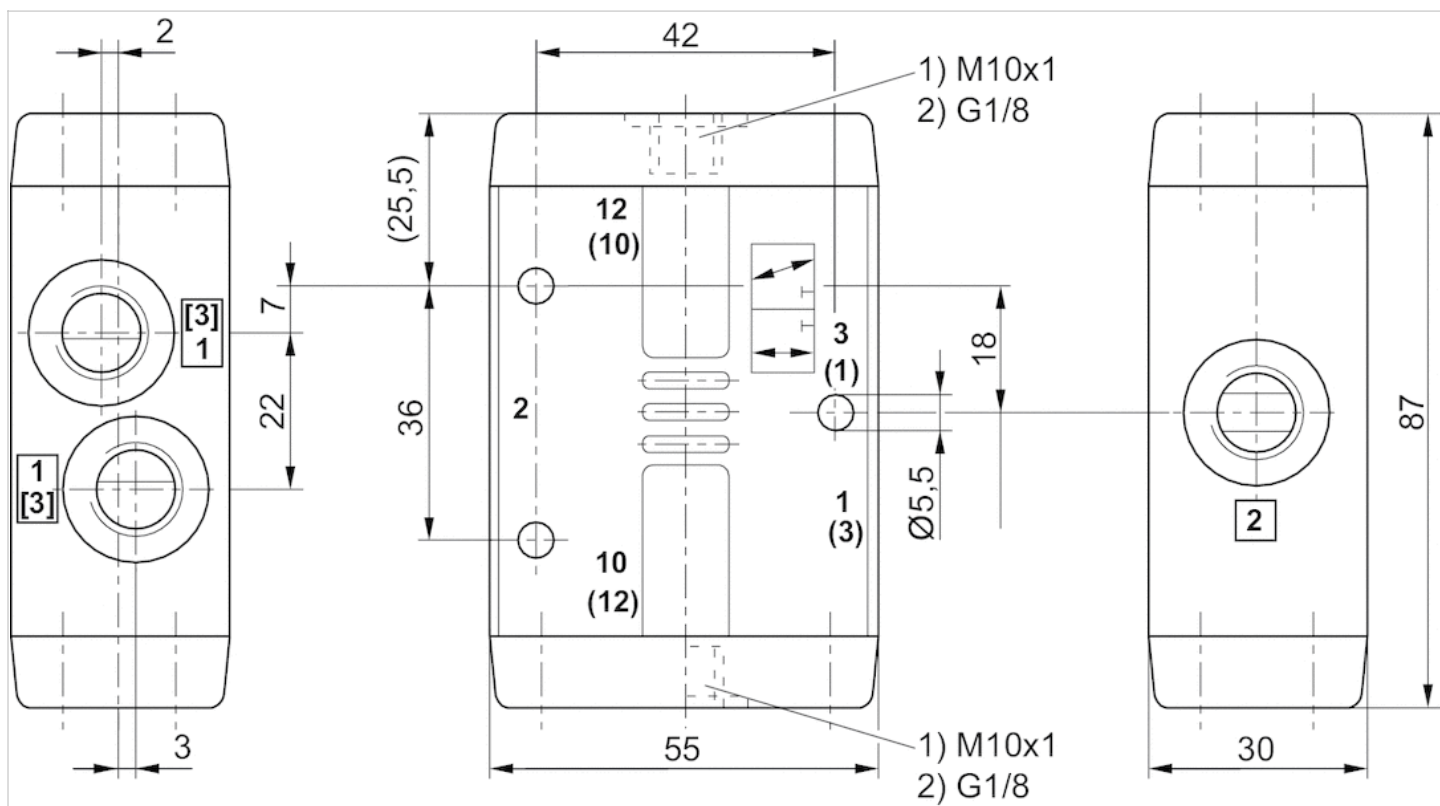



3/2-directional valve, Series CD07

- Qn = 1400 l/min
- Compressed air connection output M14x1,5
- Pipe connection
- suitable for ATEX



Version	Spool valve, positive overlapping
Activation	pneumatically
Sealing principle	Soft sealing
Flow rate value Qn	1400 l/min
Working pressure min./max.	-0.95 ... 10 bar
Control pressure min./max.	See table below
Ambient temperature min./max.	See table below
Medium temperature min./max.	See table below
Medium	Compressed air
Max. particle size	50 µm
Oil content of compressed air	0 ... 1 mg/m ³
Weight	0.4 kg

Technical data

Part No.			Compressed air connection	
			Input	Output
5710400000		NC/NO	M14x1,5	M14x1,5
5710400090		NC/NO	M14x1,5	M14x1,5
5710401000		NC/NO	M14x1,5	M14x1,5

Part No.	Compressed air connection		Control pressure min./max.
	Exhaust	Pilot control exhaust	
5710400000	M14x1,5	M10x1	3 ... 10 bar
5710400090	M14x1,5	M10x1	4 ... 10 bar
5710401000	M14x1,5	M10x1	2 ... 10 bar

Part No.	Ambient temperature min./max.	Medium temperature min./max.	
5710400000	-25 ... 80 °C	-25 ... 80 °C	-
5710400090	-35 ... 80 °C	-35 ... 80 °C	1)
5710401000	-25 ... 80 °C	-25 ... 80 °C	-

Nominal flow Qn at 6 bar and $\Delta p = 1$ bar

1) -30 °C cold-resistant

Technical information

The min. control pressure must be adhered to, since otherwise faulty switching and valve failure may result!

The pressure dew point must be at least 15 °C under ambient and medium temperature and may not exceed 3 °C .

The oil content of compressed air must remain constant during the life cycle.

Use only the approved oils from AVENTICS. Further information can be found in the "Technical information" document (available in the MediaCentre).

option valve: The input and output compressed air connections can be exchanged.

The valve can thereby be used in the NC or NO operating mode.

Technical information

Housing	Die cast zinc
---------	---------------

Dimensions

Dimensions

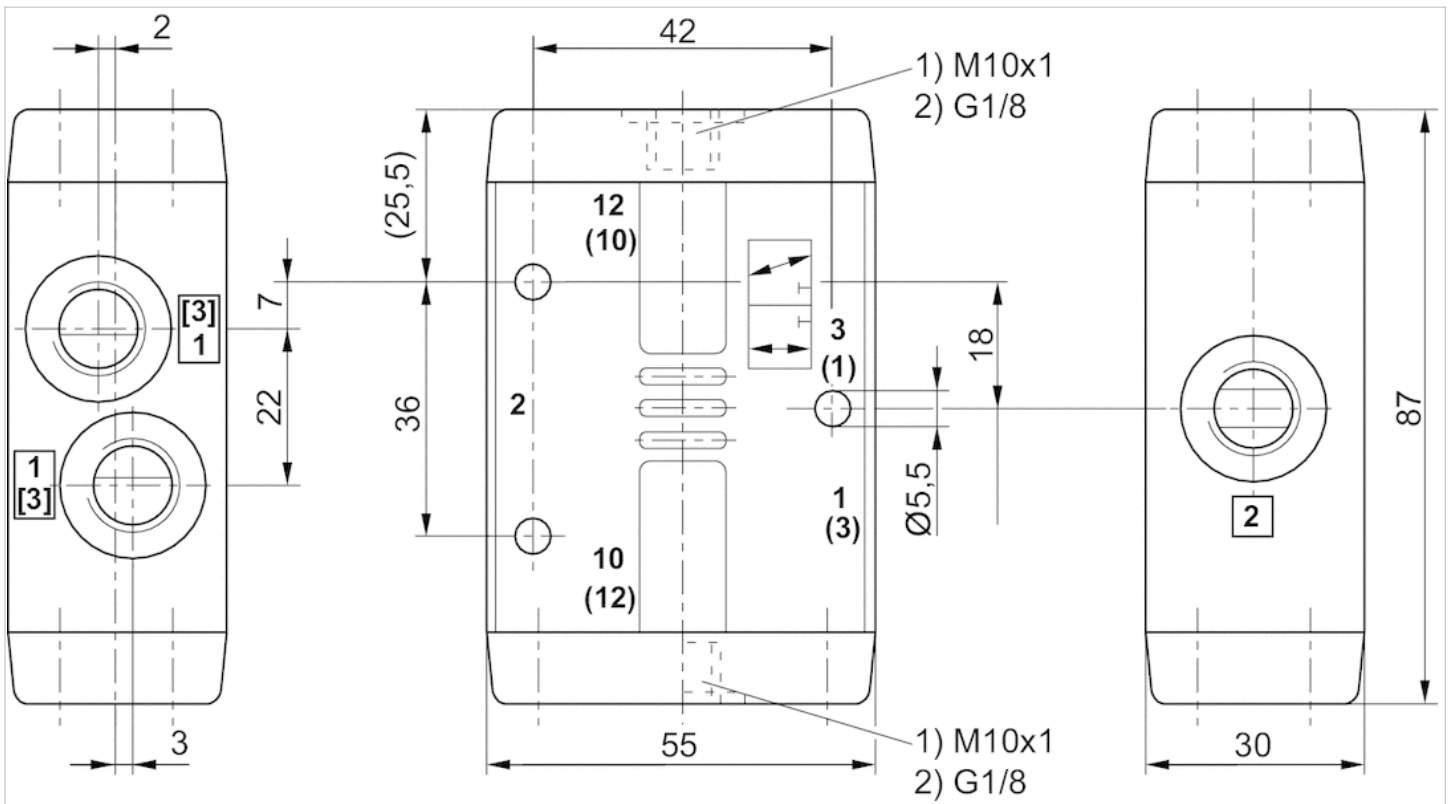



5/2-directional valve, Series CD07

- Qn = 1200 l/min
- Compressed air connection output G 1/4
- Pipe connection
- suitable for ATEX



Version	Spool valve, positive overlapping
Activation	pneumatically
Sealing principle	Soft sealing
Compressed air connection	according to ISO 228-1
Flow rate value Qn	1200 l/min
Working pressure min./max.	-0.95 ... 10 bar
Control pressure min./max.	See table below
Ambient temperature min./max.	-25 ... 80 °C
Medium temperature min./max.	-25 ... 80 °C
Medium	Compressed air
Max. particle size	50 µm
Oil content of compressed air	0 ... 1 mg/m ³
Mounting on manifold strip	P-strip PRS strip
Weight	0.5 kg

Technical data

Part No.		Compressed air connection	
		Input	Output
5710500100		G 1/4	G 1/4
5710501100		G 1/4	G 1/4

Part No.	Compressed air connection		Control pressure min./max.
	Exhaust	Pilot control exhaust	
5710500100	G 1/4	G 1/8	3 ... 10 bar
5710501100	G 1/4	G 1/8	2 ... 10 bar

Nominal flow Qn at 6 bar and $\Delta p = 1$ bar, Protected against dust

Technical information

The min. control pressure must be adhered to, since otherwise faulty switching and valve failure may result!
 The pressure dew point must be at least 15 °C under ambient and medium temperature and may not exceed 3 °C .
 The oil content of compressed air must remain constant during the life cycle.
 Use only the approved oils from AVENTICS. Further information can be found in the "Technical information" document (available in the MediaCentre).

Technical information

Material	
Housing	Die cast zinc
Seals	Acrylonitrile butadiene rubber

Dimensions

Dimensions

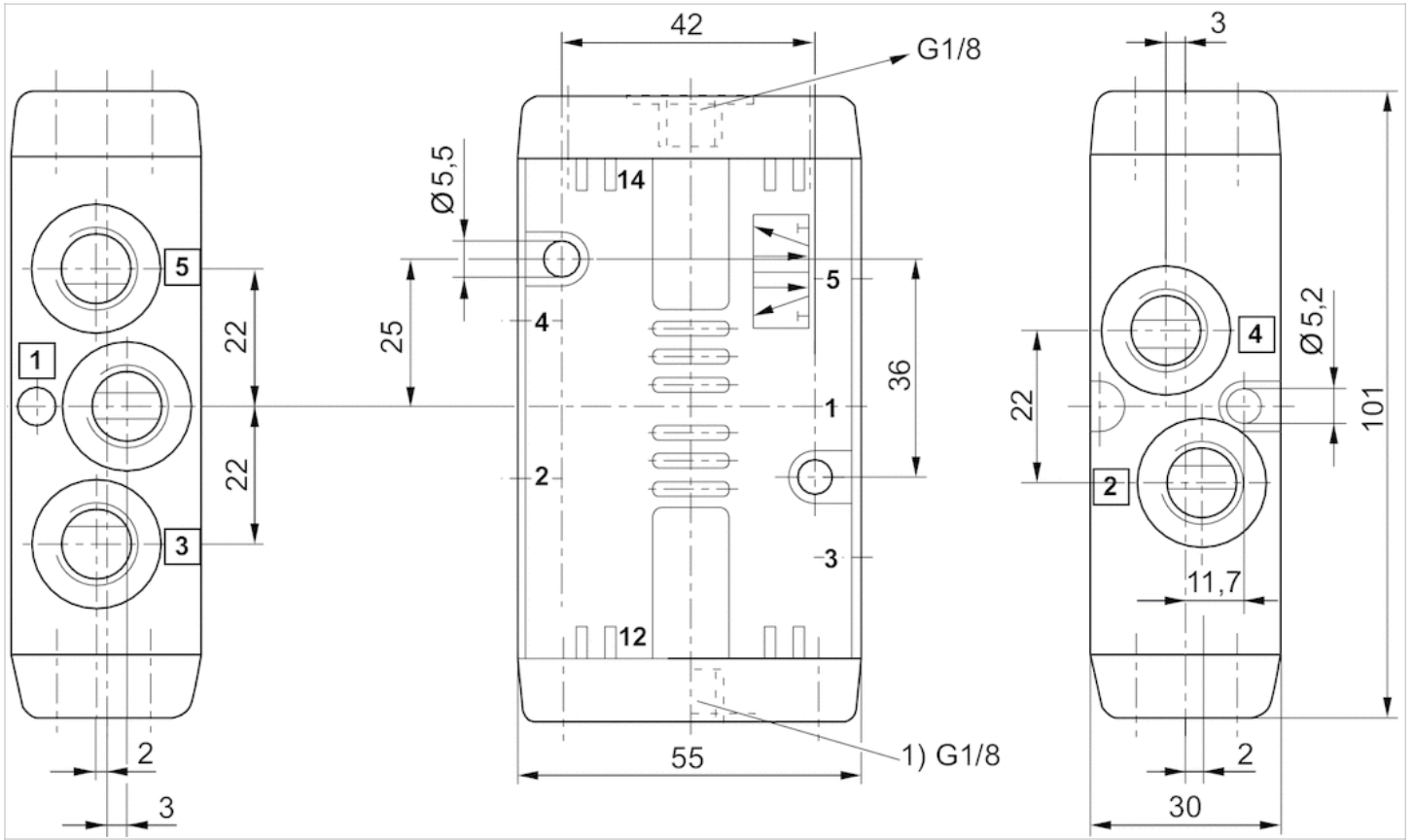

1) Part No.: 5710501100



5/2-directional valve, Series CD07

- Qn = 1200 l/min
- Compressed air connection output M14x1,5
- Pipe connection
- suitable for ATEX



Version	Spool valve, positive overlapping
Activation	pneumatically
Sealing principle	Soft sealing
Flow rate value Qn	1200 l/min
Working pressure min./max.	-0.95 ... 10 bar
Control pressure min./max.	See table below
Ambient temperature min./max.	-25 ... 80 °C
Medium temperature min./max.	-25 ... 80 °C
Medium	Compressed air
Max. particle size	50 µm
Oil content of compressed air	0 ... 1 mg/m ³
Mounting on manifold strip	P-strip PRS strip
Weight	0.5 kg

Technical data

Part No.		Compressed air connection	
		Input	Output
5710500000		M14x1,5	M14x1,5
5710509300		M14x1,5	M14x1,5
5710501000		M14x1,5	M14x1,5

Part No.	Compressed air connection		Control pressure min./max.
	Exhaust	Pilot control exhaust	
5710500000	M14x1,5	M10x1	3 ... 10 bar
5710509300	M14x1,5	M10x1	3 ... 10 bar
5710501000	M14x1,5	M10x1	2 ... 10 bar

Part No.	Part No.
5710500000	-
5710509300	1)
5710501000	-

Nominal flow Qn at 6 bar and $\Delta p = 1$ bar

1) Protected against dust

Technical information

The min. control pressure must be adhered to, since otherwise faulty switching and valve failure may result!

The pressure dew point must be at least 15 °C under ambient and medium temperature and may not exceed 3 °C .

The oil content of compressed air must remain constant during the life cycle.

Use only the approved oils from AVENTICS. Further information can be found in the "Technical information" document (available in the MediaCentre).

Technical information

Housing	Die cast zinc
---------	---------------

Dimensions

Dimensions

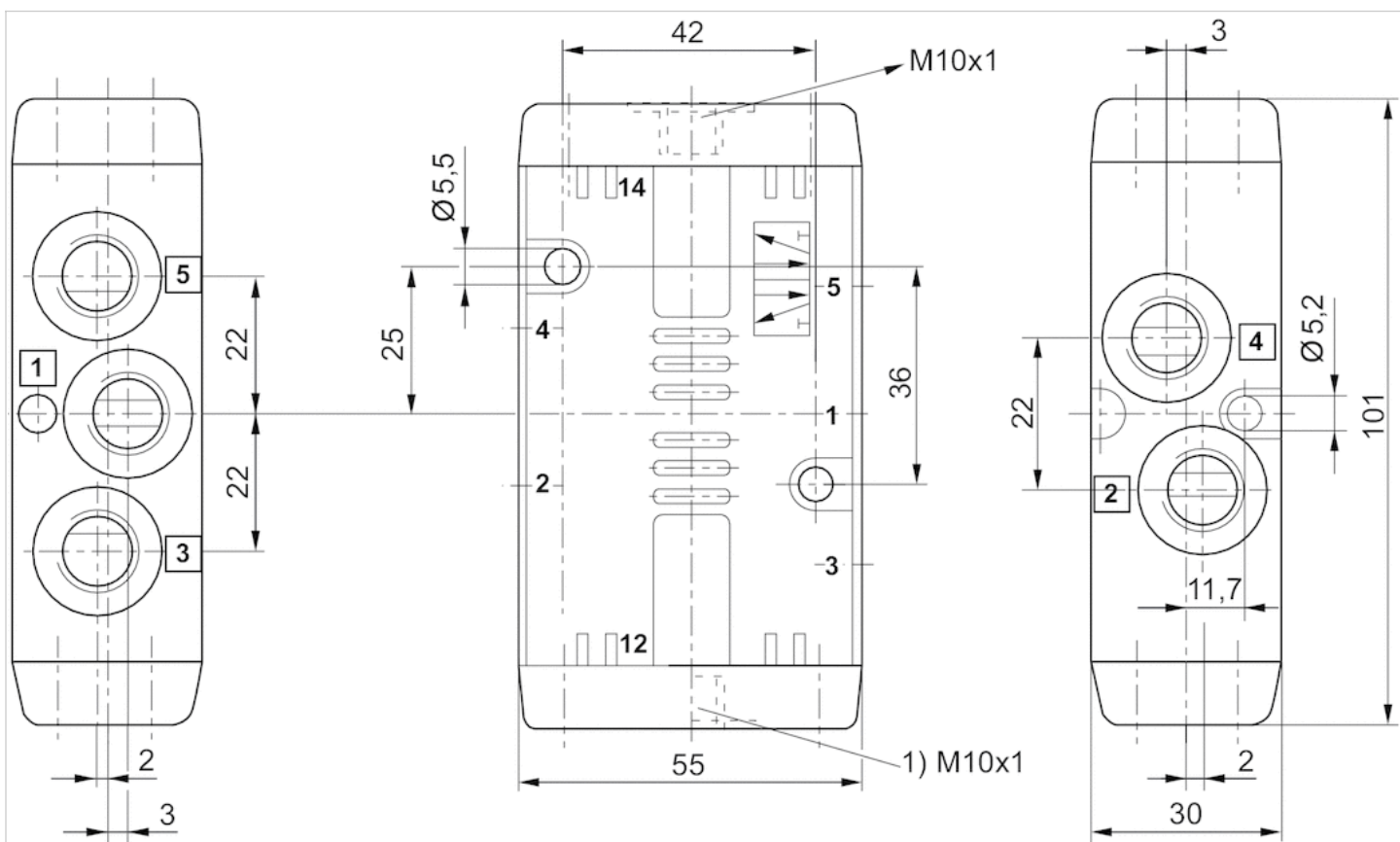

1) Part No.: 5710501000



5/2-directional valve, Series CD07

- Qn = 1200 l/min
- Compressed air connection output G 1/4
- Pipe connection
- -40 °C cold-resistant
- suitable for ATEX



Version	Spool valve, positive overlapping
Activation	pneumatically
Sealing principle	Soft sealing
Compressed air connection	according to ISO 228-1
Flow rate value Qn	1200 l/min
Working pressure min./max.	-0.95 ... 10 bar
Control pressure min./max.	See table below
Ambient temperature min./max.	-40 ... 70 °C
Medium temperature min./max.	-40 ... 70 °C
Medium	Compressed air
Max. particle size	50 µm
Oil content of compressed air	0 ... 1 mg/m ³
Mounting on manifold strip	P-strip PRS strip
Weight	0.5 kg

Technical data

Part No.		Compressed air connection	
		Input	Output
5710500190		G 1/4	G 1/4
5710501190		G 1/4	G 1/4

Part No.	Compressed air connection		Control pressure min./max.
	Exhaust	Pilot control exhaust	
5710500190	G 1/4	G 1/8	3.5 ... 10 bar
5710501190	G 1/4	G 1/8	3 ... 10 bar

Nominal flow Qn at 6 bar and $\Delta p = 1$ bar

Technical information

The min. control pressure must be adhered to, since otherwise faulty switching and valve failure may result!
 The pressure dew point must be at least 15 °C under ambient and medium temperature and may not exceed 3 °C .
 The oil content of compressed air must remain constant during the life cycle.
 Use only the approved oils from AVENTICS. Further information can be found in the "Technical information" document (available in the MediaCentre).

Technical information

Material	
Housing	Die cast zinc
Seals	Acrylonitrile butadiene rubber Polyurethane

Dimensions

Dimensions

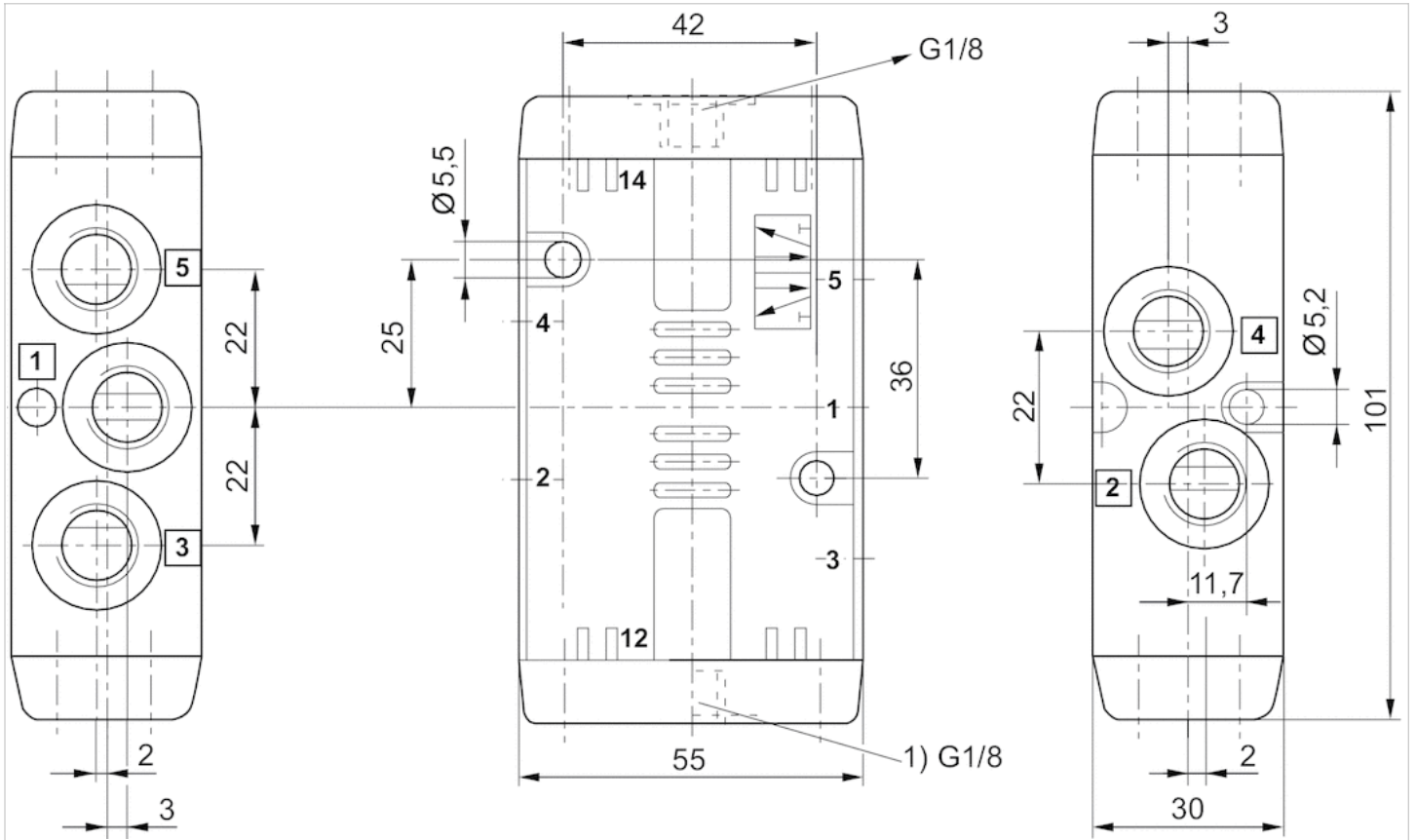

1) Part No.: 5710501190



5/3-directional valve, Series CD07

- Qn = 900 l/min
- Qn 1►2 = 960-1070 l/min
- Qn 2►3 = 880-950 l/min
- Compressed air connection output G 1/4
- double air pilot
- Pipe connection
- suitable for ATEX



Version	Spool valve, positive overlapping
Activation	pneumatically
Sealing principle	Soft sealing
Compressed air connection	according to ISO 228-1
Flow rate value Qn	900 l/min
Working pressure min./max.	-0.95 ... 10 bar
Control pressure min./max.	3 ... 10 bar
Ambient temperature min./max.	-25 ... 80 °C
Medium temperature min./max.	-25 ... 80 °C
Medium	Compressed air
Max. particle size	50 µm
Oil content of compressed air	0 ... 1 mg/m ³
Mounting on manifold strip	P-strip PRS strip
Weight	1.15 kg

Technical data

Part No.			Compressed air connection	
				Input
5710502100		pressurized center		G 1/4
5710502110		exhausted center		G 1/4
5710502120		closed center		G 1/4

Part No.	Compressed air connection	
	Output	Exhaust
5710502100	G 1/4	G 1/4
5710502110	G 1/4	G 1/4
5710502120	G 1/4	G 1/4

Part No.	Compressed air connection		Flow	Flow
	Pilot control exhaust		Qn 1►2	Qn 2►3
5710502100	G 1/8		960 l/min	-
5710502110	G 1/8		1030 l/min	880 l/min
5710502120	G 1/8		1070 l/min	950 l/min

Nominal flow Qn at 6 bar and $\Delta p = 1$ bar

Technical information

The min. control pressure must be adhered to, since otherwise faulty switching and valve failure may result!
 The pressure dew point must be at least 15 °C under ambient and medium temperature and may not exceed 3 °C .
 The oil content of compressed air must remain constant during the life cycle.
 Use only the approved oils from AVENTICS. Further information can be found in the “Technical information” document (available in the MediaCentre).

Technical information

Housing	Die cast zinc Polyamide fiber-glass reinforced
---------	--

Dimensions

Dimensions

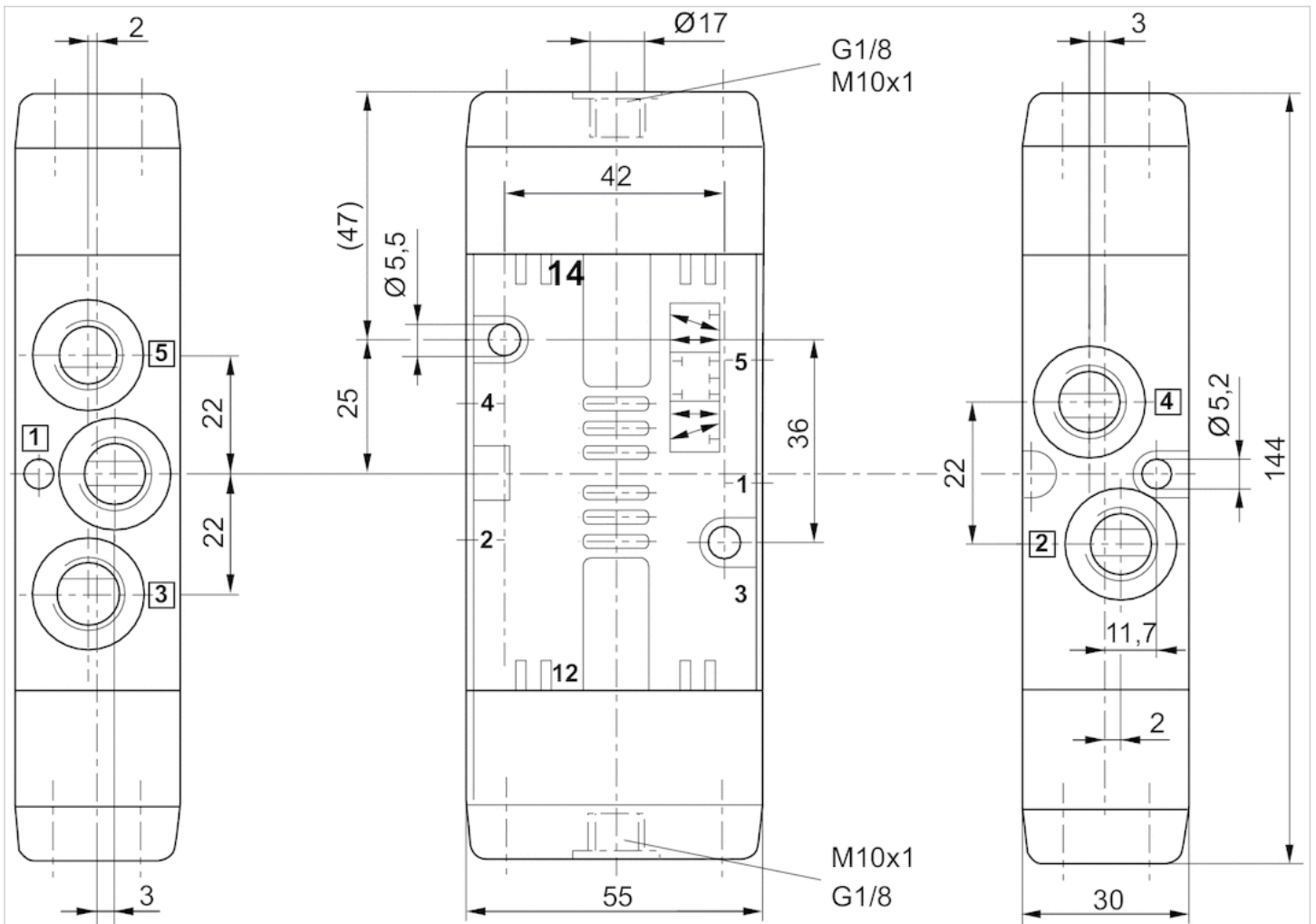

5/3-directional valve, Series CD07

- Qn 1►2 = 960 l/min
- Qn 2►3 = 900 l/min
- Compressed air connection output M14x1,5
- double air pilot
- Pipe connection
- suitable for ATEX

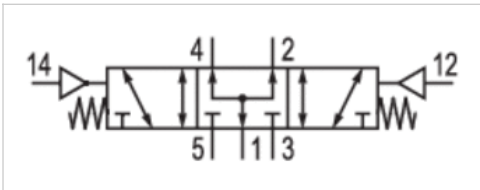

Version	Spool valve, positive overlapping
Activation	pneumatically
Sealing principle	Soft sealing
Flow rate value Qn 1►2	960 l/min
Flow rate value Qn 2►3	900 l/min
Working pressure min./max.	-0.95 ... 10 bar
Control pressure min./max.	3 ... 10 bar
Ambient temperature min./max.	-25 ... 80 °C
Medium temperature min./max.	-25 ... 80 °C
Medium	Compressed air
Max. particle size	50 µm
Oil content of compressed air	0 ... 1 mg/m ³
Mounting on manifold strip	P-strip PRS strip
Weight	1.15 kg

Technical data

Part No.	Compressed air connection	
	Input	Output
R412008118	M14x1,5	M14x1,5

Part No.	Compressed air connection	
	Exhaust	Pilot control exhaust
R412008118	M14x1,5	M10x1

Nominal flow Qn at 6 bar and $\Delta p = 1$ bar

Technical information

The min. control pressure must be adhered to, since otherwise faulty switching and valve failure may result!
 The pressure dew point must be at least 15 °C under ambient and medium temperature and may not exceed 3 °C .
 The oil content of compressed air must remain constant during the life cycle.
 Use only the approved oils from AVENTICS. Further information can be found in the "Technical information" document (available in the MediaCentre).

Technical information

Housing	Die cast zinc Polyamide fiber-glass reinforced
---------	--

Dimensions

Dimensions

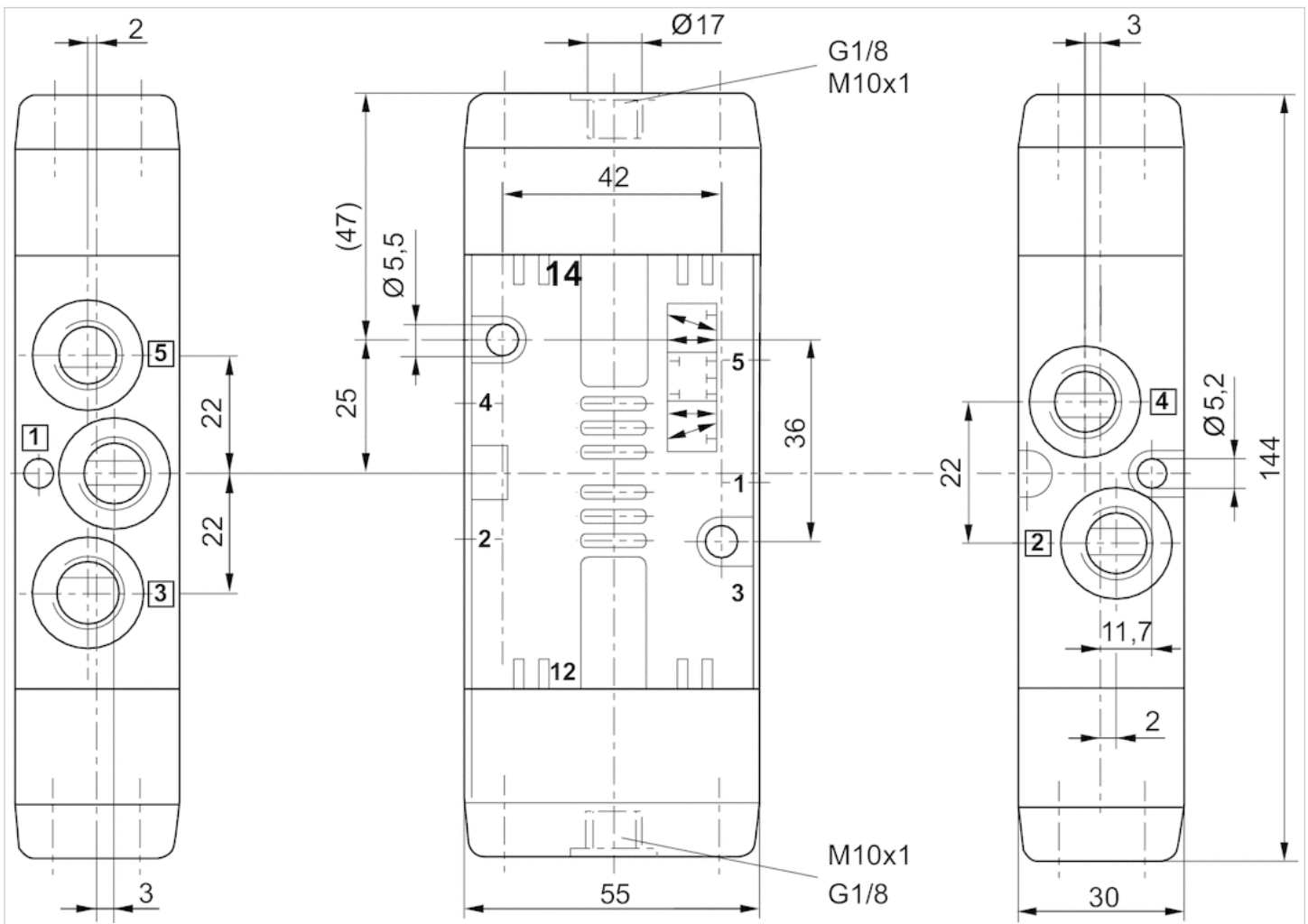









3/2-directional valve, Series CD07

- Qn = 1400 l/min
- Compressed air connection output G 1/4
- Pipe connection
- suitable for ATEX



Version	Spool valve, positive overlapping
Activation	Mechanical
Switching principle	3/2
Sealing principle	Soft sealing
Nominal flow Qn	1400 l/min
Working pressure min./max.	-0.95 ... 10 bar
Control pressure min./max.	See table below
Ambient temperature min./max.	-25 ... 80 °C
Medium temperature min./max.	-25 ... 80 °C
Medium	Compressed air
Oil content of compressed air	0 ... 1 mg/m ³
Weight	See table below

Technical data

Part No.		Actuating element	Version	Compressed air connection type
5634400100		Plunger	NC/NO	Internal thread
5634409010		Plunger	NC/NO	-
5634410100		Roller	NC/NO	Internal thread
5634411100		Roller	NC/NO	-
5634430100		Hand lever, with detent, without detent	NC/NO	Internal thread
5634440100		Hand lever	NC/NO	Internal thread
5634450100		Lever, horizontal, with detent	NC/NO	Internal thread
5634460100		Button	NC/NO	Internal thread
5634461100		Button	NC/NO	Internal thread

Part No.	Compressed air connection Input	Compressed air connection Output	Compressed air connection Exhaust
5634400100	G 1/4	G 1/4	G 1/4
5634409010	G 1/4	G 1/4	G 1/4
5634410100	G 1/4	G 1/4	G 1/4
5634411100	G 1/4	G 1/4	G 1/4
5634430100	G 1/4	G 1/4	G 1/4
5634440100	G 1/4	G 1/4	G 1/4
5634450100	G 1/4	G 1/4	G 1/4
5634460100	G 1/4	G 1/4	G 1/4
5634461100	G 1/4	G 1/4	G 1/4

Part No.	Compressed air connection Pilot control exhaust	Operating force	Control pressure min./max.
		min.	
5634400100	-	70 N	-
5634409010	-	40 N	-
5634410100	-	40 N	-

Part No.	Compressed air connection Pilot control exhaust	Operating force	Control pressure min./max.
		min.	
5634411100	G 1/8	40 N	2 ... 10 bar
5634430100	-	20 N	-
5634440100	-	15 N	-
5634450100	-	15 N	-
5634460100	-	70 N	-
5634461100	G 1/8	40 N	2 ... 10 bar

Part No.	Housing material	Material actuating control	Weight
5634400100	Die cast zinc Polyamide fiber-glass reinforced	Stainless steel	0.45 kg
5634409010	Die cast zinc	Stainless steel	0.45 kg
5634410100	Die cast zinc Polyamide fiber-glass reinforced	Stainless steel	0.5 kg
5634411100	Die cast zinc	Stainless steel	0.5 kg
5634430100	Die cast zinc Polyamide fiber-glass reinforced	Polyoxymethylene	0.53 kg
5634440100	Die cast zinc Polyamide fiber-glass reinforced	Polyoxymethylene	0.5 kg
5634450100	Die cast zinc Polyamide fiber-glass reinforced	Polyoxymethylene	0.55 kg
5634460100	Die cast zinc Polyamide fiber-glass reinforced	Polyoxymethylene	0.45 kg
5634461100	Die cast zinc Polyamide fiber-glass reinforced	Polyoxymethylene	0.45 kg

Part No.	Fig.
5634400100	Fig. 1
5634409010	Fig. 2
5634410100	Fig. 3
5634411100	Fig. 4
5634430100	Fig. 5
5634440100	Fig. 6
5634450100	Fig. 7
5634460100	Fig. 8
5634461100	Fig. 8

Nominal flow Q_n at 6 bar and $\Delta p = 1$ bar

Technical information

option valve: The input and output compressed air connections can be exchanged.
The valve can thereby be used in the NC or NO operating mode.

Technical information

Material	
Housing	Die cast zinc Polyamide fiber-glass reinforced Die cast zinc
Seals	Acrylonitrile butadiene rubber
Actuating element	Stainless steel Polyoxymethylene

Dimensions

Dimensions, Fig. 1

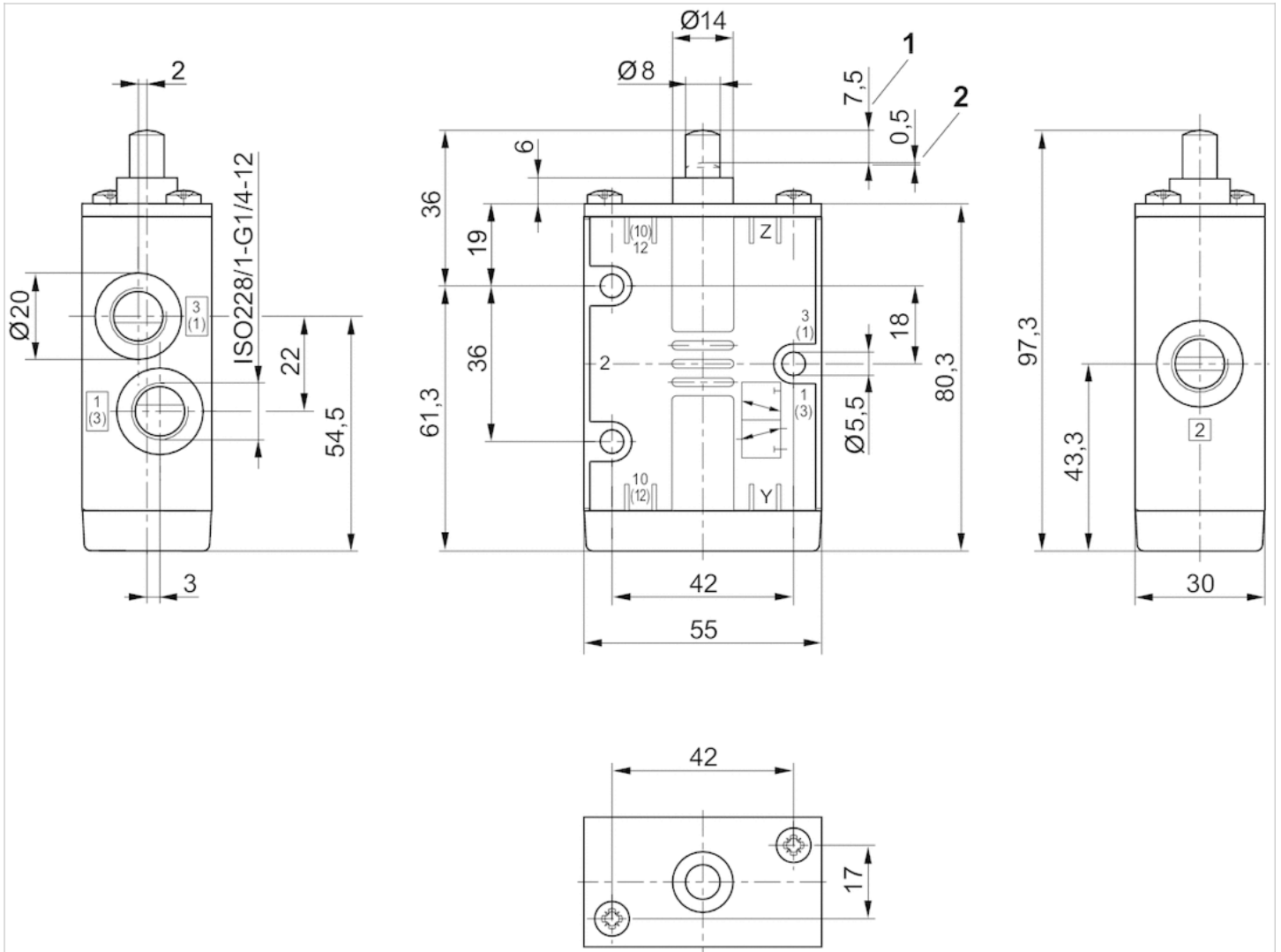

1) Stroke 2) Overstroke

Dimensions, Fig. 2

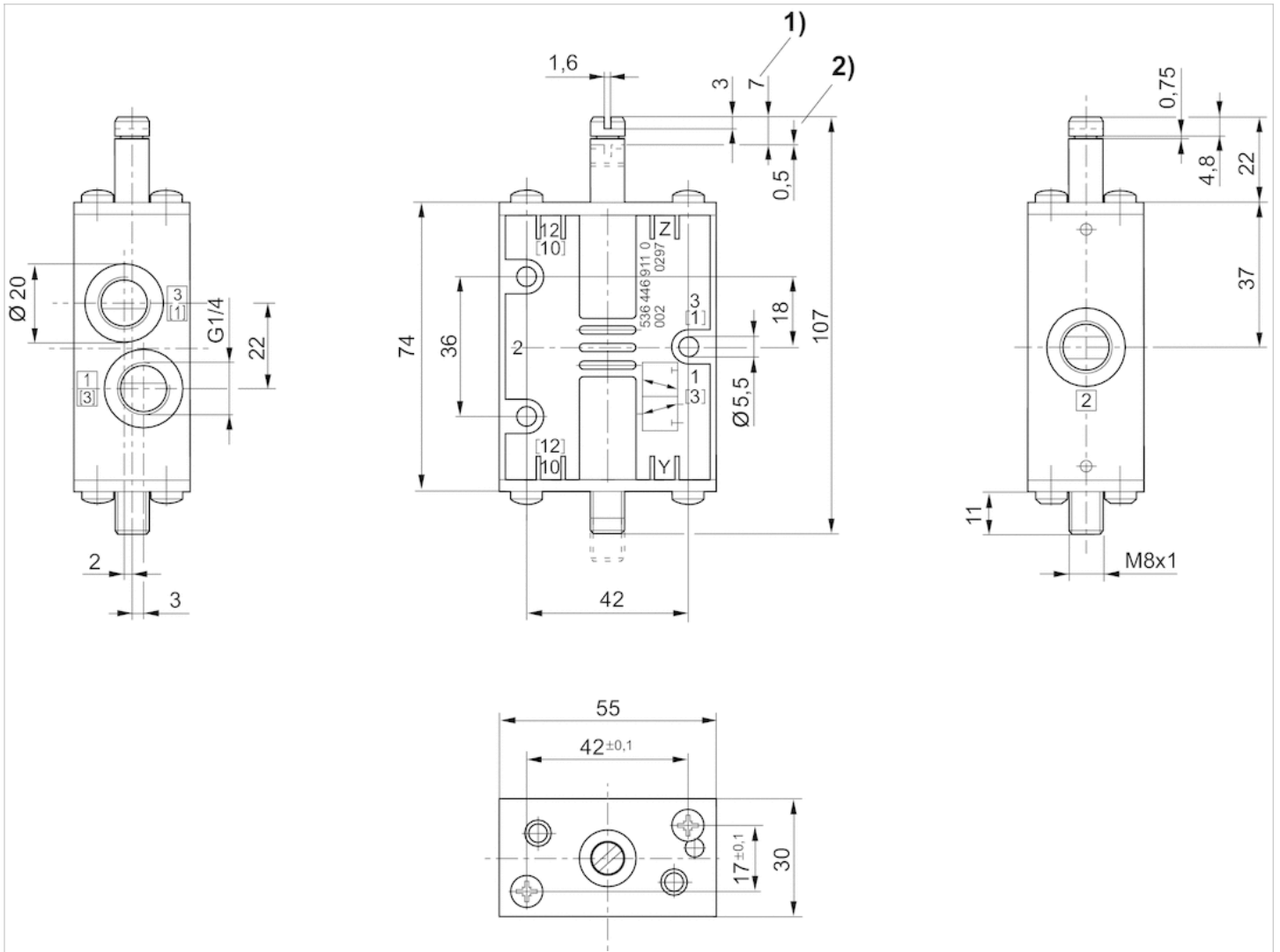

1) Stroke 2) Overstroke

Dimensions, Fig. 3

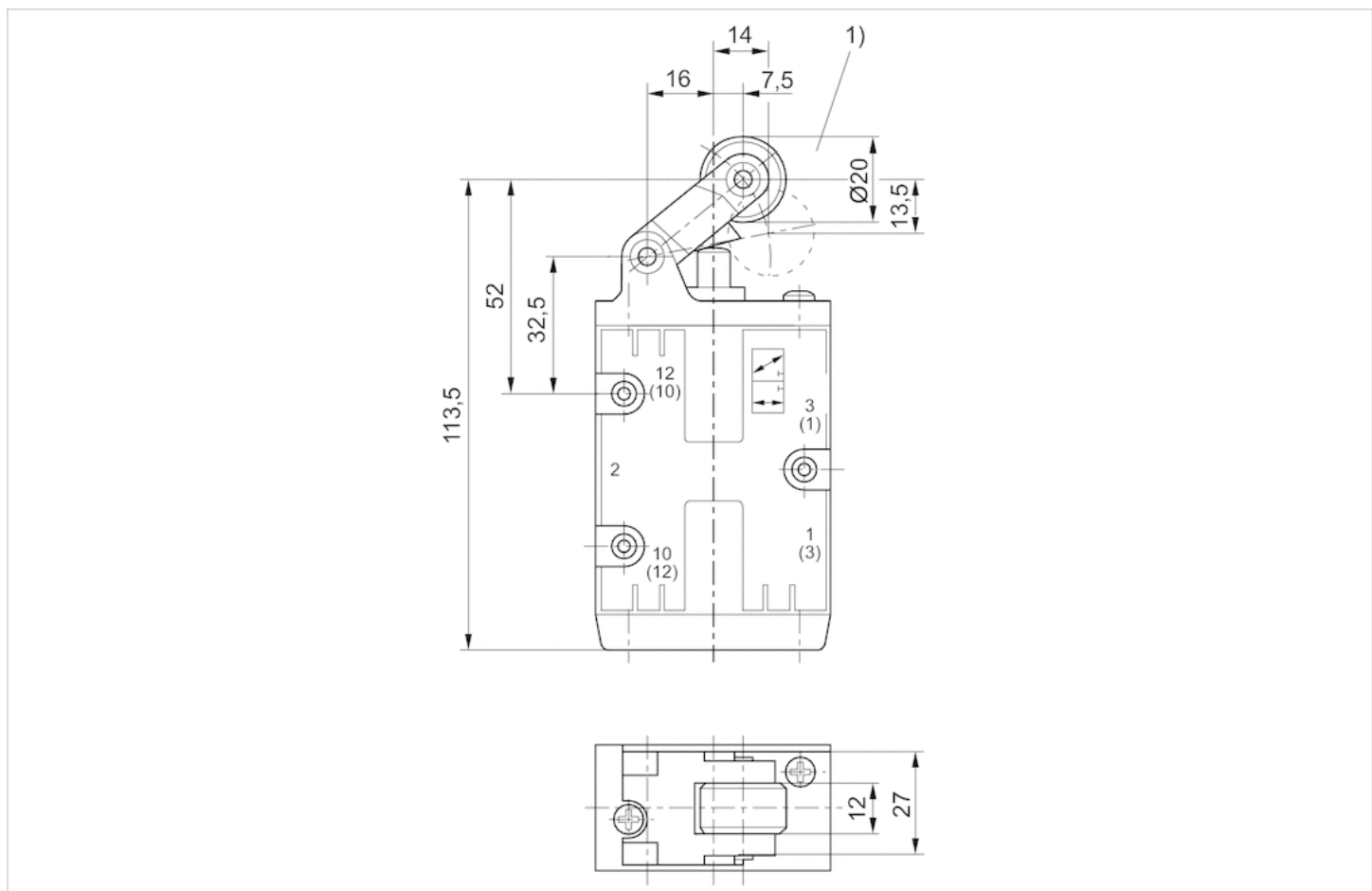

1) approach angle of rollers max. 30°

Dimensions, Fig. 4

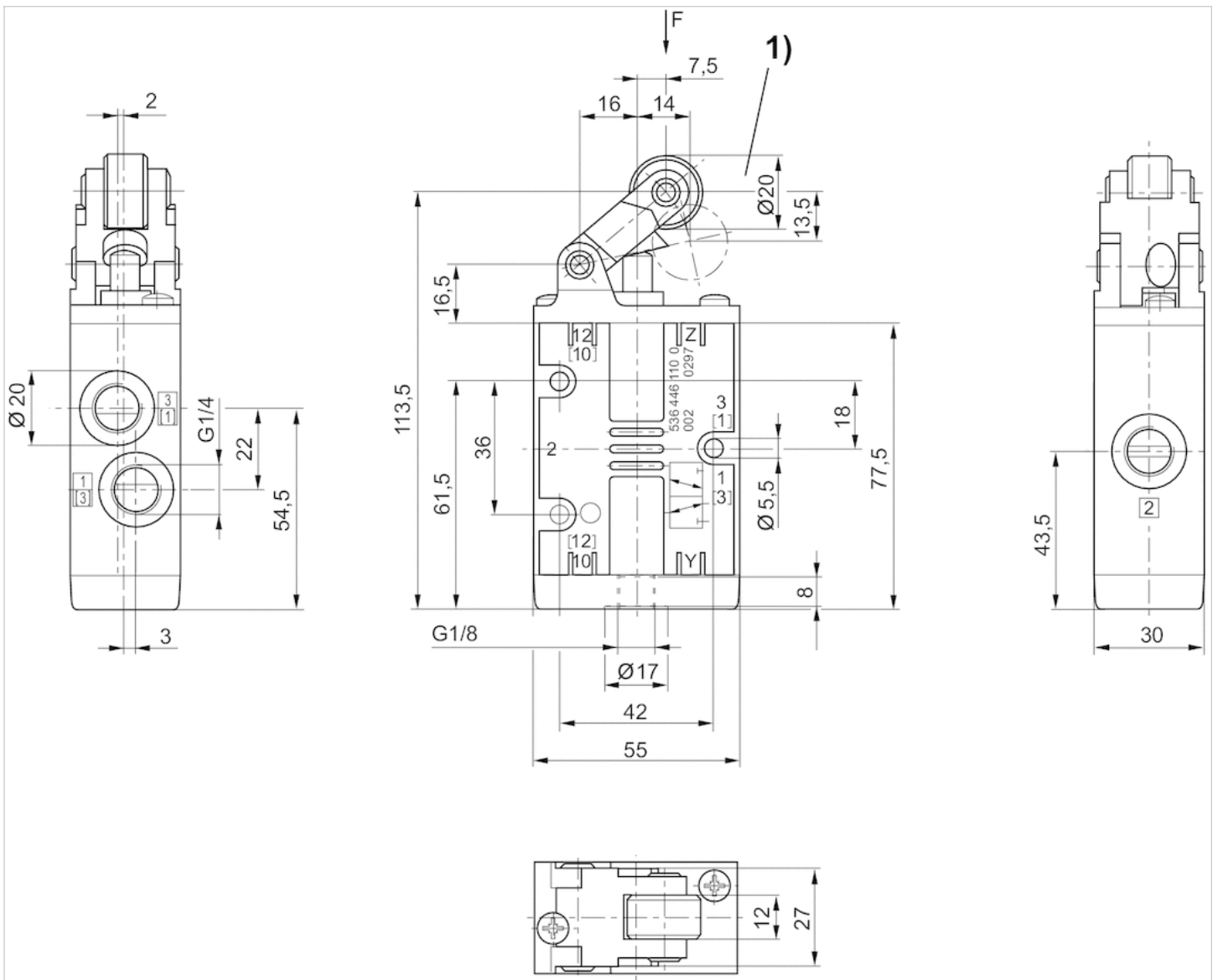

1) approach angle of rollers max. 30°

Dimensions, Fig. 5

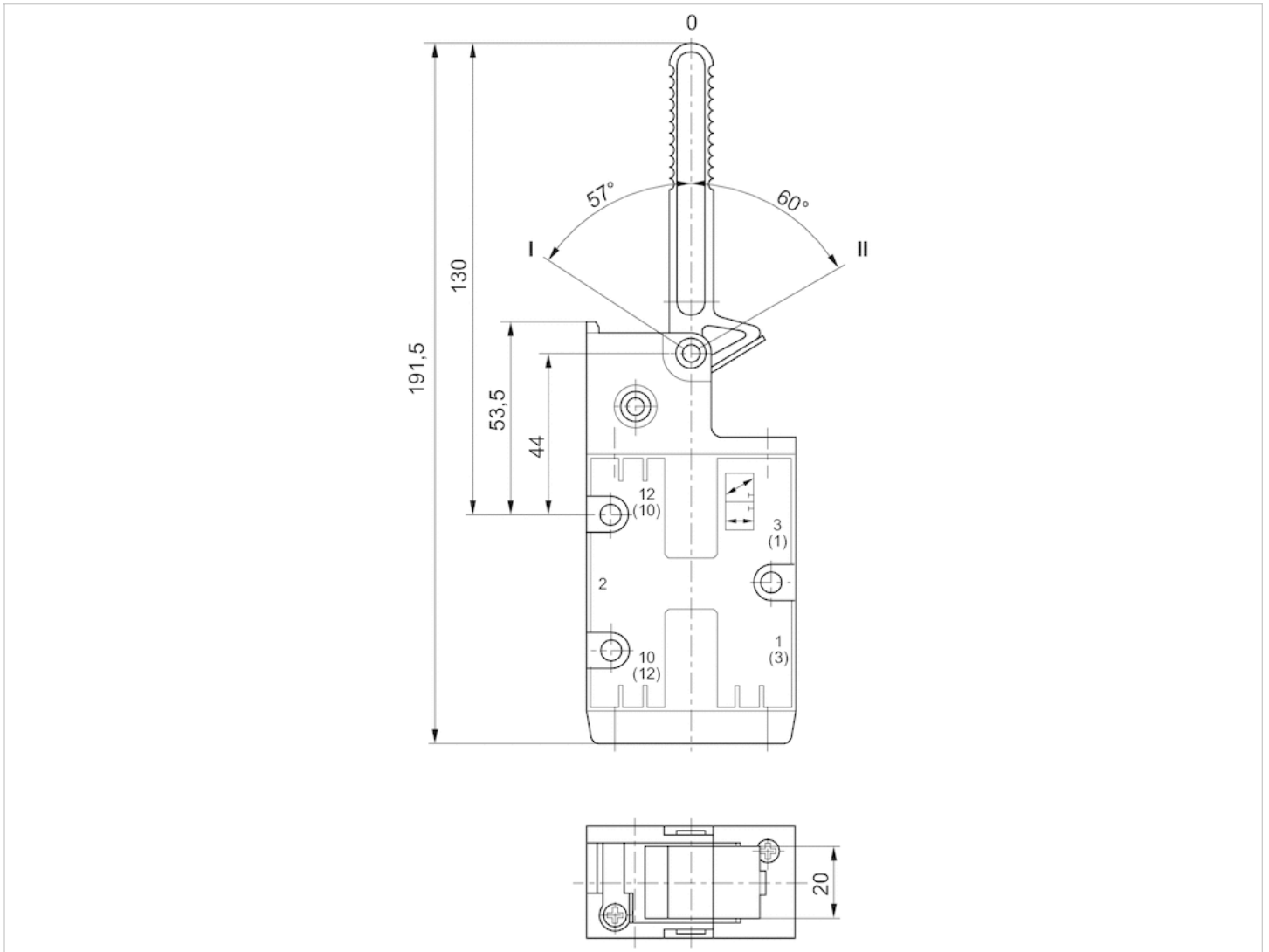

Position 0: initial position, position I: with detent, manual return, position II: automatic spring return.

Dimensions, Fig. 6

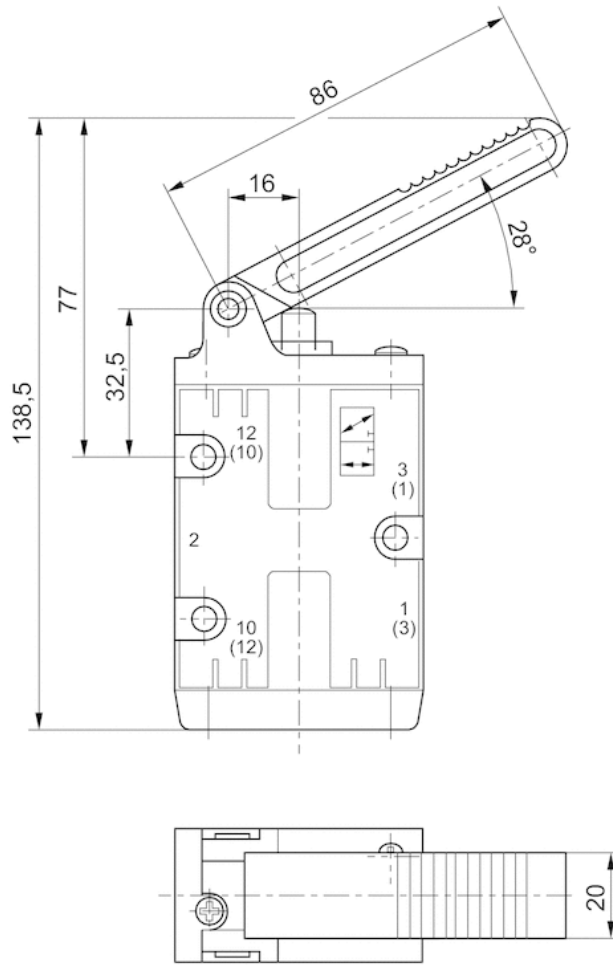

Dimensions of basic valve apply to all types of actuation.

Dimensions, Fig. 7

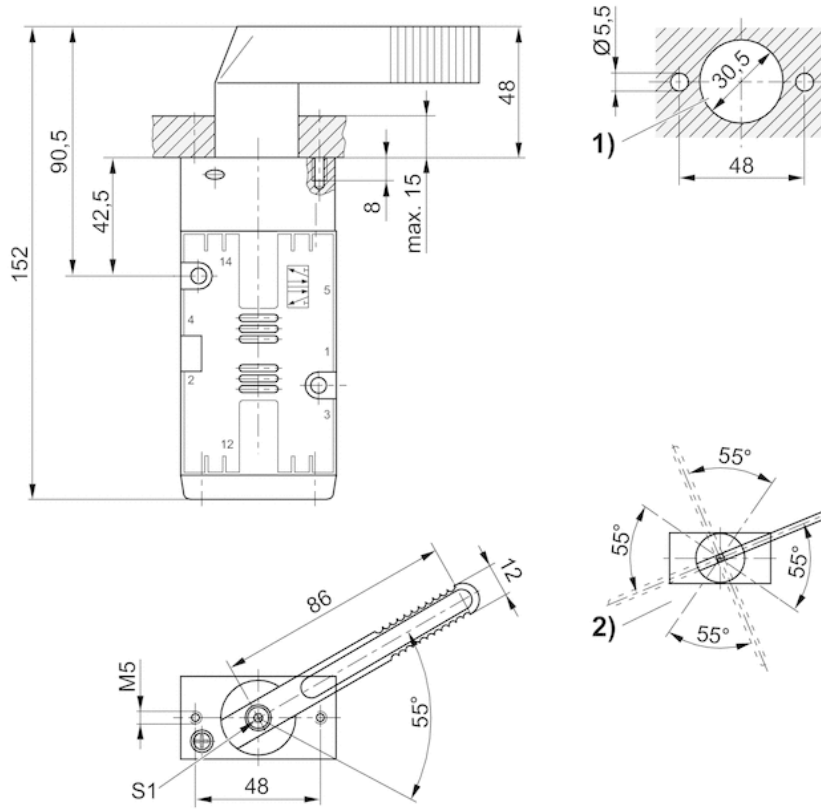

1) control panel installation (holes in mounting panel)

2) possible lever positions (basic position of hand lever adjustable in 90° steps after loosening screw "S1").

Dimensions, Fig. 8

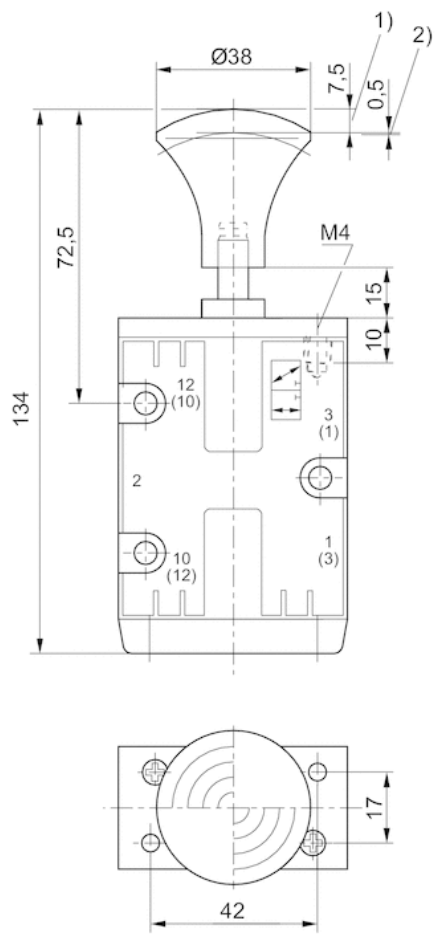

1) Stroke 2) Overstroke







3/2-directional valve, Series CD07

- Qn = 1400 l/min
- Compressed air connection output M14x1,5
- Pipe connection
- suitable for ATEX



Version	Spool valve, positive overlapping
Activation	Mechanical
Switching principle	3/2
Sealing principle	Soft sealing
Nominal flow Qn	1400 l/min
Working pressure min./max.	-0.95 ... 10 bar
Control pressure min./max.	See table below
Ambient temperature min./max.	-25 ... 80 °C
Medium temperature min./max.	-25 ... 80 °C
Medium	Compressed air
Oil content of compressed air	0 ... 1 mg/m ³
Weight	0.45 kg

Technical data

Part No.		Actuating element	Version	Compressed air connection Input	Compressed air connection Output
5634400000		Plunger	NC/NO	M14x1,5	M14x1,5
5634410000		Roller	NC/NO	M14x1,5	M14x1,5
5634460000		Button	NC/NO	M14x1,5	M14x1,5
5634461000		Button	-	M14x1,5	M14x1,5
5634469110		Button	NC/NO	M14x1,5	M14x1,5
5634469310		Button, beige	NC/NO	M14x1,5	M14x1,5

Part No.	Compressed air connection Exhaust	Compressed air connection Pilot control exhaust	Operating force
			min.
5634400000	M14x1,5	-	70 N
5634410000	M14x1,5	-	40 N
5634460000	M14x1,5	-	70 N
5634461000	M14x1,5	M10x1	40 N
5634469110	M14x1,5	M12x1,5	40 N
5634469310	M14x1,5	M10x1	40 N

Part No.	Control pressure min./max.	Housing material
5634400000	-	Die cast zinc Polyamide fiber-glass reinforced
5634410000	-	Die cast zinc Polyamide fiber-glass reinforced
5634460000	-	Die cast zinc Polyamide fiber-glass reinforced
5634461000	2 ... 10 bar	Die cast zinc
5634469110	5 ... 10 bar	Die cast zinc
5634469310	3 ... 10 bar	Die cast zinc

Part No.	Material actuating control	Fig.
5634400000	Stainless steel	Fig. 1
5634410000	Stainless steel	Fig. 2
5634460000	Polyoxymethylene	Fig. 3
5634461000	Polyoxymethylene	Fig. 3
5634469110	Polyoxymethylene	Fig. 4
5634469310	Polyoxymethylene	Fig. 5

Nominal flow Q_n at 6 bar and $\Delta p = 1$ bar

Technical information

option valve: The input and output compressed air connections can be exchanged.
The valve can thereby be used in the NC or NO operating mode.

Technical information

Material	
Housing	Die cast zinc Polyamide fiber-glass reinforced Die cast zinc
Seals	Acrylonitrile butadiene rubber
Actuating element	Stainless steel Polyoxymethylene

Dimensions

Dimensions, Fig. 1

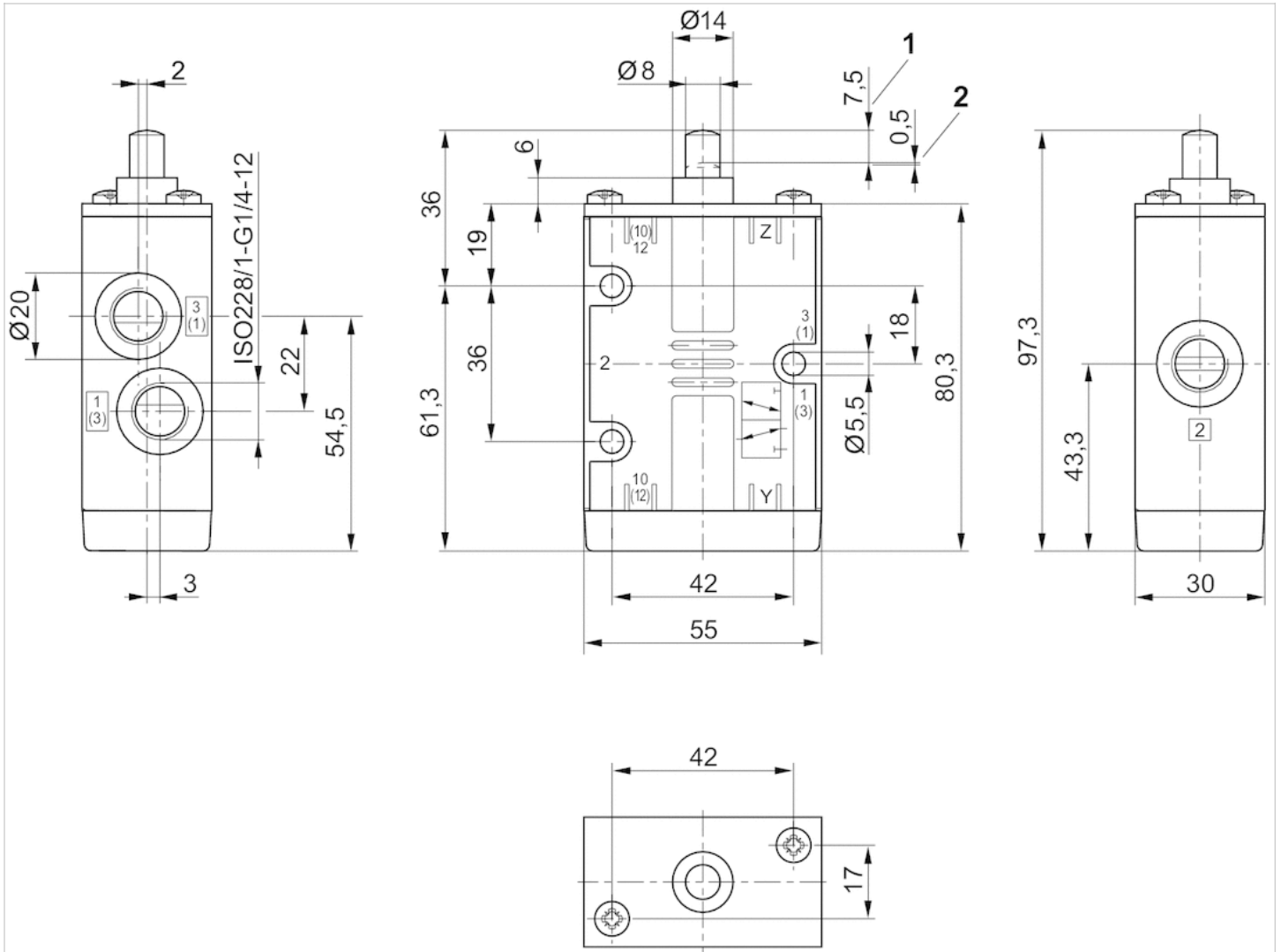

1) Stroke 2) Overstroke

Dimensions, Fig. 2

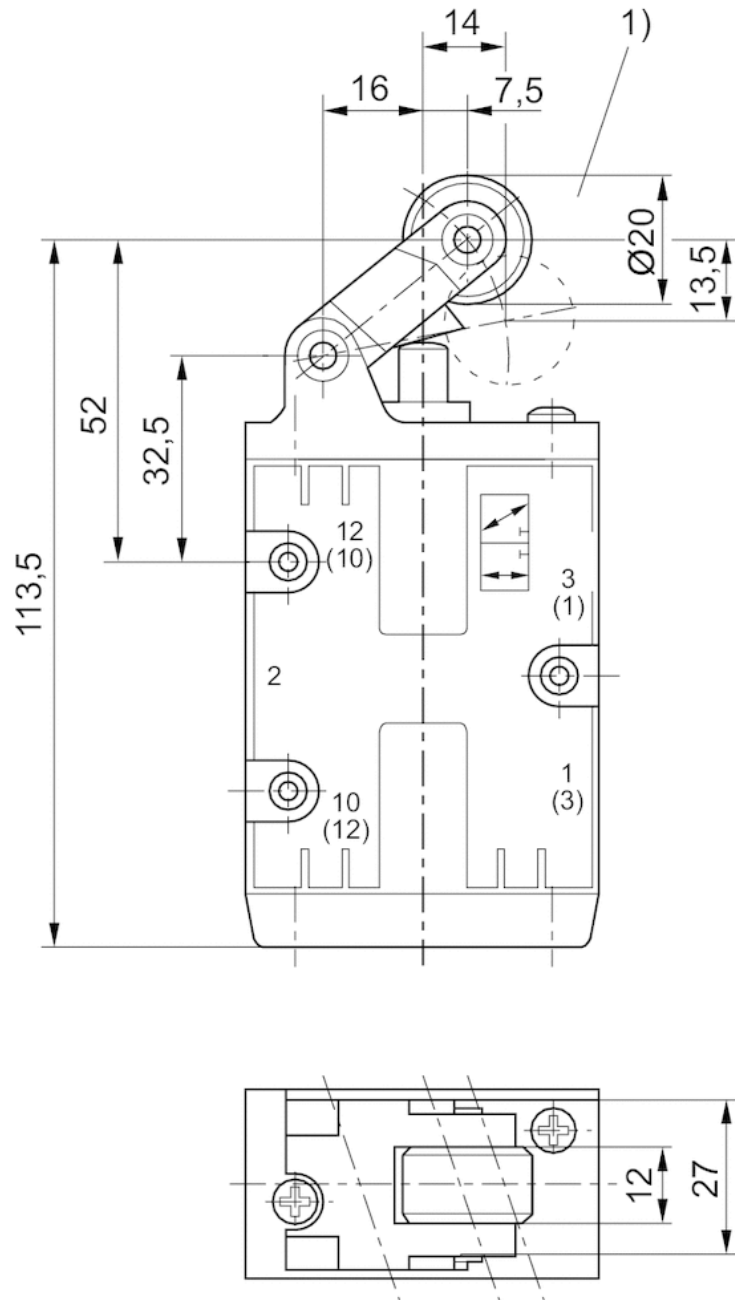

1) approach angle of rollers max. 30°

Dimensions, Fig. 3

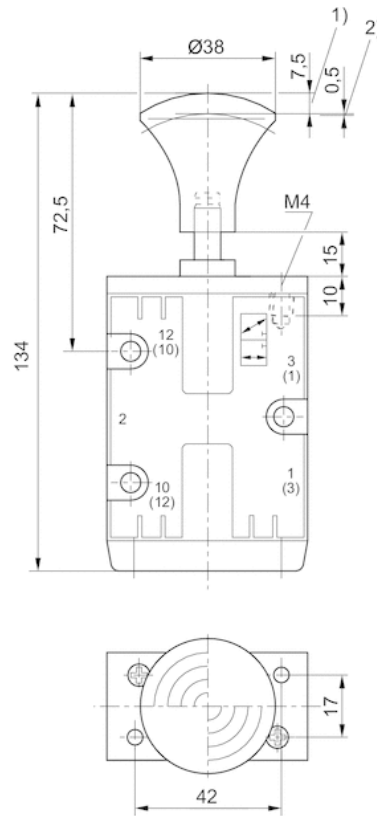

1) Stroke 2) Overstroke

Dimensions, Fig. 4

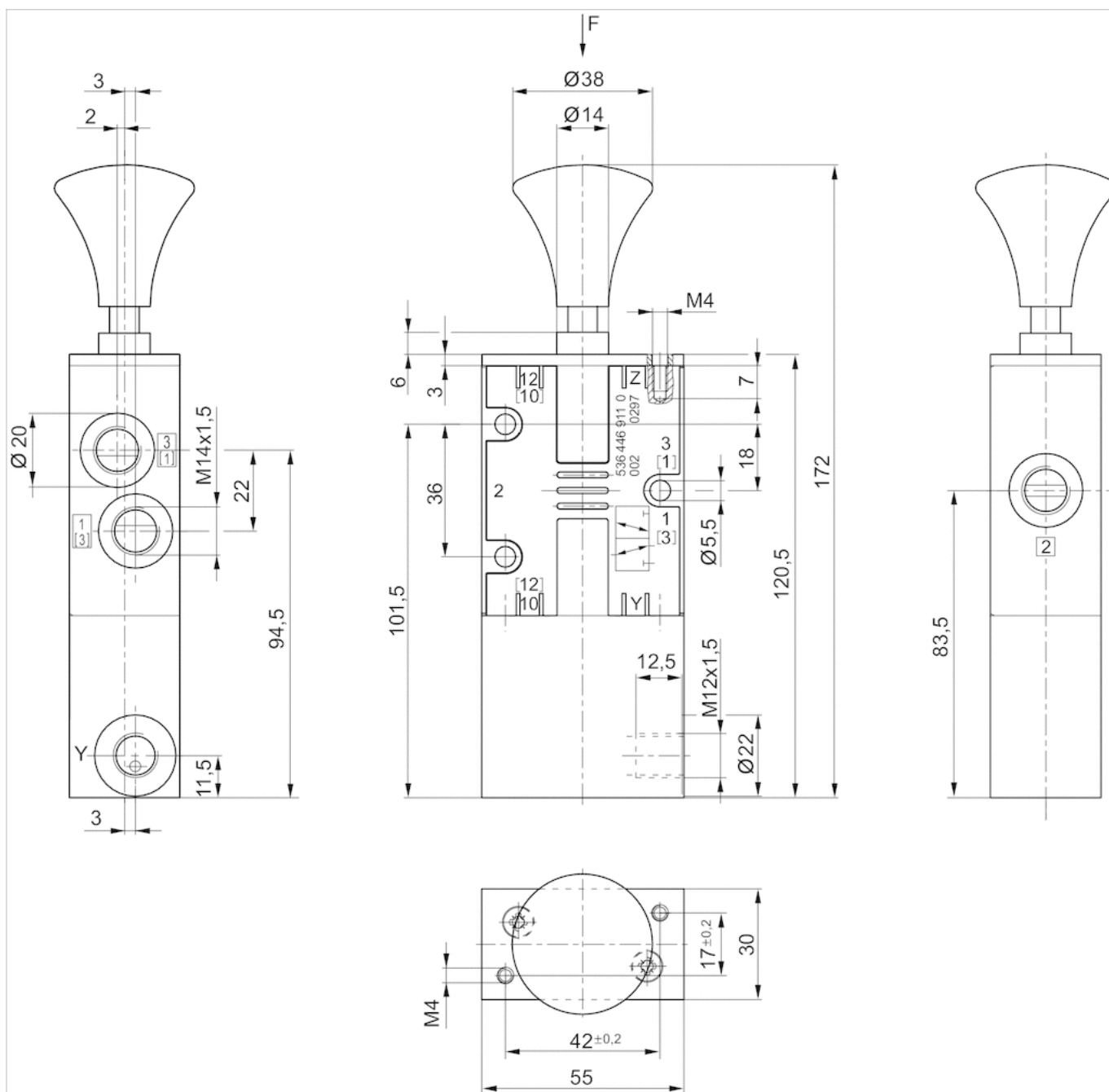

Dimensions, Fig. 5

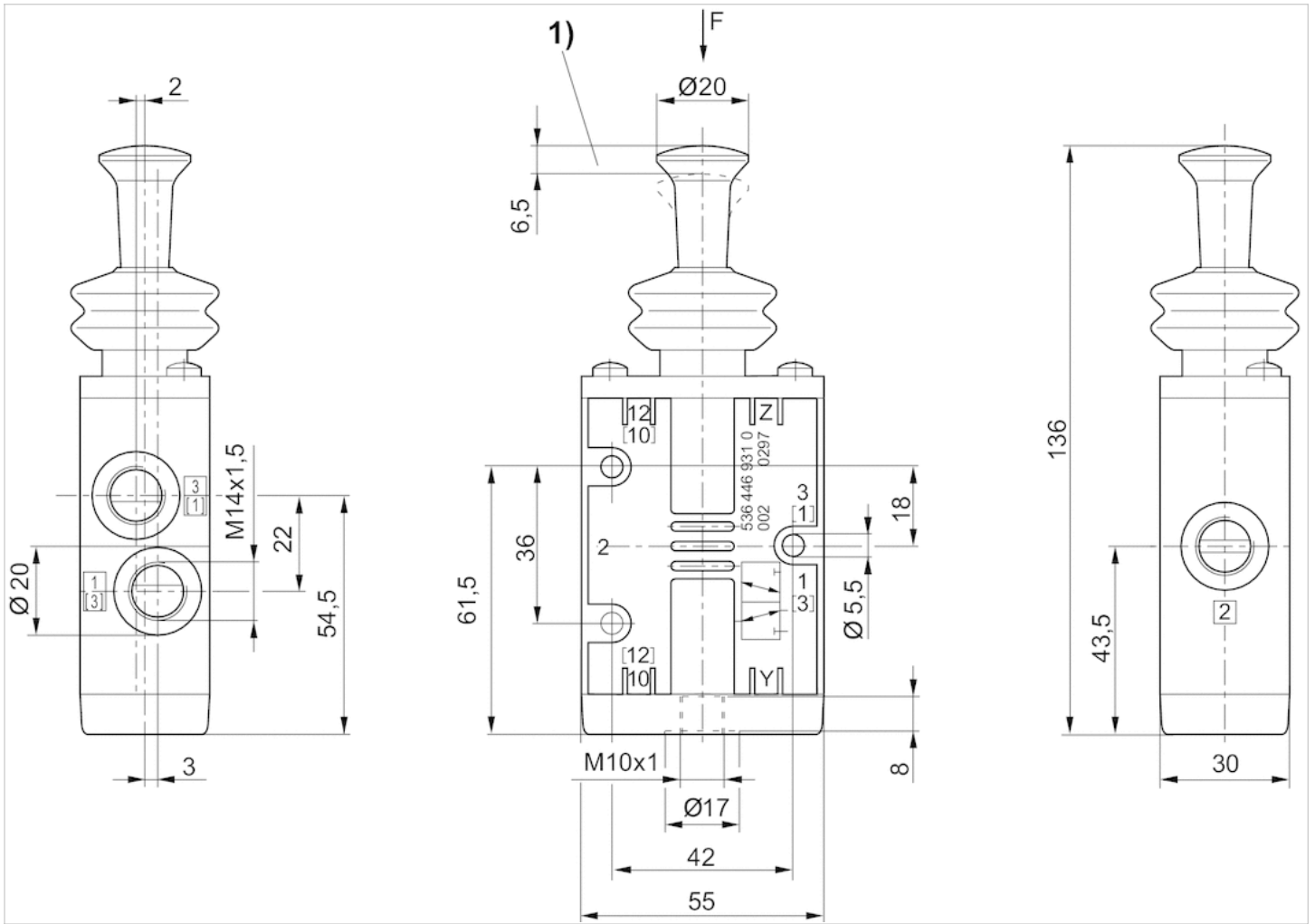

1) Stroke







5/2-directional valve, Series CD07

- Qn = 1200 l/min
- Compressed air connection output G 1/4
- Pipe connection
- suitable for ATEX



Version	Spool valve, positive overlapping
Activation	Mechanical
Switching principle	5/2
Sealing principle	Soft sealing
Nominal flow Qn	1200 l/min
Working pressure min./max.	-0.95 ... 10 bar
Control pressure min./max.	See table below
Ambient temperature min./max.	-25 ... 80 °C
Medium temperature min./max.	-25 ... 80 °C
Medium	Compressed air
Max. particle size	50 µm
Oil content of compressed air	0 ... 1 mg/m ³
Weight	See table below

Technical data

Part No.		Actuating element	Compressed air connection type
5634600100		Plunger	Internal thread
5634610100		Roller	Internal thread
5634630100		Hand lever, with detent, without detent	Internal thread
5634640100		Hand lever	Internal thread
5634650100		Rotary lever, with detent	Internal thread
5634660100		Button	Internal thread
5634669200		Button	-

Part No.	Compressed air connection Input	Compressed air connection Output	Compressed air connection Exhaust
5634600100	G 1/4	G 1/4	G 1/4
5634610100	G 1/4	G 1/4	G 1/4
5634630100	G 1/4	G 1/4	G 1/4
5634640100	G 1/4	G 1/4	G 1/4
5634650100	G 1/4	G 1/4	G 1/4
5634660100	G 1/4	G 1/4	G 1/4
5634669200	G 1/4	G 1/4	G 1/4

Part No.	Compressed air connection Pilot control exhaust	Operating force	Control pressure min./max.
		min.	
5634600100	-	70 N	-
5634610100	-	40 N	-
5634630100	-	20 N	-
5634640100	-	15 N	-
5634650100	-	15 N	-
5634660100	-	70 N	-

Part No.	Compressed air connection Pilot control exhaust	Operating force	Control pressure min./max.
		min.	
5634669200	G 1/8	80 N	5 ... 10 bar

Part No.	Housing material	Material actuating control	Weight
5634600100	Die cast zinc Polyamide fiber-glass reinforced	Stainless steel	0.54 kg
5634610100	Die cast zinc Polyamide fiber-glass reinforced	Stainless steel	0.59 kg
5634630100	Die cast zinc Polyamide fiber-glass reinforced	Polyoxymethylene	0.62 kg
5634640100	Die cast zinc Polyamide fiber-glass reinforced	Polyoxymethylene	0.59 kg
5634650100	Die cast zinc Polyamide fiber-glass reinforced	Polyoxymethylene	0.64 kg
5634660100	Die cast zinc Polyamide fiber-glass reinforced	Polyoxymethylene	0.54 kg
5634669200	Die cast zinc	Polyoxymethylene	0.54 kg

Part No.	Fig.
5634600100	Fig. 1
5634610100	Fig. 2
5634630100	Fig. 3
5634640100	Fig. 4
5634650100	Fig. 5
5634660100	Fig. 6
5634669200	Fig. 7

Nominal flow Q_n at 6 bar and $\Delta p = 1$ bar

Technical information

Material	
Housing	Die cast zinc Polyamide fiber-glass reinforced Die cast zinc
Seals	Acrylonitrile butadiene rubber
Actuating element	Stainless steel Polyoxymethylene

Dimensions

Dimensions, Fig. 1

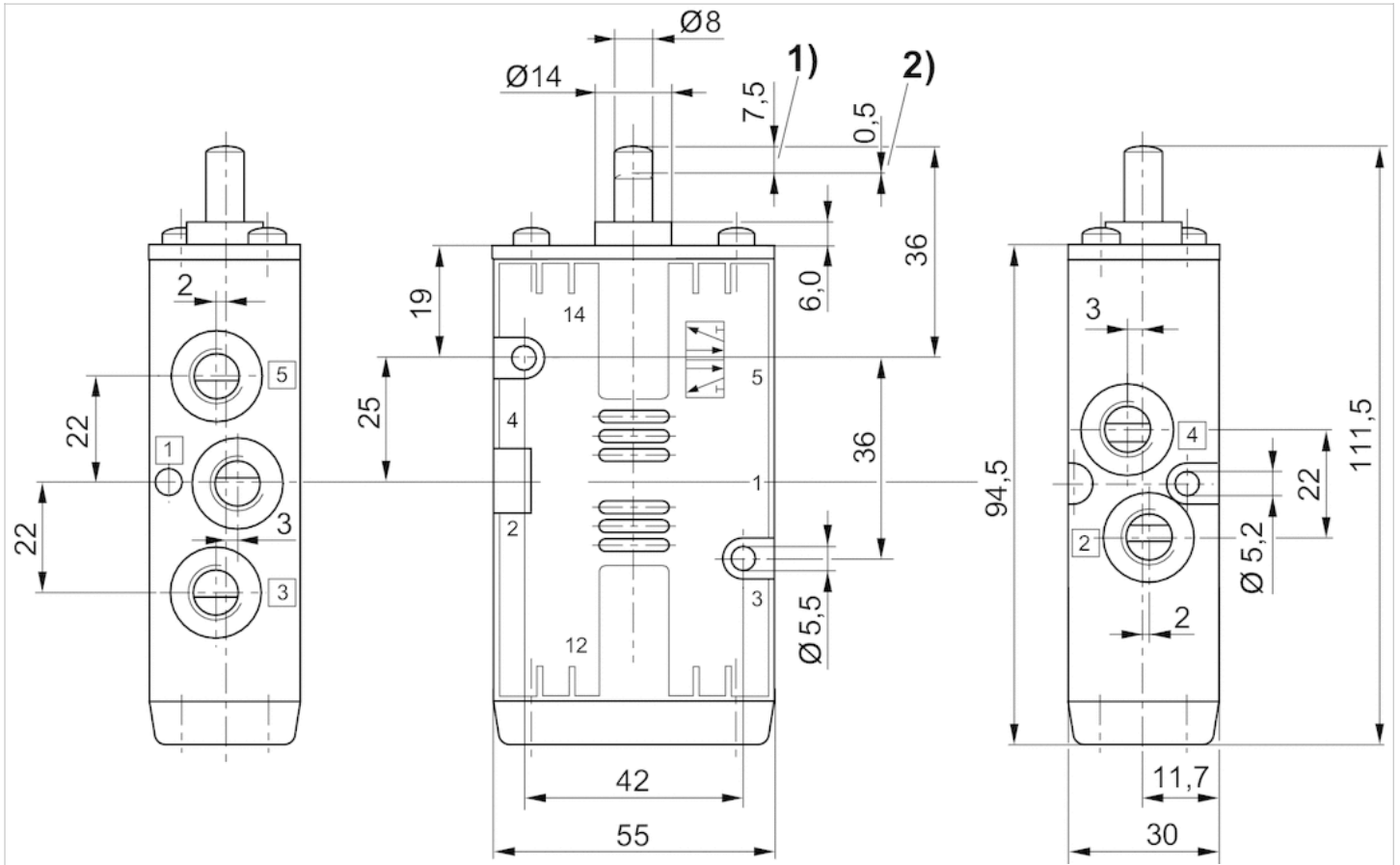

1) Stroke 2) Overstroke

Dimensions of basic valve apply to all types of actuation.

Dimensions, Fig. 2

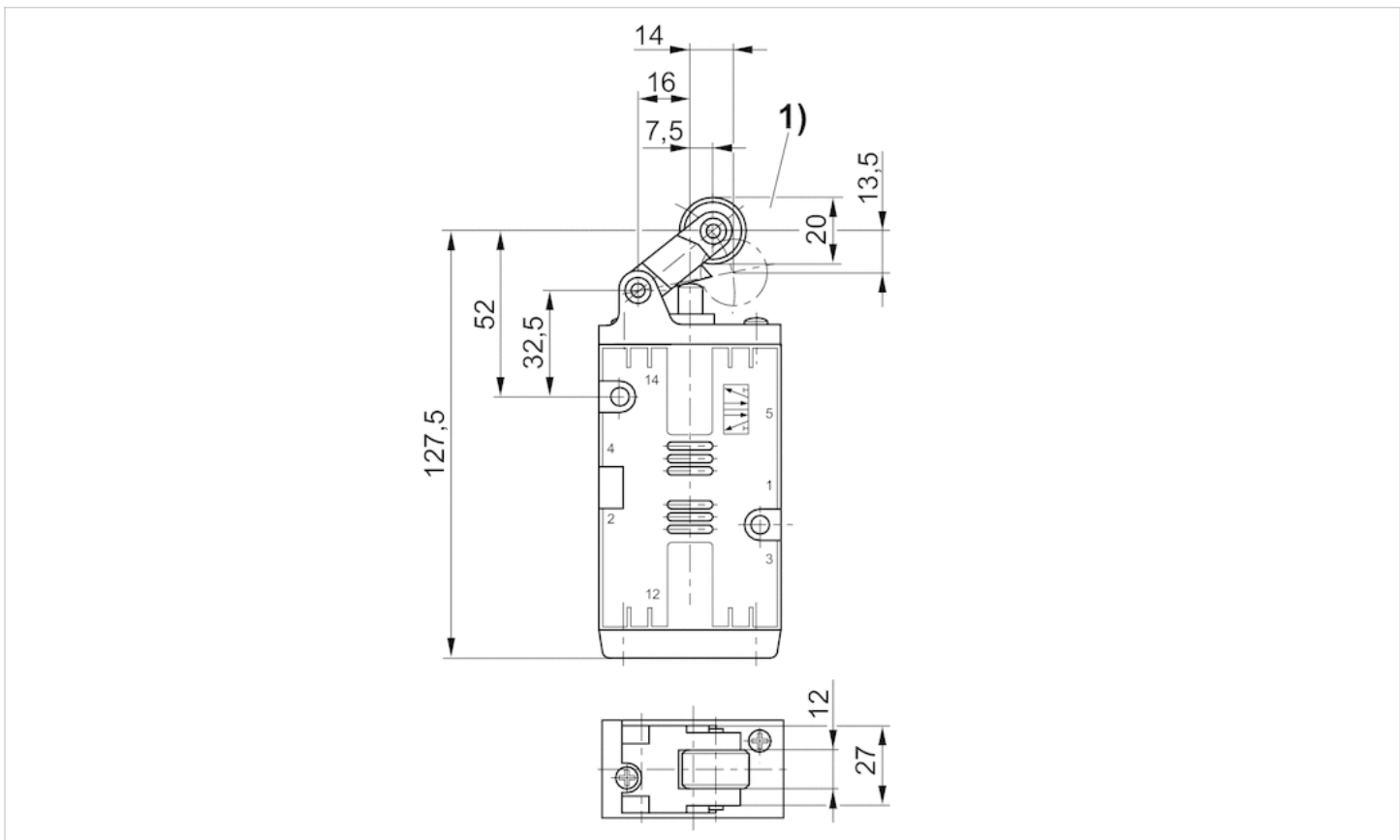

1) approach angle of rollers max. 30°

Dimensions, Fig. 3

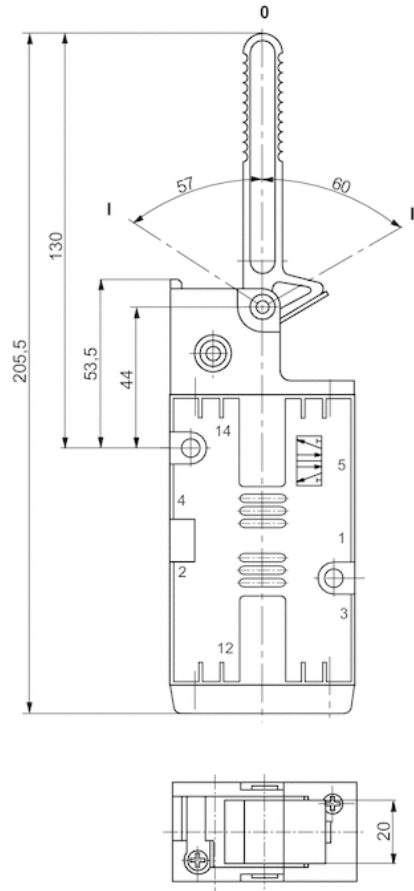

Position 0: initial position, position I: with detent, manual return, position II: automatic spring return.

Dimensions, Fig. 4

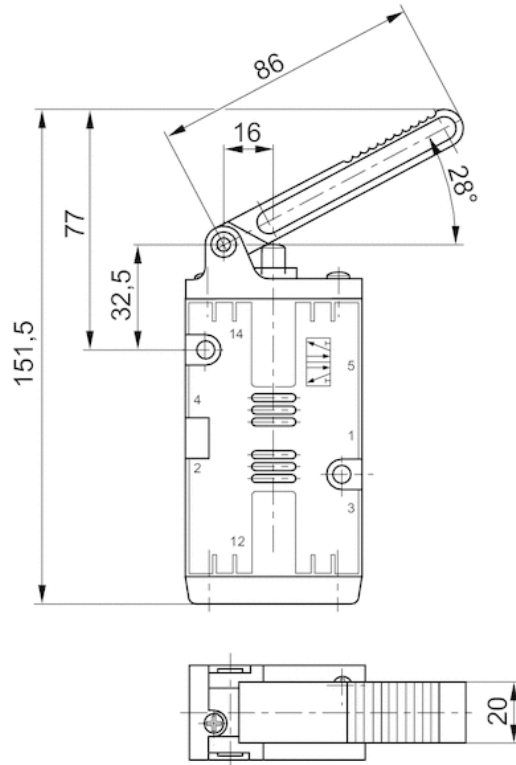

Dimensions, Fig. 5

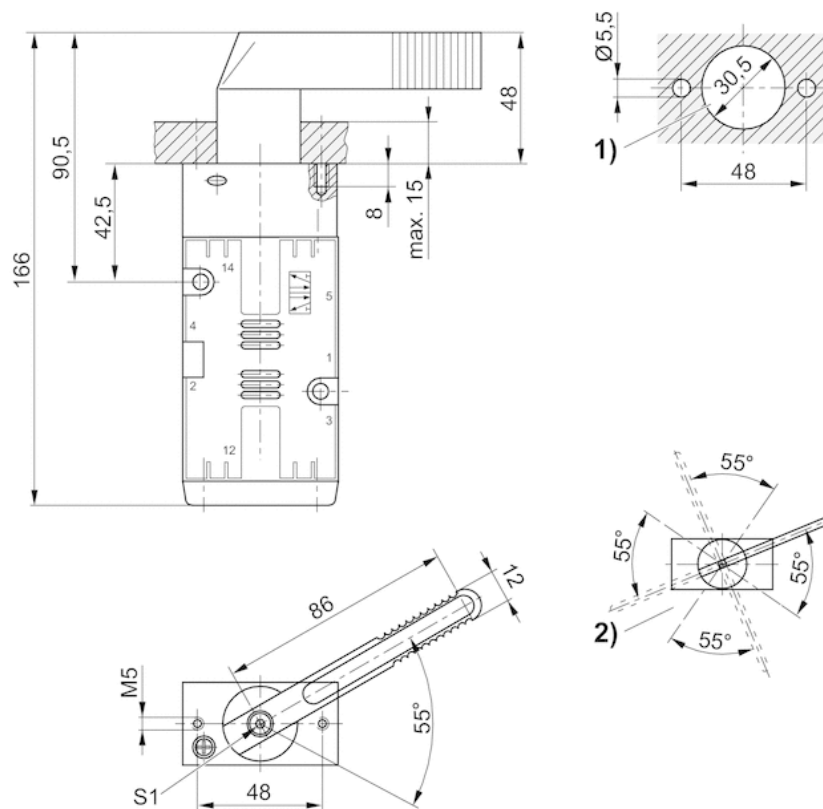

1) control panel installation (holes in mounting panel)

2) possible lever positions (basic position of hand lever adjustable in 90° steps after loosening screw "S1").

Dimensions, Fig. 6

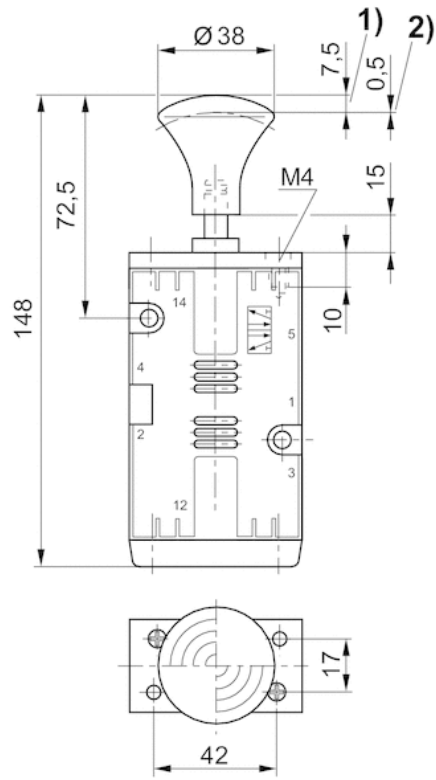

1) Stroke 2) Overstroke

Dimensions, Fig. 7

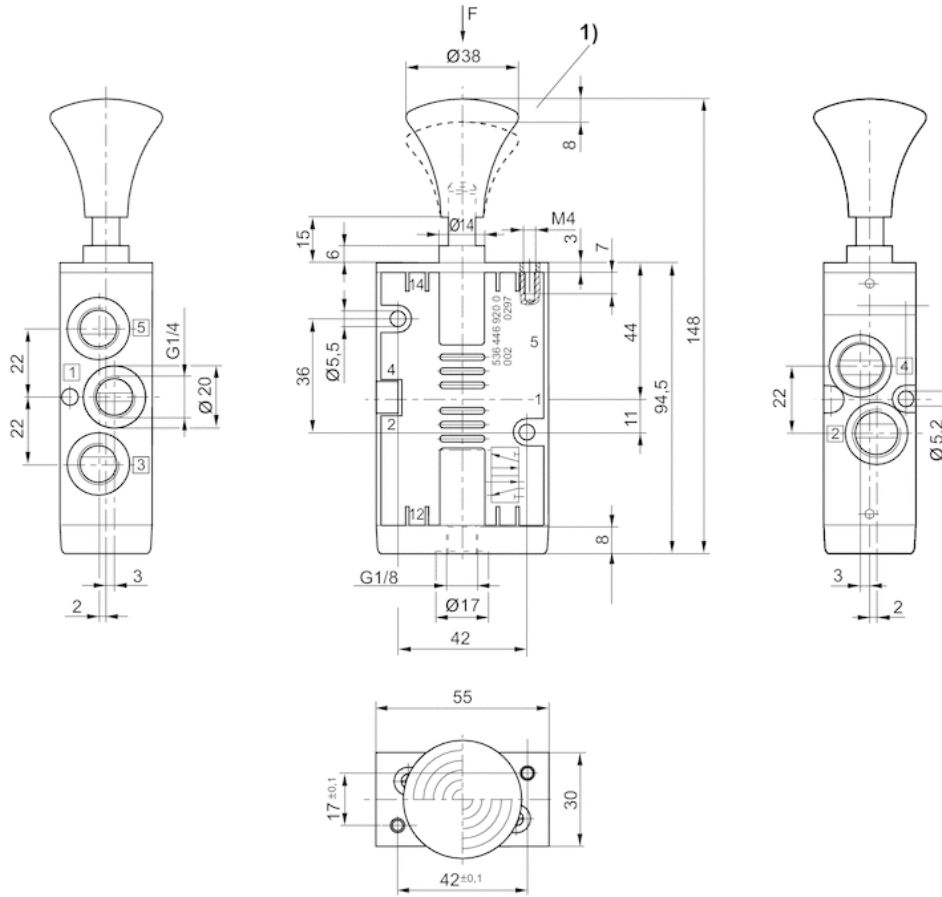

1) Stroke



5/2-directional valve, Series CD07

- Qn = 1200 l/min
- Compressed air connection output G 1/4
- single solenoid
- Pipe connection
- -30 °C cold-resistant
- suitable for ATEX



Version	Spool valve, positive overlapping
Activation	Mechanical
Switching principle	5/2
Sealing principle	Soft sealing
Nominal flow Qn	1200 l/min
Working pressure min./max.	-0.95 ... 10 bar
Ambient temperature min./max.	-40 ... 70 °C
Medium temperature min./max.	-40 ... 70 °C
Medium	Compressed air
Max. particle size	50 µm
Oil content of compressed air	0 ... 1 mg/m ³
Weight	See table below

Technical data

Part No.		Actuating element	Compressed air connection type
5634610190		Roller	Internal thread
5634630190		Hand lever, with detent, without detent	Internal thread

Part No.	Compressed air connection Input	Compressed air connection Output	Compressed air connection Exhaust
5634610190	G 1/4	G 1/4	G 1/4
5634630190	G 1/4	G 1/4	G 1/4

Part No.	Operating force	Material actuating control	Weight	Fig.
	min.			
5634610190	52 N	Polyoxymethylene	0.59 kg	Fig. 1
5634630190	26 N	Polyoxymethylene Aluminum	0.62 kg	Fig. 2

Nominal flow Qn at 6 bar and $\Delta p = 1$ bar

Technical information

Material	
Housing	Die cast zinc Polyamide fiber-glass reinforced
Seals	Acrylonitrile butadiene rubber Polyurethane
Actuating element	Polyoxymethylene Polyoxymethylene, Aluminum

Dimensions

Dimensions, Fig. 1

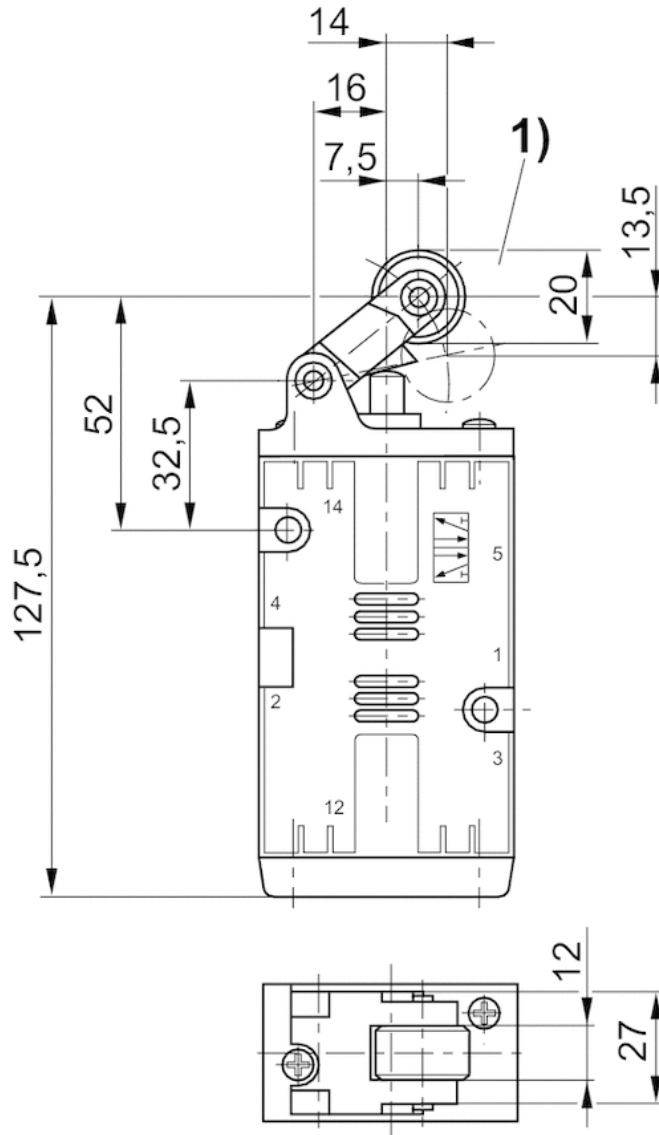

1) approach angle of rollers max. 30°

Dimensions, Fig. 2

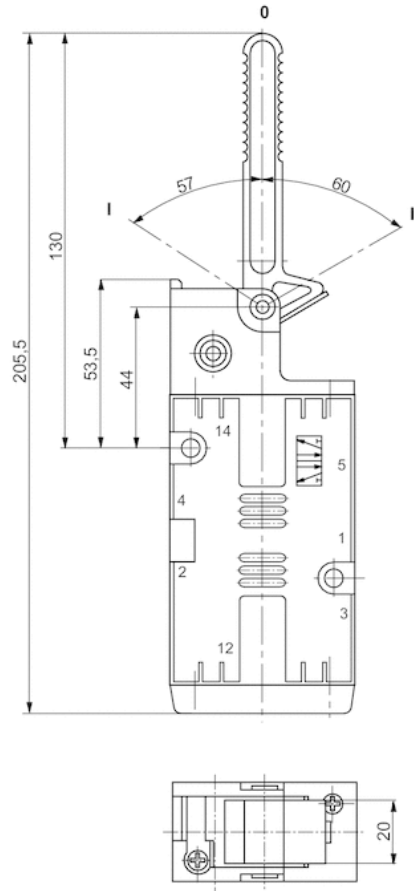

Position 0: initial position, position I: with detent, manual return, position II: automatic spring return.

5/2-directional valve, Series CD07

- Qn = 1200 l/min
- Compressed air connection output G 1/4
- Pipe connection
- suitable for ATEX



Version	Spool valve, positive overlapping
Activation	Mechanical
Actuating element	Pedal
Switching principle	5/2
Sealing principle	Soft sealing
Nominal flow Qn	1200 l/min
Working pressure min./max.	-0.95 ... 10 bar
Ambient temperature min./max.	-25 ... 80 °C
Medium temperature min./max.	-25 ... 80 °C
Medium	Compressed air
Max. particle size	50 µm
Oil content of compressed air	0 ... 1 mg/m³
Weight	0.76 kg

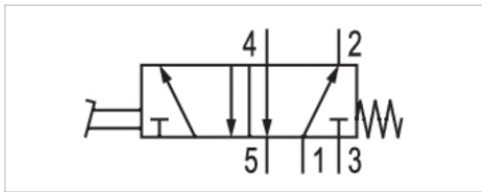

Technical data

Part No.	Compressed air connection type	Compressed air connection Input	Compressed air connection Output
5634670100	Internal thread	G 1/4	G 1/4

Part No.	Compressed air connection Exhaust
5634670100	G 1/4

Nominal flow Qn at 6 bar and Δp = 1 bar

Technical information

Material	
Housing	Die cast zinc Polyamide fiber-glass reinforced
Seals	Acrylonitrile butadiene rubber

Dimensions

Dimensions

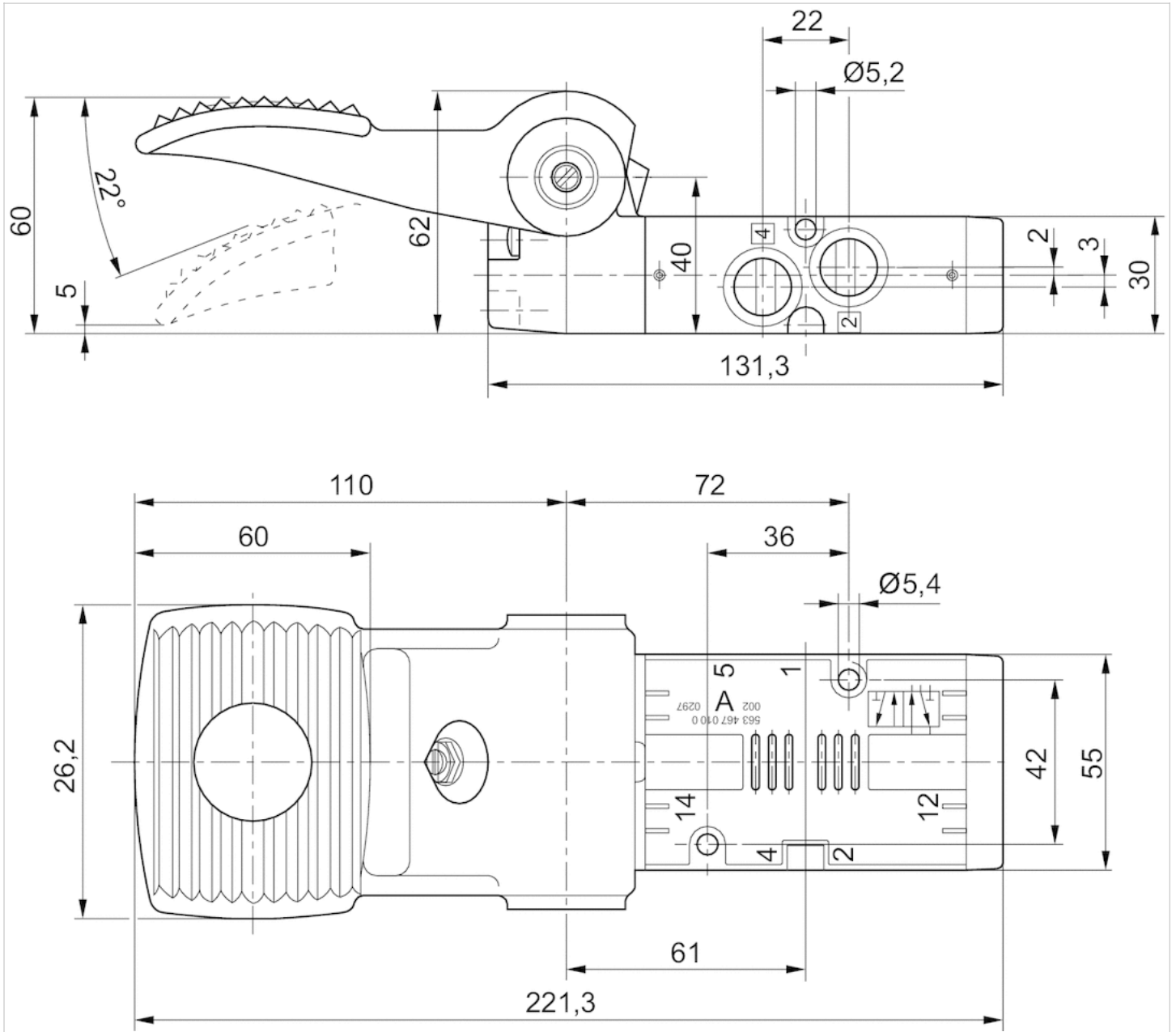

5/2-directional valve, Series CD07

- Qn = 1200 l/min
- Compressed air connection output G 1/4
- Pipe connection
- suitable for ATEX



Version	Spool valve, positive overlapping
Activation	Mechanical
Lock type	not lockable
Actuating element	Pedal, with detent
Switching principle	5/2
Sealing principle	Soft sealing
Nominal flow Qn	1200 l/min
Working pressure min./max.	-0.95 ... 10 bar
Ambient temperature min./max.	-25 ... 80 °C
Medium temperature min./max.	-25 ... 80 °C
Medium	Compressed air
Max. particle size	50 µm
Oil content of compressed air	0 ... 1 mg/m³
Weight	1.56 kg

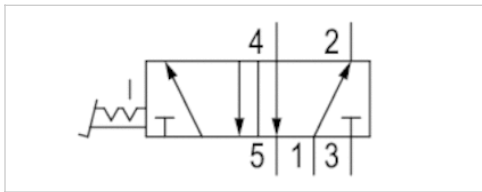

Technical data

Part No.	Compressed air connection type	Compressed air connection Input	Compressed air connection Output
5634695100	Internal thread	G 1/4	G 1/4

Part No.	Compressed air connection Exhaust
5634695100	G 1/4

Nominal flow Qn at 6 bar and Δp = 1 bar

Dimensions

Dimensions

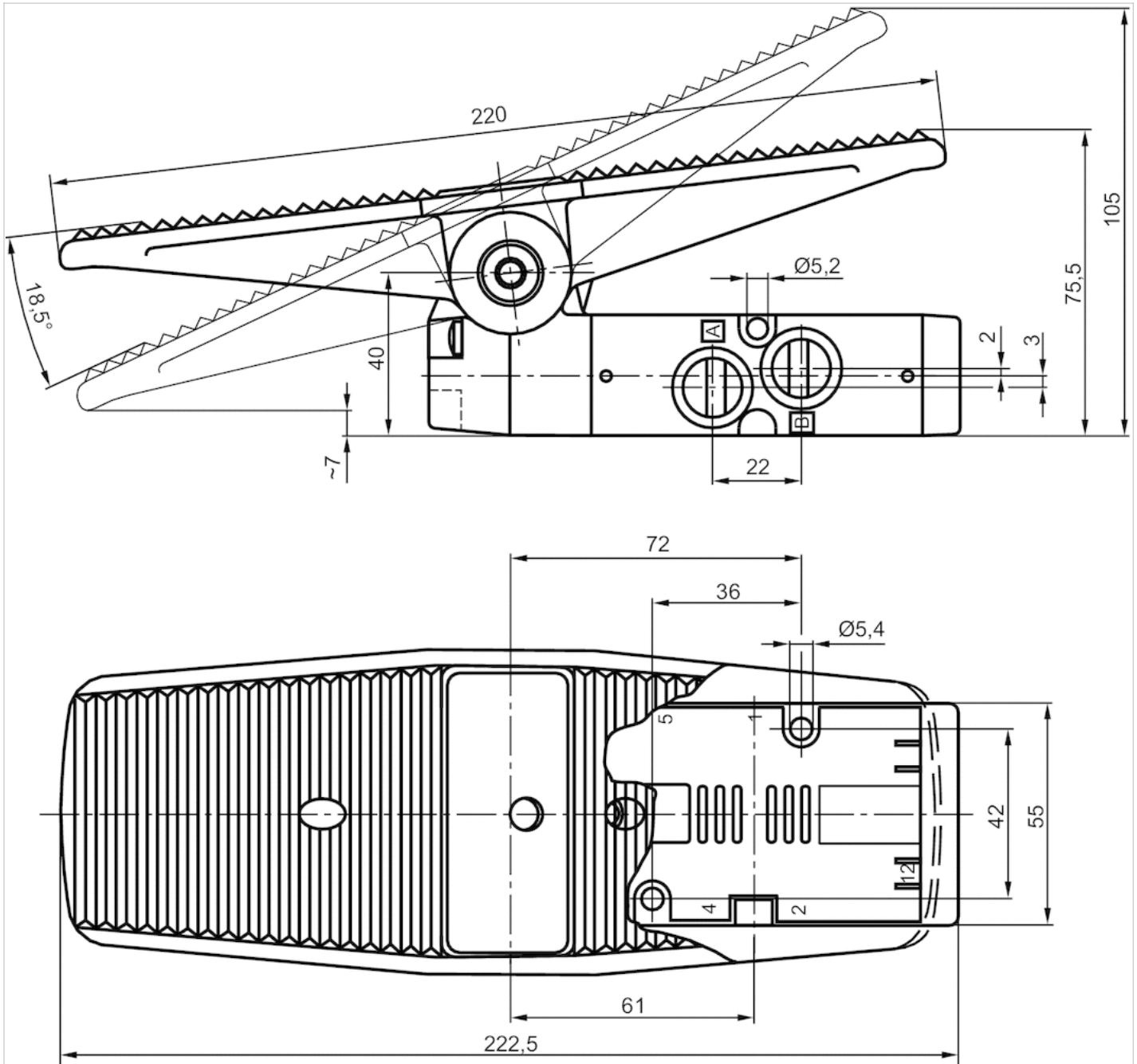



Valve plug connector, series CON-VP

- Socket, 2+E, angled, 90°
- EN 175301-803
- unshielded
- with LED Yellow Red



Connection type	Screws
Ambient temperature min./max.	-40 ... 90 °C
Operational voltage	See table below
Protection class	IP65
Mounting screw tightening torque	0.4 Nm
Weight	See table below

Technical data

Part No.		Operational voltage	Protective circuit	Contact assignment	LED status display
1834484101		24 V AC/DC	Z-diode	2+E	Yellow
1834484102		110 V AC	Varistor	2+E	Red
1834484103		230 V AC	Varistor	2+E	Red

Part No.	suitable cable-Ø min./max	Seal	Weight	
1834484101	6 / 8 mm	Silicone caoutchouc	0.03 kg	1)
1834484102	6 / 8 mm	caoutchouc/butadiene caoutchouc	0.03 kg	2)
1834484103	6 / 8 mm	Silicone caoutchouc	0.025 kg	2)

1) Flat gasket

2) Profile seal

Technical information

The specified protection class is only valid in assembled and tested state.

Technical information

Material	
Seals	Silicone caoutchouc caoutchouc/butadiene caoutchouc

Dimensions

Dimensions

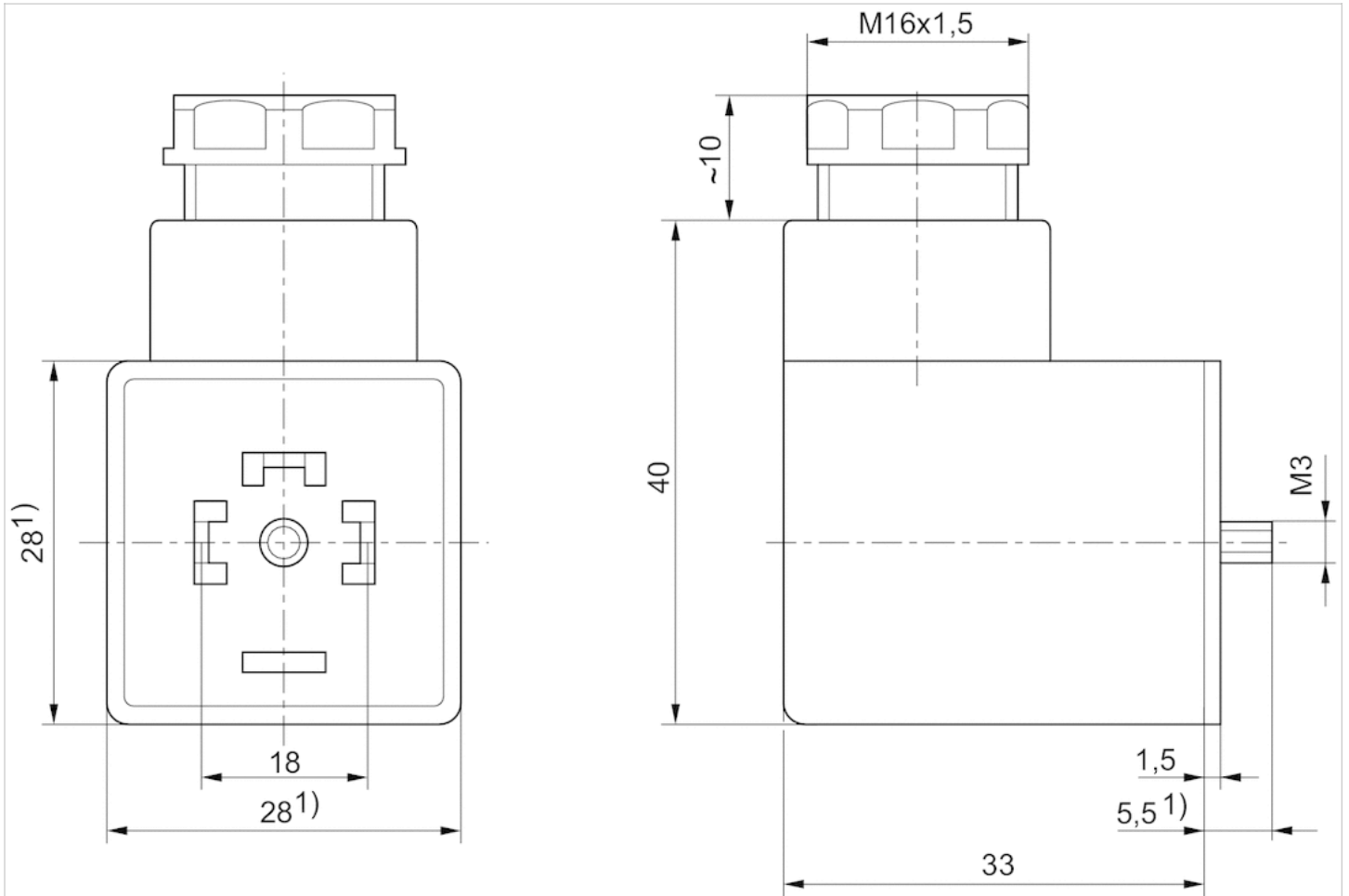

1) Max.

Valve plug connector, series CON-VP

- Socket, 2+E, angled, 90° Socket, 3+E, angled, 90°
- EN 175301-803
- unshielded



Connection type	Screws
Ambient temperature min./max.	-40 ... 90 °C
Protection class	IP65
Mounting screw tightening torque	0.4 Nm
Weight	0.03 kg

Technical data

Part No.		Electrical connection	Max. current	Contact assignment	suitable cable-Ø min./max
		1			
1834484048		Socket 2+E angled 90°	10 A	2+E	6 / 8 mm
1834484059		Socket 3+E angled 90°	10 A	3+E	6 / 8 mm

Profile seal

Technical information

The specified protection class is only valid in assembled and tested state.

Technical information

Material	
Seals	caoutchouc/butadiene caoutchouc

Dimensions

Dimensions

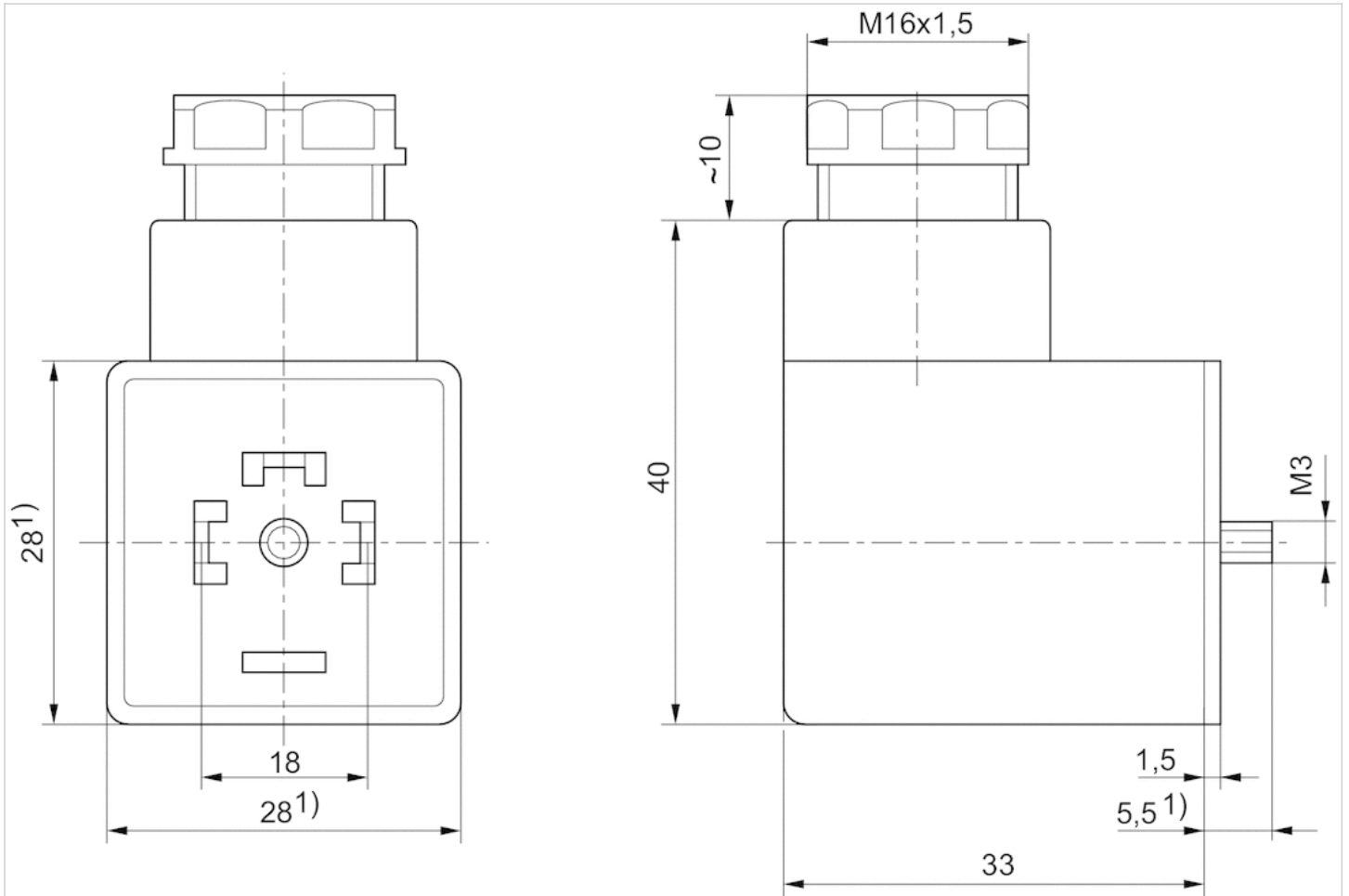

1) Max.





Valve plug connector, series CON-VP

- Socket form A 2+E angled 90°
- open cable ends 3-pin
- with cable
- unshielded



Ambient temperature min./max.	-20 ... 80 °C
Operational voltage	See table below
Protection class	IP67
Wire cross-section	0.75 mm ²
Mounting screw tightening torque	0.4 Nm
Weight	See table below

Technical data

Part No.		Operational voltage	Protective circuit	Contact assignment	LED status display
1834484160		230 V AC/DC	-	2+E	-
1834484162		24 V AC/DC	Z-diode	2+E	Yellow
1834484163		24 V AC/DC	Z-diode	2+E	Yellow
1834484164		230 V AC/DC	Varistor	2+E	Red
1834484165		230 V AC/DC	Varistor	2+E	Red

Part No.	Number of wires	Cable-Ø	Cable length	Weight	Fig.	
1834484160	3	5.9 mm	3 m	0.2 kg	Fig. 1	1)
1834484162	3	5.9 mm	3 m	0.2 kg	Fig. 2	-
1834484163	3	5.9 mm	5 m	0.31 kg	Fig. 2	-
1834484164	3	5.9 mm	3 m	0.2 kg	Fig. 2	-
1834484165	3	5.9 mm	5 m	0.31 kg	Fig. 2	-

1) Scope of delivery incl. flat gasket

Technical information

The specified protection class is only valid in assembled and tested state.

Technical information

Material	
Seals	caoutchouc/butadiene caoutchouc
Cable sheath	Polyvinyl chloride

Dimensions

Fig. 1

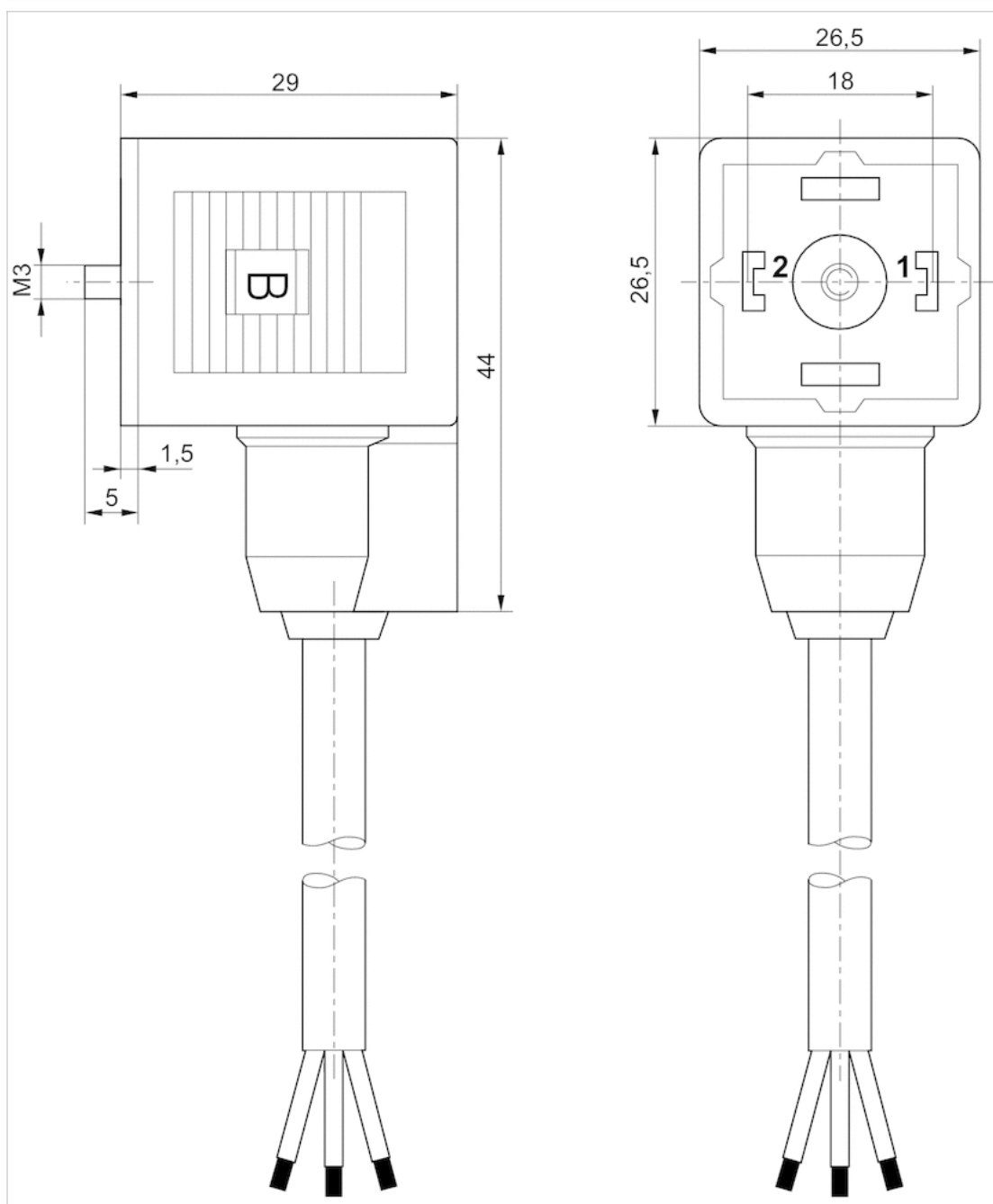
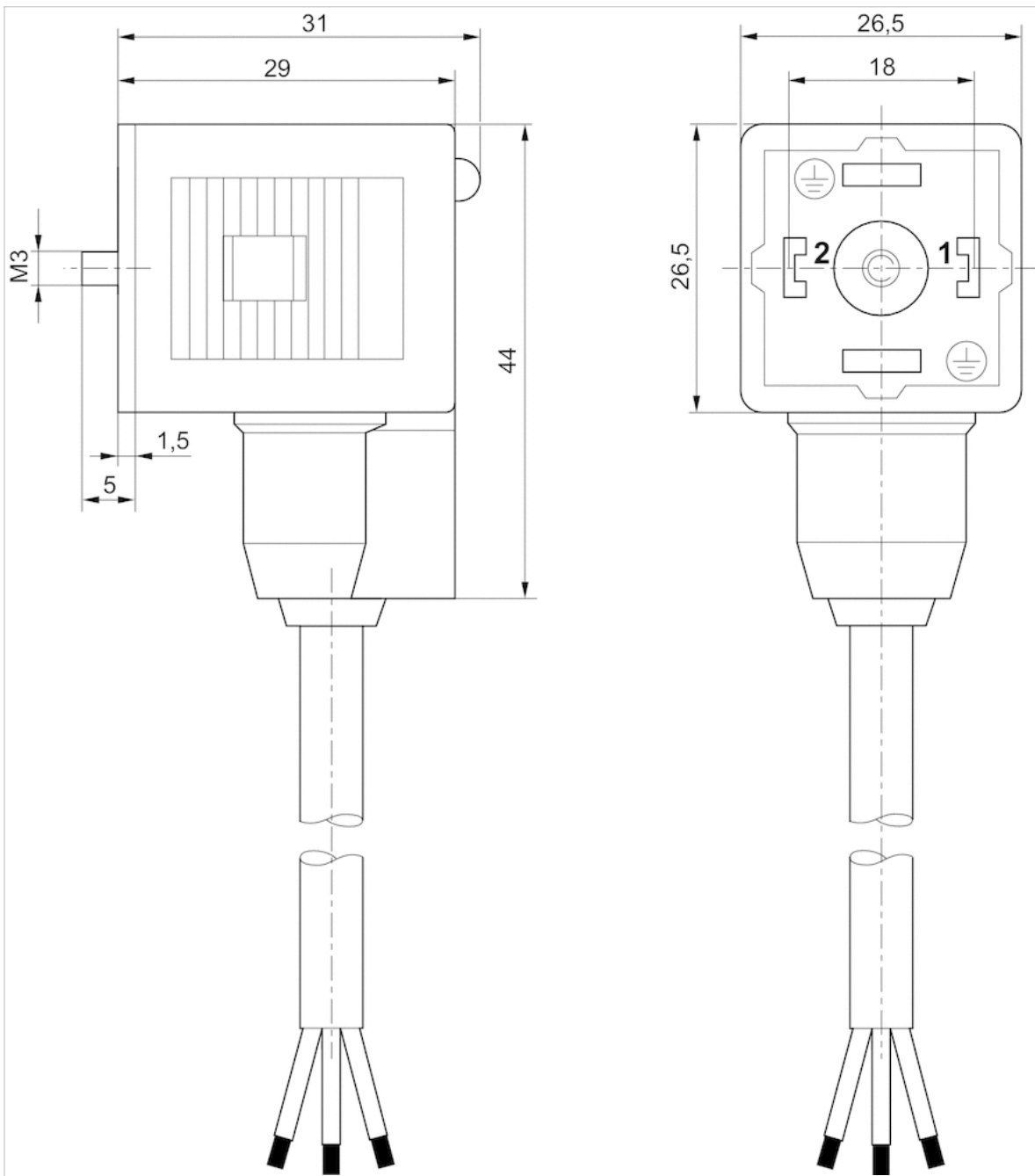
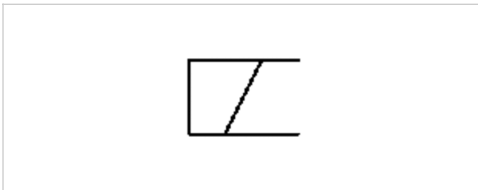

Fig. 2



Coil, Series C01

- With valve plug connector
- Coil width 30 mm
- Power consumption DC 2.1 W
- Holding power AC 4-4.1 VA
- Switch-on power AC 4-4.1 VA
- ATEX



Certificates	ATEX
ATEX class G	II 3G Ex nA IIC T4 Gc X
ATEX class D	II 3D Ex tc IIIC T125°C Dc X
Ambient temperature min./max.	-10 ... 50 °C
Protection class	IP65
Duty cycle ED	100 %
Compatibility index	13
Weight	See table below

Technical data

Part No.	Operational voltage	Operational voltage	Operational voltage
	DC	AC 50 Hz	AC 60 Hz
R412000144	24 V	-	-
R412000145	-	24 V	24 V
R412000146	-	110 V	110 V
R412000147	-	230 V	230 V

Part No.	Voltage tolerance	Voltage tolerance	Voltage tolerance	Power consumption
	DC	AC 50 Hz	AC 60 Hz	DC
R412000144	-10% / +10%	-	-	2.1 W
R412000145	-	-20% / +10%	-10% / +20%	-
R412000146	-	-20% / +10%	-10% / +20%	-
R412000147	-	-20% / +10%	-10% / +20%	-

Part No.	Holding power	Switch-on power	Weight
	AC 50 Hz	AC 50 Hz	
R412000144	-	-	0.14 kg
R412000145	4 VA	4 VA	0.134 kg
R412000146	4 VA	4 VA	0.122 kg
R412000147	4.1 VA	4.1 VA	0.137 kg

Dimensions

Dimensions

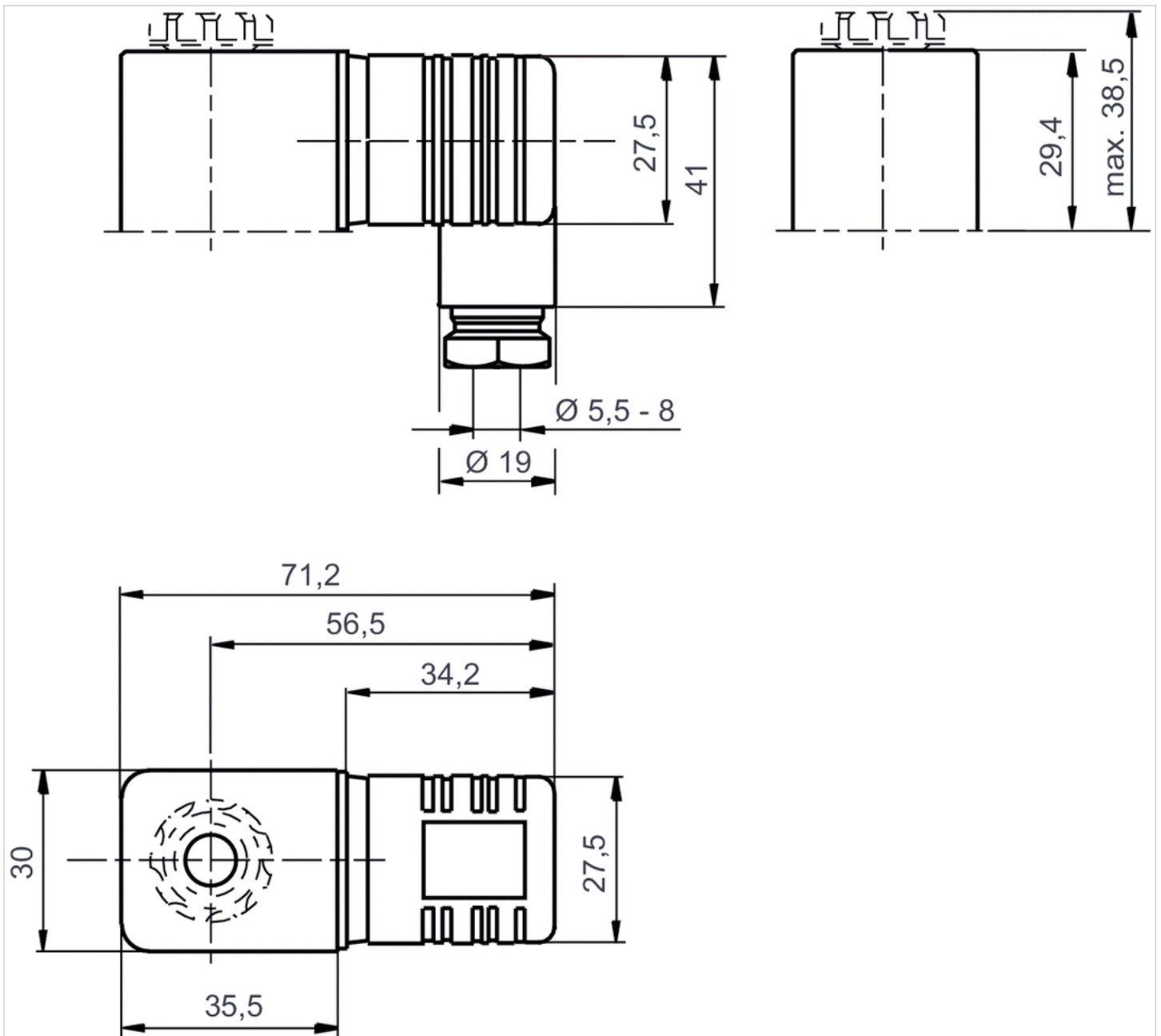

Coil, Series CO1

- Cable with valve plug connector
- Coil width 30 mm
- Power consumption DC 3.25 W
- Holding power AC 2.9-3 VA
- Switch-on power AC 3-3.1 VA
- ATEX

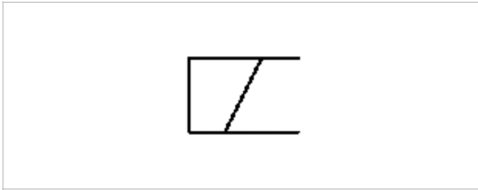

Certificates	ATEX
ATEX class G	II 2G Ex mb IIC T4 Gb
ATEX class D	II 2D Ex mb tb IIIC T130°C Db IP65
Ambient temperature min./max.	-20 ... 50 °C
Protection class	IP65
Duty cycle ED	100 %
Compatibility index	14
Weight	See table below

Technical data

Part No.	Operational voltage		Operational voltage
	DC	AC 50 Hz	AC 60 Hz
1827414297	-	230 V	230 V
1827414298	-	230 V	230 V
1827414299	-	110 V	110 V
1827414301	-	24 V	24 V
1827414303	24 V	-	-
1827414304	24 V	-	-

Part No.	Voltage tolerance		Power consumption		Holding power	
	DC	AC 50 Hz	DC	AC 50 Hz	DC	AC 50 Hz
1827414297	-	-10% / +10%	-	3 VA	-	3 VA
1827414298	-	-10% / +10%	-	3 VA	-	3 VA
1827414299	-	-10% / +10%	-	2.9 VA	-	2.9 VA
1827414301	-	-10% / +10%	-	2.9 VA	-	2.9 VA
1827414303	-10% / +10%	-	3.25 W	-	-	-
1827414304	-10% / +10%	-	3.25 W	-	-	-

Part No.	Switch-on power		Cable length	Weight
	AC 50 Hz			
1827414297	3.1 VA		3 m	0.38 kg

1827414299	3 VA	3 m	0.38 kg
1827414303	-	3 m	0.38 kg

Dimensions

Dimensions

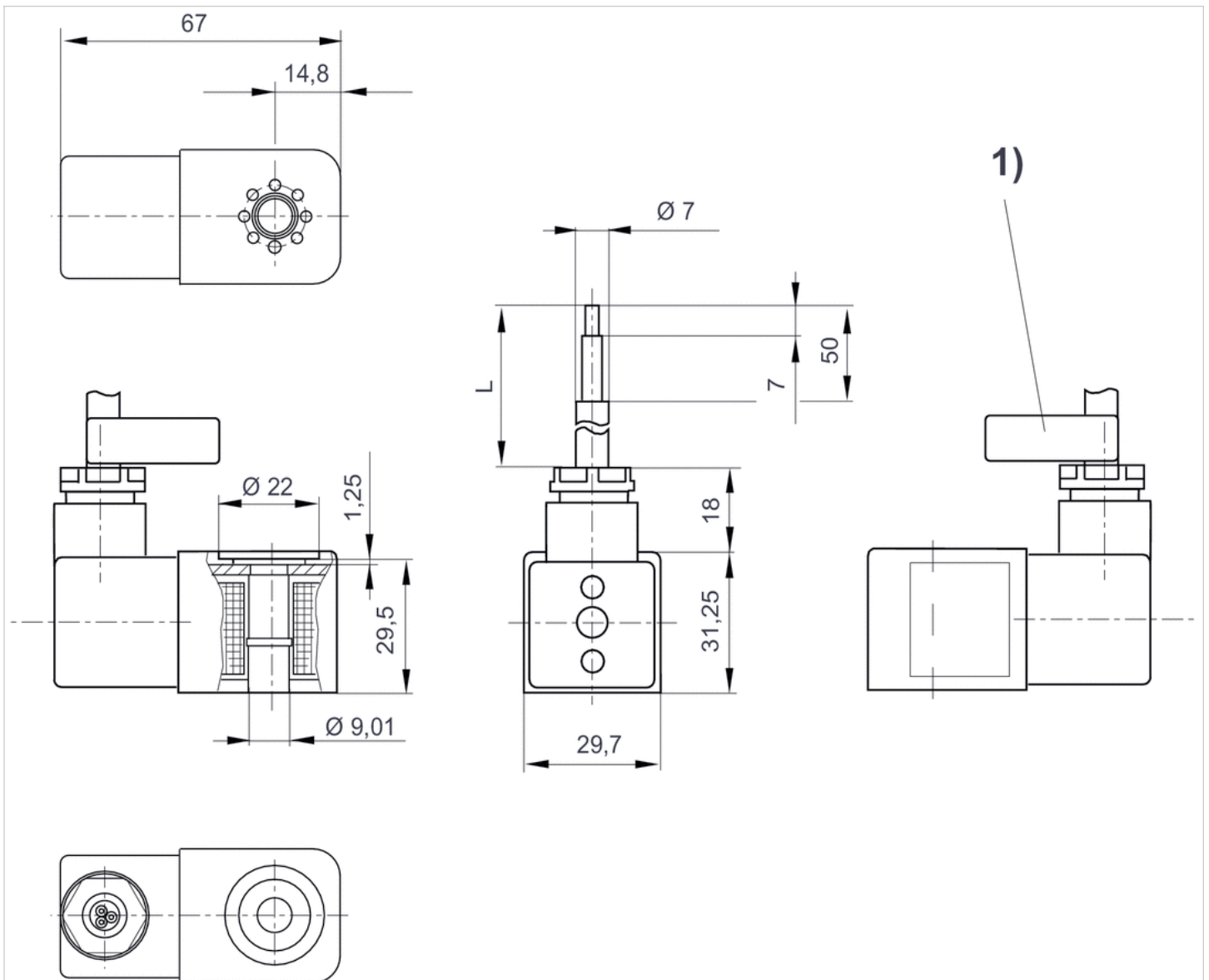

L = cable length

1) Cable ID band with serial number

Coil, Series C01

- form A
- Coil width 30 mm
- Power consumption DC 2.7 W
- Holding power AC 4.8-5.6 VA



Connector standard electrical connections	EN 175301-803, form A Plug, 3-pin
Ambient temperature min./max.	50 °C
Protection class With valve plug connector/plug	IP65
Duty cycle ED	100 %
Compatibility index	14
Weight	0.096 kg

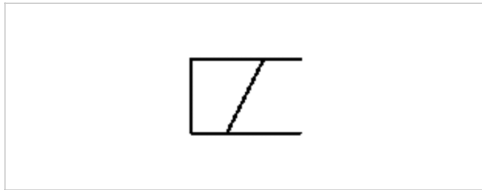

Technical data

Part No.	Operational voltage		Operational voltage
	DC	AC 50 Hz	AC 60 Hz
5420897022	24 V	-	-
5428117022	-	24 V	24 V
5428117072	-	110 V	110 V
5428117082	-	230 V	230 V

Part No.	Voltage tolerance	Voltage tolerance	Voltage tolerance	Power consumption
	DC	AC 50 Hz	AC 60 Hz	DC
5420897022	-10% / +10%	-	-	2.7 W
5428117022	-	-20% / +10%	-10% / +20%	-
5428117072	-	-20% / +10%	-10% / +20%	-
5428117082	-	-20% / +10%	-10% / +20%	-

Part No.	Holding power	
	AC 50 Hz	AC 60 Hz
5420897022	-	-
5428117022	5.2 VA	3.9 VA
5428117072	4.8 VA	3.6 VA
5428117082	5.6 VA	4.2 VA

Technical information

Material

Housing

Thermoplastic elastomer

Dimensions

Dimensions

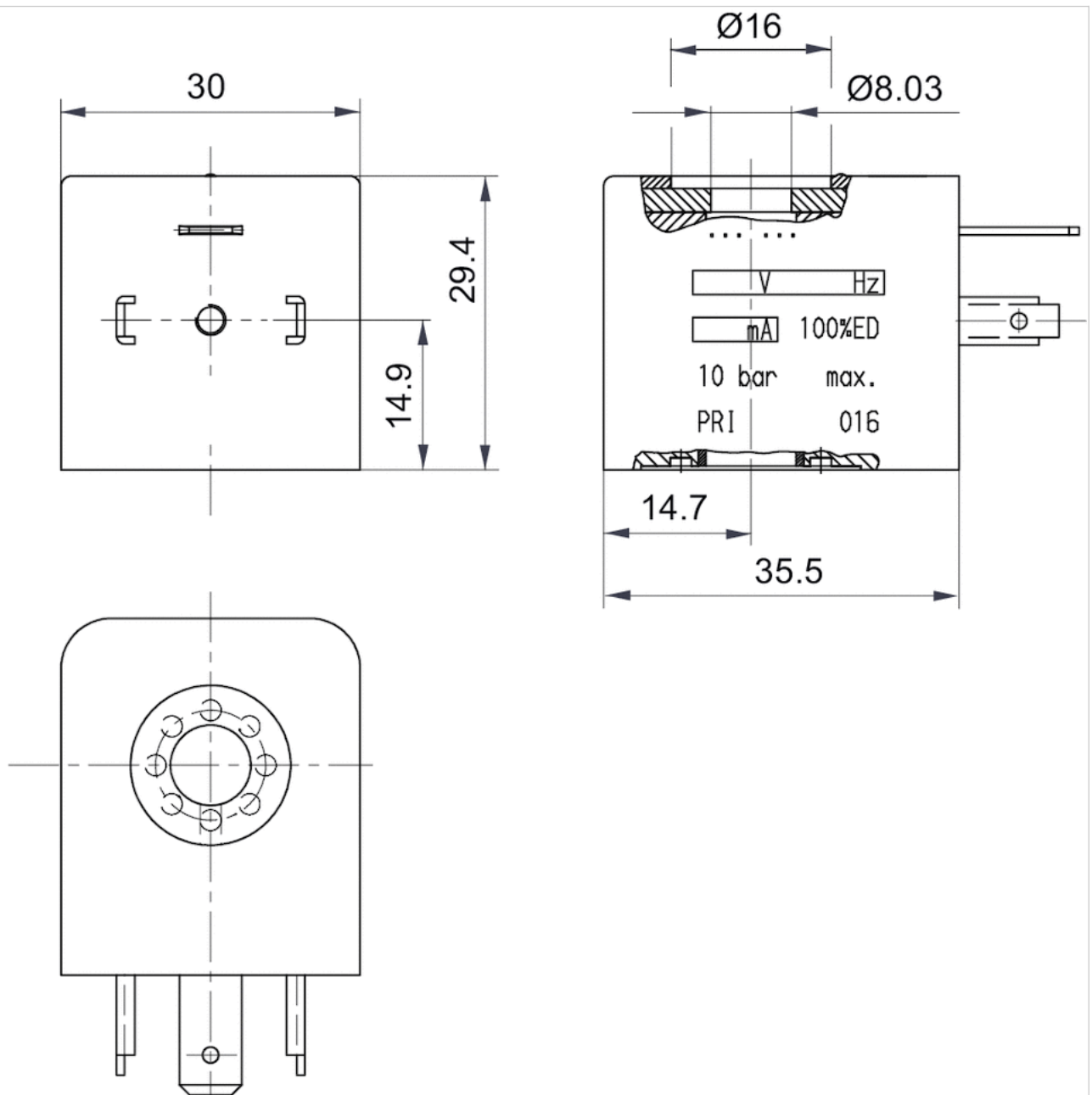

Adapter, Series CON-VP

- from form A to form C
- Socket, straight, 180°
- Plug, straight, 180°
- unshielded



Ambient temperature min./max.	-25 ... 50 °C
Operational voltage	42 V DC
Protection class	IP65
Protection class	IP65
Weight	0.013 kg

Technical data

8946053622	from form A to form C	0.5 A
------------	-----------------------	-------

Technical information

Material	
Housing	Polyamide

Dimensions

Dimensions

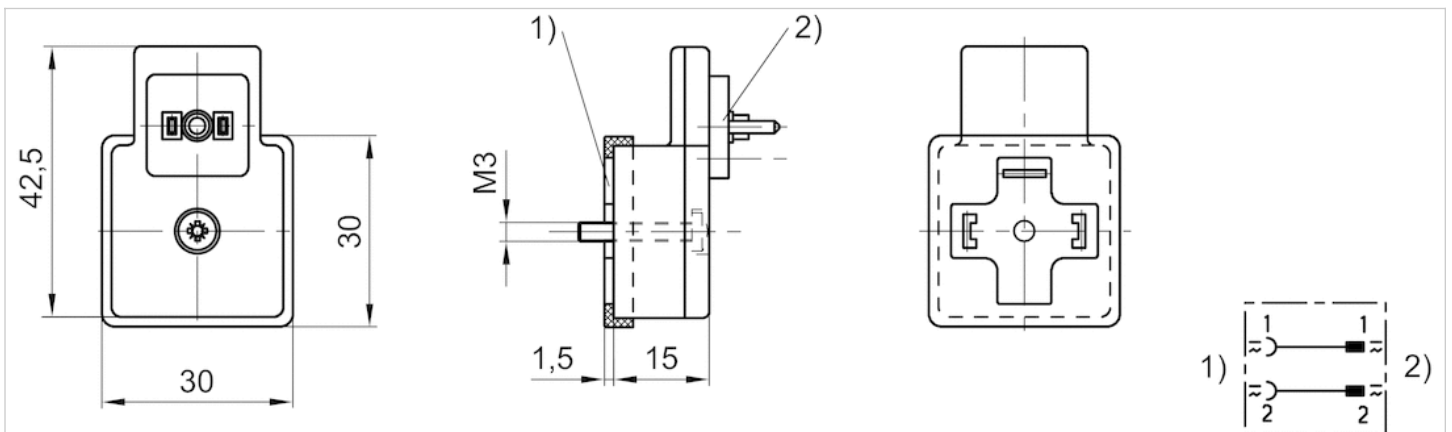

1) contact as per DIN EN 175301-803, form A
 2) contact as per DIN EN 175301-803, form C

Silencers, series SI1

- M5
- Sintered bronze



Working pressure min./max.	0 ... 10 bar
Ambient temperature min./max.	-25 ... 80 °C
Medium	Compressed air
Sound pressure level	72 dB
Weight	0.004 kg
Comment	Flow characteristic curves can be found under "Diagrams".

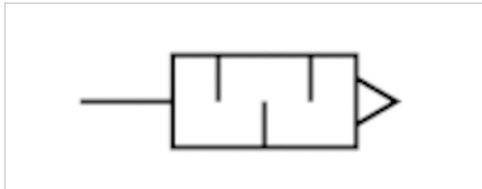

Technical data

Part No.	Compressed air connection	Flow	Delivery unit
		Qn	
1827000006	M5	398 l/min	10 piece

Weight per piece

Nominal flow Qn at p1 = 6 bar (absolute) freely discharged. Sound pressure level measured at 6 bar against atmosphere at 1 m distance.

Technical information

Material	
Silencer	Sintered bronze
Thread	Brass

Dimensions

Dimensions in mm

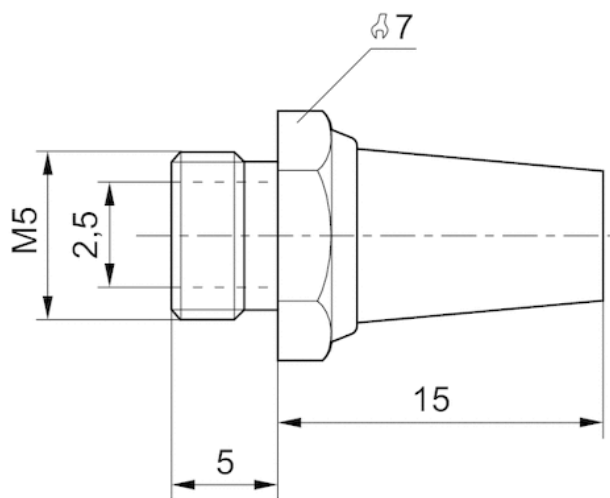

Diagrams

Flow diagram, 1827000006

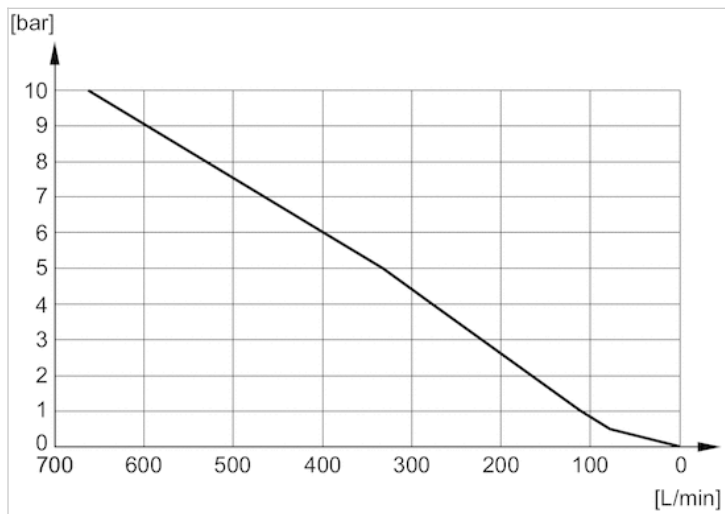

Silencers, series SI1

- M7

- Sintered bronze



Working pressure min./max.

0 ... 10 bar

Ambient temperature min./max.

-25 ... 80 °C

Medium

Compressed air

Weight

0.005 kg

Comment

Flow characteristic curves can be found under "Diagrams".

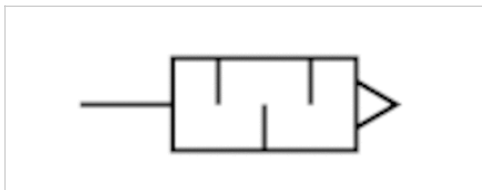

Technical data

Part No.	Compressed air connection	Delivery unit
8140000700	M7	10 piece

Weight per piece

Nominal flow Q_n at $p_1 = 6$ bar (absolute) freely discharged. Sound pressure level measured at 6 bar against atmosphere at 1 m distance.

Technical information

Material	
Silencer	Sintered bronze
Thread	Brass

Dimensions

Dimensions in mm

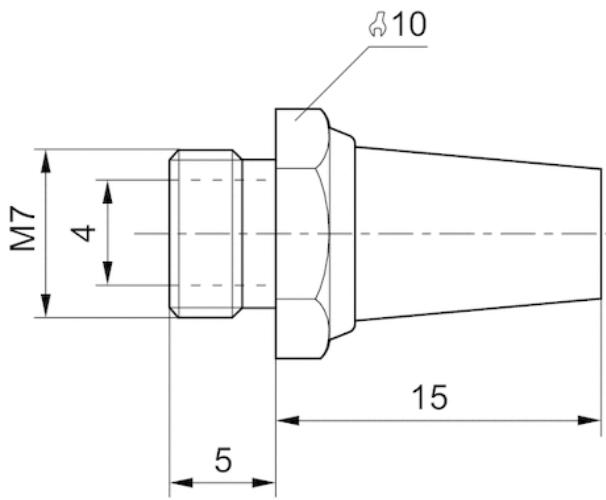

Silencers, series SI1

- M10x1

- Sintered bronze



Working pressure min./max.

0 ... 10 bar

Ambient temperature min./max.

-25 ... 80 °C

Medium

Compressed air

Sound pressure level

75 dB

Weight

0.011 kg

Comment

Flow characteristic curves can be found under "Diagrams".

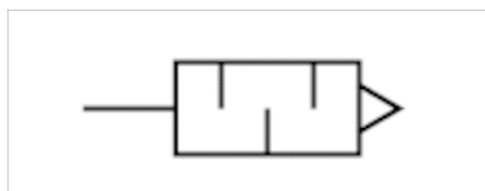

Technical data

Part No.	Compressed air connection	Flow	Delivery unit
		Qn	
5324001110	M10x1	1747 l/min	1 piece

Weight per piece

Nominal flow Qn at p1 = 6 bar (absolute) freely discharged. Sound pressure level measured at 6 bar against atmosphere at 1 m distance.

Technical information

Material	
Silencer	Sintered bronze
Thread	Brass

Dimensions

Dimensions in mm

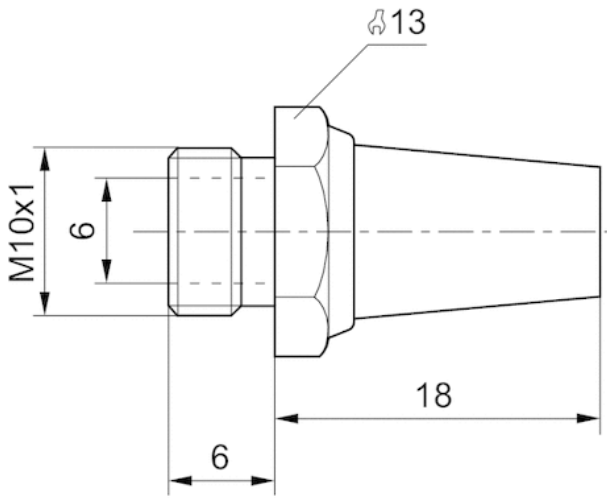

Diagrams

Flow diagram, 5324001110

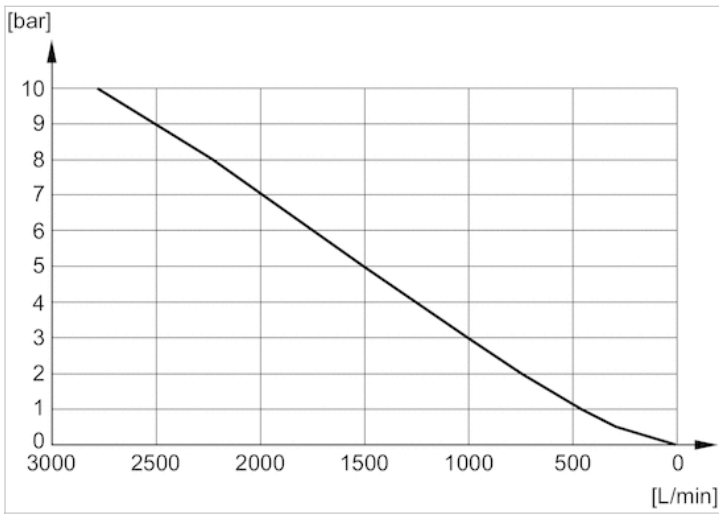

Silencers, series SI1

- M12x1,5
- Sintered bronze



Working pressure min./max.	0 ... 10 bar
Ambient temperature min./max.	-25 ... 80 °C
Medium	Compressed air
Sound pressure level	80 dB
Weight	0.019 kg
Comment	Flow characteristic curves can be found under "Diagrams".

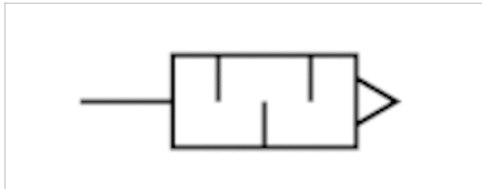

Technical data

Part No.	Compressed air connection	Flow	Delivery unit
		Qn	
5324001170	M12x1,5	3049 l/min	1 piece

Weight per piece

Nominal flow Qn at p1 = 6 bar (absolute) freely discharged. Sound pressure level measured at 6 bar against atmosphere at 1 m distance.

Technical information

Material	
Silencer	Sintered bronze
Thread	Brass

Dimensions

Dimensions in mm

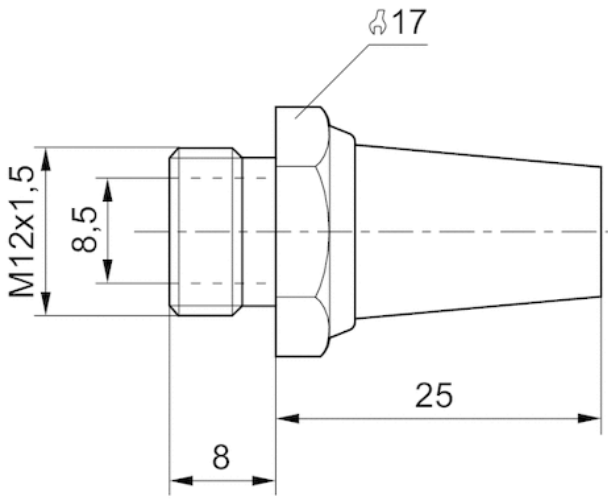

Diagrams

Flow diagram, 5324001170

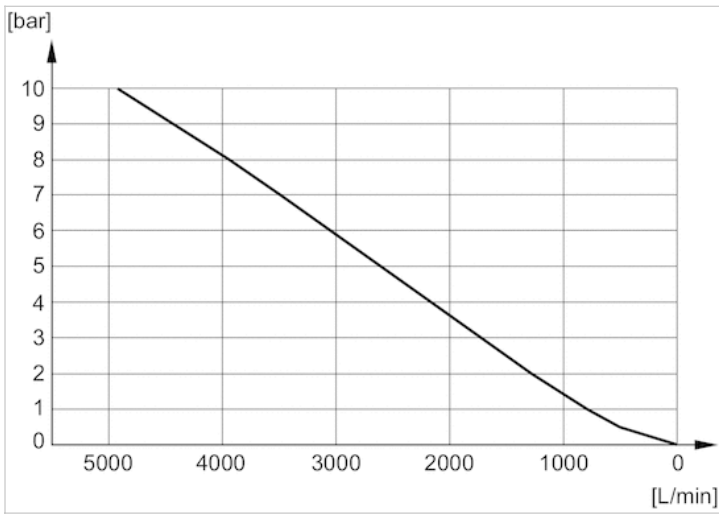

Silencers, series SI1

- M14x1,5
- Sintered bronze



Working pressure min./max.	0 ... 10 bar
Ambient temperature min./max.	-25 ... 80 °C
Medium	Compressed air
Sound pressure level	80 dB
Weight	0.018 kg
Comment	Flow characteristic curves can be found under "Diagrams".

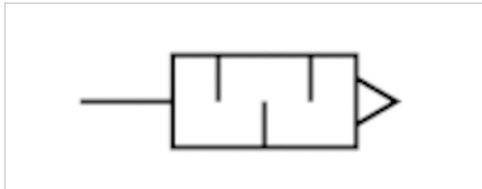

Technical data

Part No.	Compressed air connection	Flow	Delivery unit
		Qn	
5324001120	M14x1,5	3390 l/min	1 piece

Weight per piece

Nominal flow Qn at p1 = 6 bar (absolute) freely discharged. Sound pressure level measured at 6 bar against atmosphere at 1 m distance.

Technical information

Material	
Silencer	Sintered bronze
Thread	Brass

Dimensions

Dimensions in mm

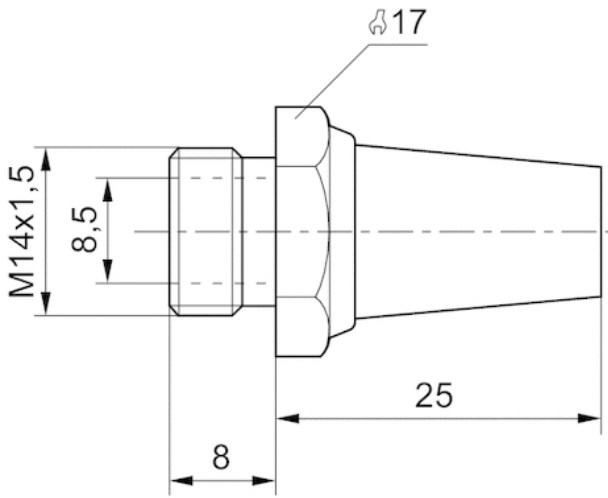

Diagrams

Flow diagram, 5324001120

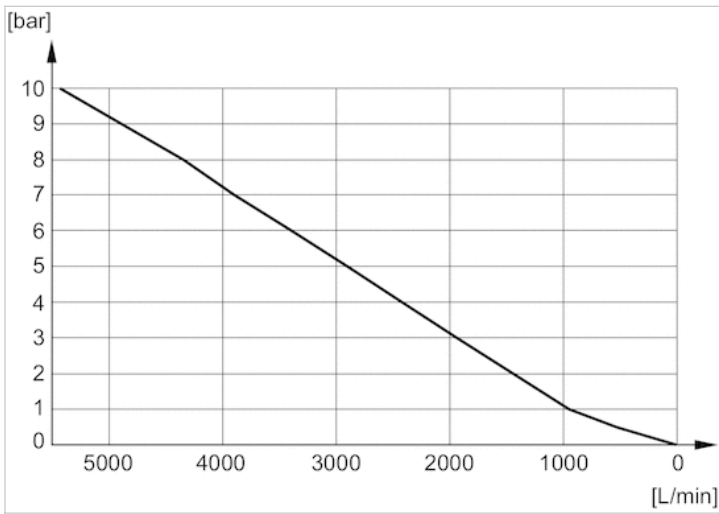

Silencers, series SI1

- M22x1,5
- Sintered bronze



Working pressure min./max.	0 ... 10 bar
Ambient temperature min./max.	-25 ... 80 °C
Medium	Compressed air
Sound pressure level	85 dB
Weight	0.071 kg
Comment	Flow characteristic curves can be found under "Diagrams".

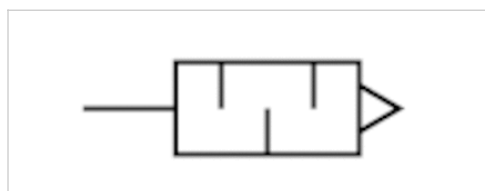

Technical data

Part No.	Compressed air connection	Flow	Delivery unit
		Qn	
5324001140	M22x1,5	7223 l/min	1 piece

Weight per piece

Nominal flow Qn at p1 = 6 bar (absolute) freely discharged. Sound pressure level measured at 6 bar against atmosphere at 1 m distance.

Technical information

Material	
Silencer	Sintered bronze
Thread	Brass

Dimensions

Dimensions in mm

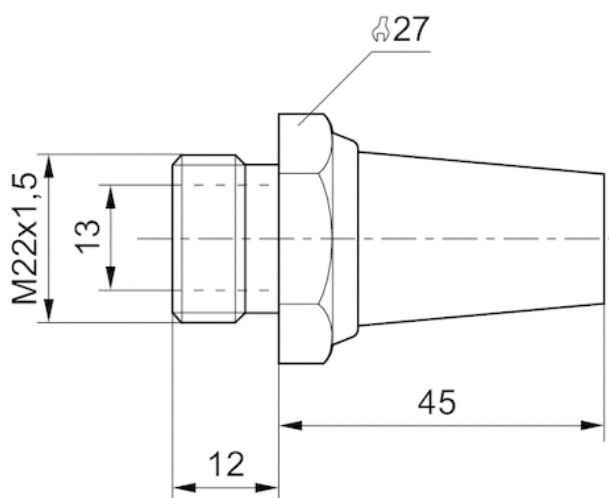

Diagrams

Flow diagram, 5324001140

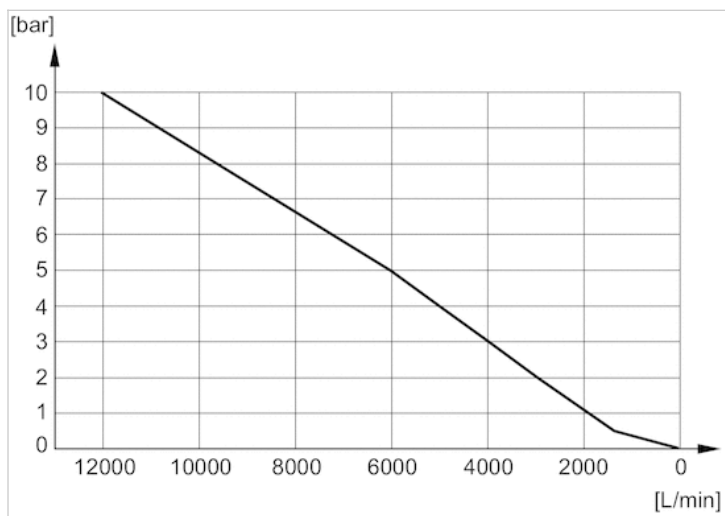

Silencers, series SI1

- G 1/8
- Sintered bronze



Working pressure min./max.	0 ... 10 bar
Ambient temperature min./max.	-25 ... 80 °C
Medium	Compressed air
Sound pressure level	75 dB
Weight	0.01 kg
Comment	Flow characteristic curves can be found under "Diagrams".

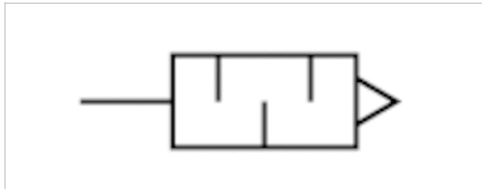

Technical data

Part No.	Compressed air connection	Flow	Delivery unit
		Qn	
1827000000	G 1/8	1623 l/min	10 piece

Weight per piece

Nominal flow Qn at p1 = 6 bar (absolute) freely discharged. Sound pressure level measured at 6 bar against atmosphere at 1 m distance.

Technical information

Material	
Silencer	Sintered bronze
Thread	Brass

Dimensions

Dimensions in mm

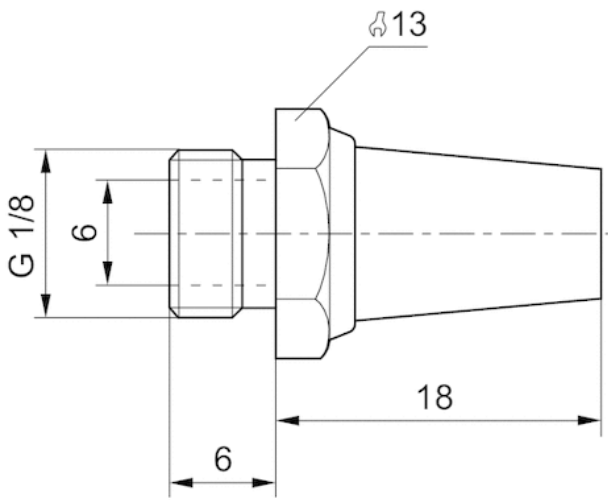

Diagrams

Flow diagram, 1827000000

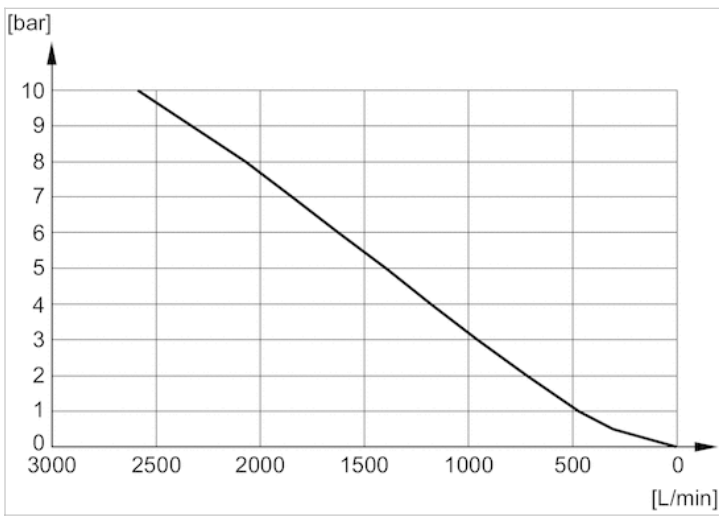

Silencers, series SI1

- G 1/4
- Sintered bronze



Working pressure min./max.	0 ... 10 bar
Ambient temperature min./max.	-25 ... 80 °C
Medium	Compressed air
Sound pressure level	See table below
Weight	See table below
Comment	Flow characteristic curves can be found under "Diagrams".

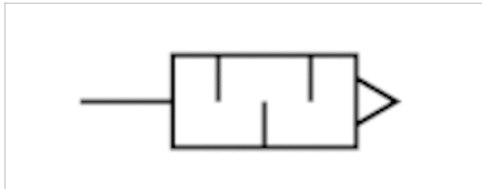

Technical data

Part No.	Compressed air connection	Sound pressure level	Flow	Delivery unit	Weight
			Qn		
R412004817	G 1/4	-	5950 l/min	10 piece	0.013 kg
1827000001	G 1/4	79 dB	3390 l/min	10 piece	0.02 kg

Weight per piece

Nominal flow Qn at p1 = 6 bar (absolute) freely discharged. Sound pressure level measured at 6 bar against atmosphere at 1 m distance.

Technical information

Material	
Silencer	Sintered bronze
Thread	Brass

Dimensions

Dimensions in mm

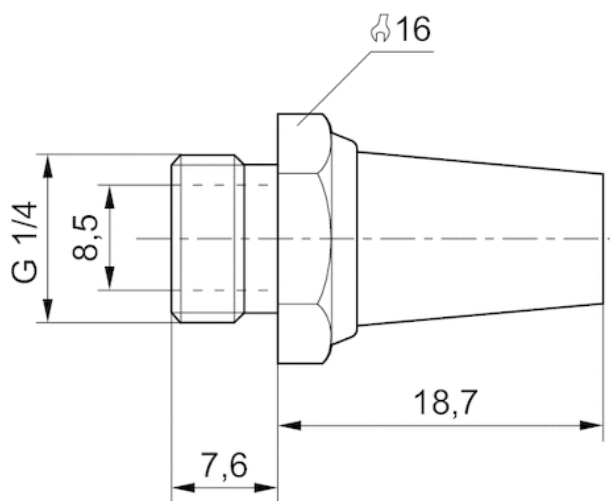

Dimensions in mm

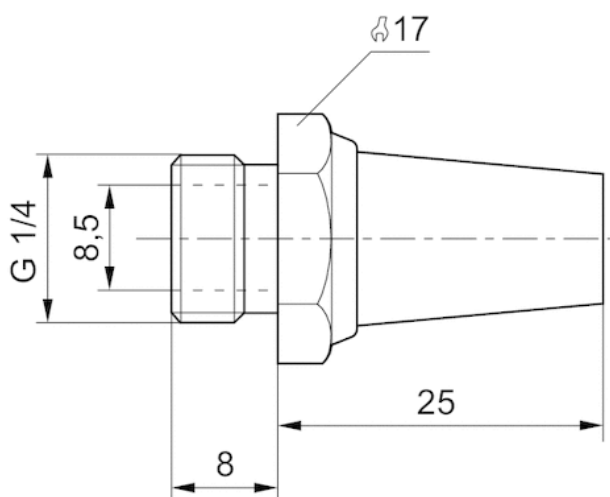

Silencers, series SI1

- G 3/8
- Sintered bronze



Working pressure min./max.	0 ... 10 bar
Ambient temperature min./max.	-25 ... 80 °C
Medium	Compressed air
Sound pressure level	84 dB
Weight	0.05 kg
Comment	Flow characteristic curves can be found under "Diagrams".

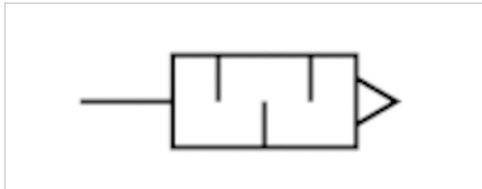

Technical data

Part No.	Compressed air connection	Flow	Delivery unit
		Qn	
1827000002	G 3/8	6554 l/min	5 piece

Weight per piece

Nominal flow Qn at p1 = 6 bar (absolute) freely discharged. Sound pressure level measured at 6 bar against atmosphere at 1 m distance.

Technical information

Material	
Silencer	Sintered bronze
Thread	Brass

Dimensions

Dimensions in mm

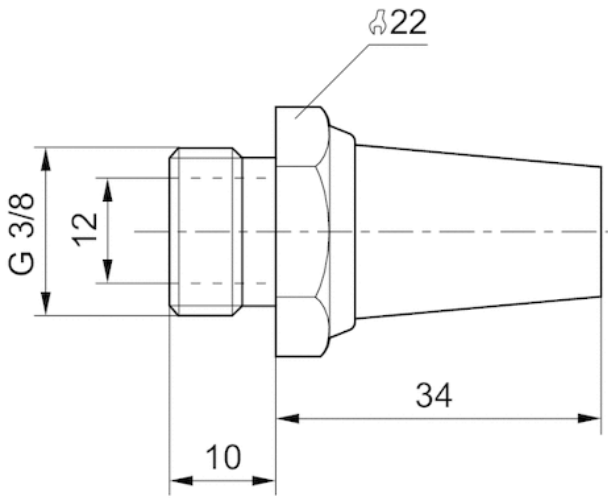

Diagrams

Flow diagram, 1827000002

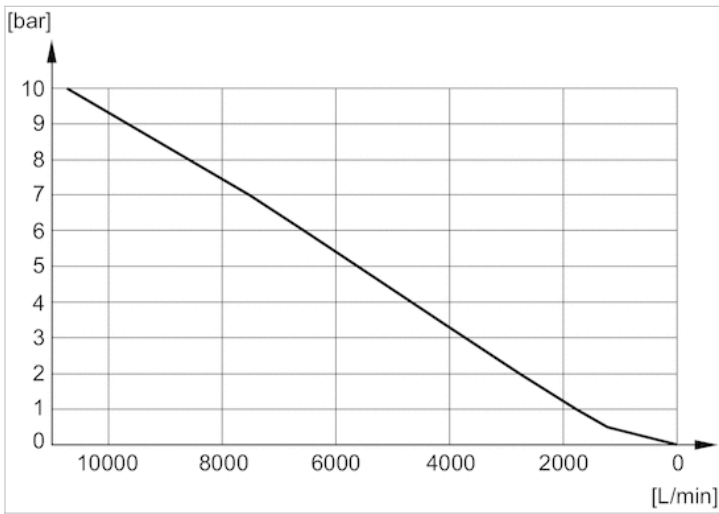

Silencers, series SI1

- G 1/2
- Sintered bronze



Working pressure min./max.	0 ... 10 bar
Ambient temperature min./max.	-25 ... 80 °C
Medium	Compressed air
Sound pressure level	90 dB
Weight	0.08 kg
Comment	Flow characteristic curves can be found under "Diagrams".

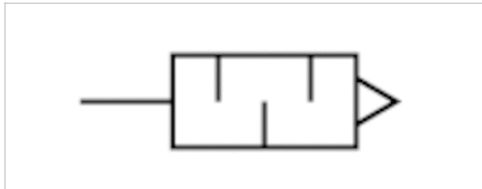

Technical data

Part No.	Compressed air connection	Flow	Delivery unit
		Qn	
1827000003	G 1/2	7223 l/min	2 piece

Weight per piece

Nominal flow Qn at p1 = 6 bar (absolute) freely discharged. Sound pressure level measured at 6 bar against atmosphere at 1 m distance.

Technical information

Material	
Silencer	Sintered bronze
Thread	Brass

Dimensions

Dimensions in mm

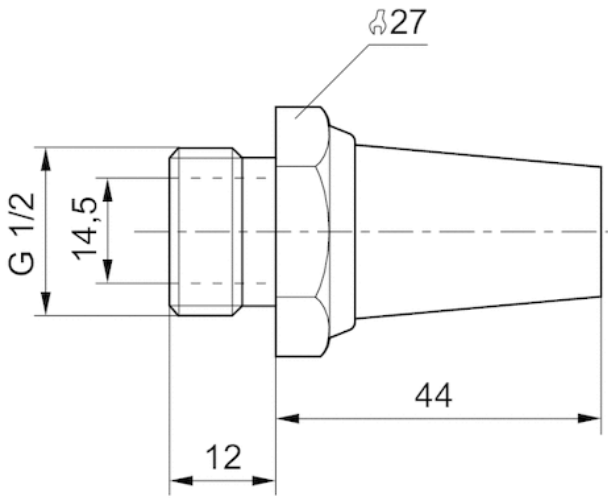

Diagrams

Flow diagram, 1827000003

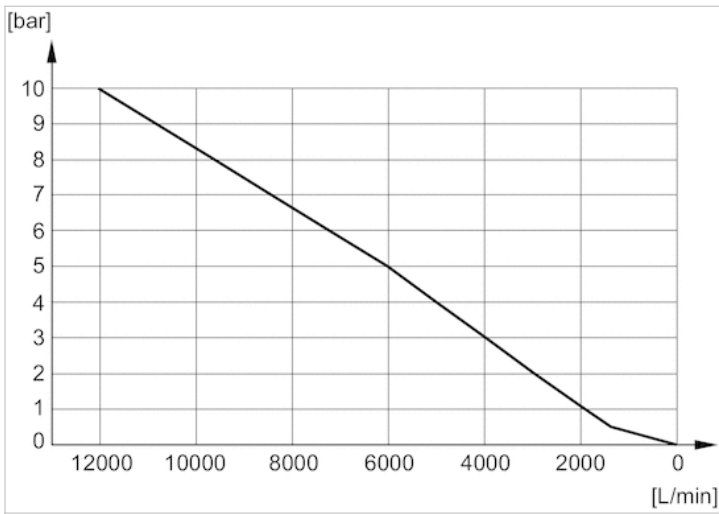

Silencers, series SI1

- G 3/4
- Sintered bronze



Working pressure min./max.	0 ... 10 bar
Ambient temperature min./max.	-25 ... 80 °C
Medium	Compressed air
Sound pressure level	92 dB
Weight	0.13 kg
Comment	Flow characteristic curves can be found under "Diagrams".

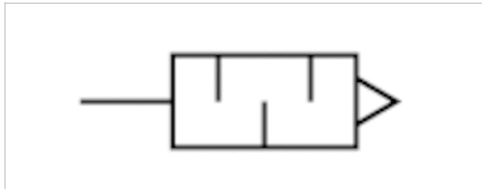

Technical data

Part No.	Compressed air connection	Flow	Delivery unit
		Qn	
1827000004	G 3/4	8394 l/min	1 piece

Weight per piece

Nominal flow Qn at p1 = 6 bar (absolute) freely discharged. Sound pressure level measured at 6 bar against atmosphere at 1 m distance.

Technical information

Material	
Silencer	Sintered bronze
Thread	Brass

Dimensions

Dimensions in mm

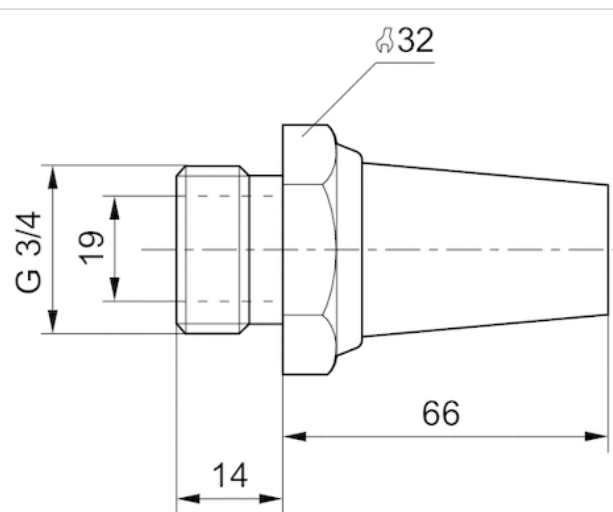

Diagrams

Flow diagram, 1827000004

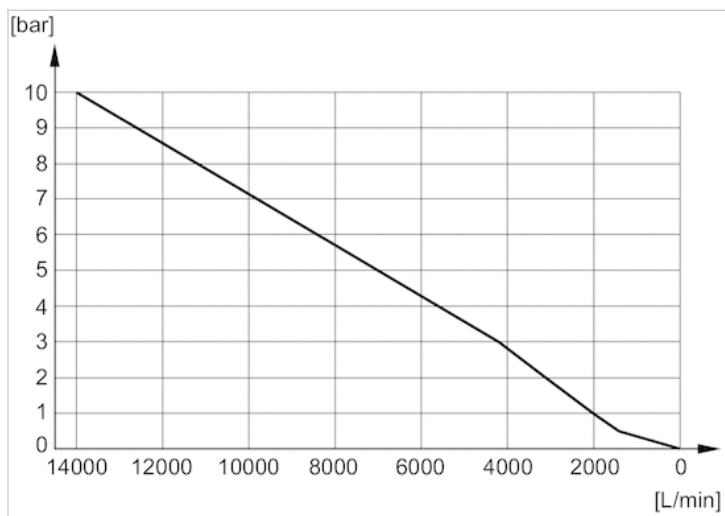

Silencers, series SI1

- G 1
- Sintered bronze



Working pressure min./max.	0 ... 10 bar
Ambient temperature min./max.	-25 ... 80 °C
Medium	Compressed air
Sound pressure level	102 dB
Weight	0.18 kg
Comment	Flow characteristic curves can be found under "Diagrams".

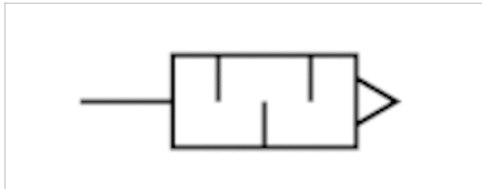

Technical data

Part No.	Compressed air connection	Flow	Delivery unit
		Qn	
1827000005	G 1	12848 l/min	1 piece

Weight per piece

Nominal flow Qn at p1 = 6 bar (absolute) freely discharged. Sound pressure level measured at 6 bar against atmosphere at 1 m distance.

Technical information

Material	
Silencer	Sintered bronze
Thread	Brass

Dimensions

Dimensions in mm

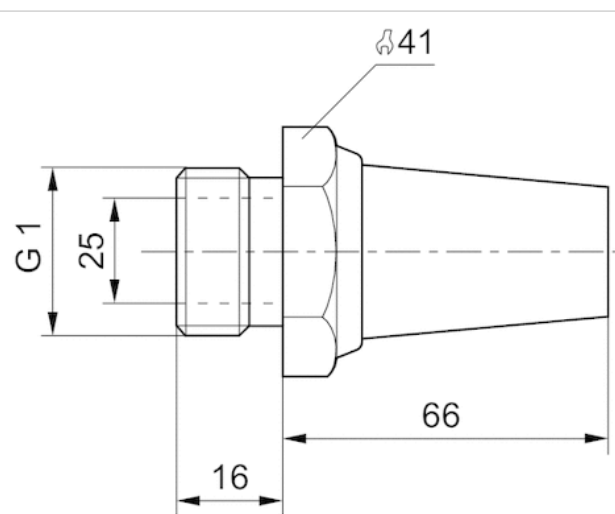

Diagrams

Flow diagram, 1827000005

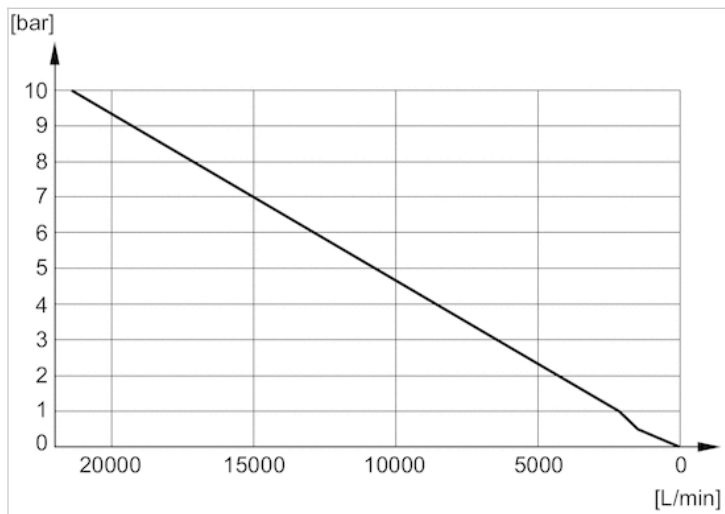

Silencers, series SI1

- M5 G 1/8 G 1/4 G 3/8 G 1/2 G 3/4 G 1

- Sintered bronze

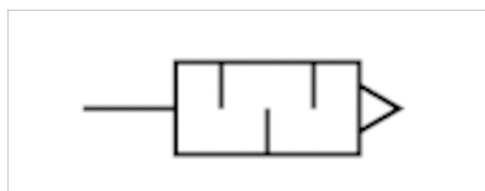

Working pressure min./max.

0 ... 10 bar

Ambient temperature min./max.

-25 ... 80 °C

Medium

Compressed air

Sound pressure level

See table below

Weight

See table below

Comment

Flow characteristic curves can be found under "Diagrams".

Technical data

Part No.	Compressed air connection	Sound pressure level	Flow	Delivery unit	Weight
			Qn		
1827000032	M5	79 dB	252 l/min	10 piece	0.005 kg
1827000031	G 1/8	85 dB	700 l/min	10 piece	0.001 kg
1827000033	G 1/4	88 dB	1116 l/min	10 piece	0.01 kg
1827000034	G 3/8	90 dB	1706 l/min	5 piece	0.016 kg
1827000035	G 1/2	85 dB	2568 l/min	2 piece	0.035 kg
8145003400	G 3/4	82 dB	3260 l/min	1 piece	0.095 kg
8145001000	G 1	82 dB	9485 l/min	1 piece	0.057 kg

Weight per piece

Nominal flow Qn at p1 = 6 bar (absolute) freely discharged. Sound pressure level measured at 6 bar against atmosphere at 1 m distance.

Technical information

Material	
Silencer	Sintered bronze
Thread	Brass

Dimensions

Dimensions

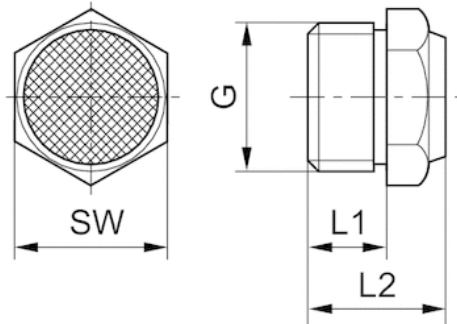

Dimensions

1827000032	M5	5	10.3	7
1827000033	G 1/4	8	13.5	17
1827000035	G 1/2	12	19.5	27
8145001000	G 1	16	22.5	41

Sound pressure level measured at 6 bar at 1 m distance

Diagrams

Flow diagram, 1827000032

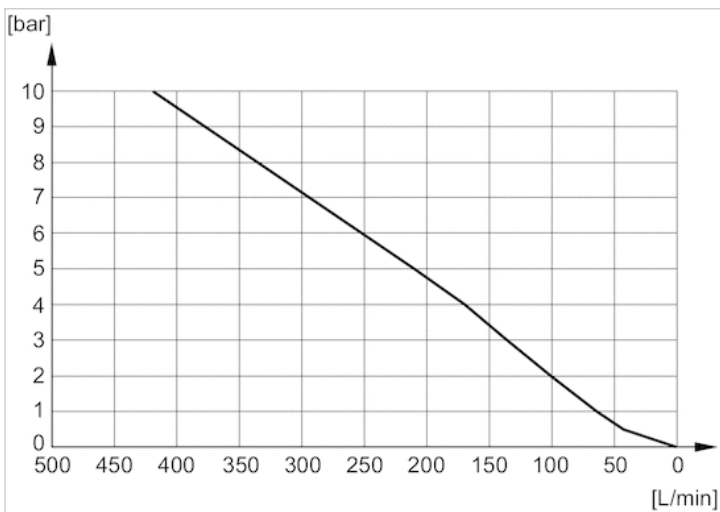

Flow diagram, 1827000031

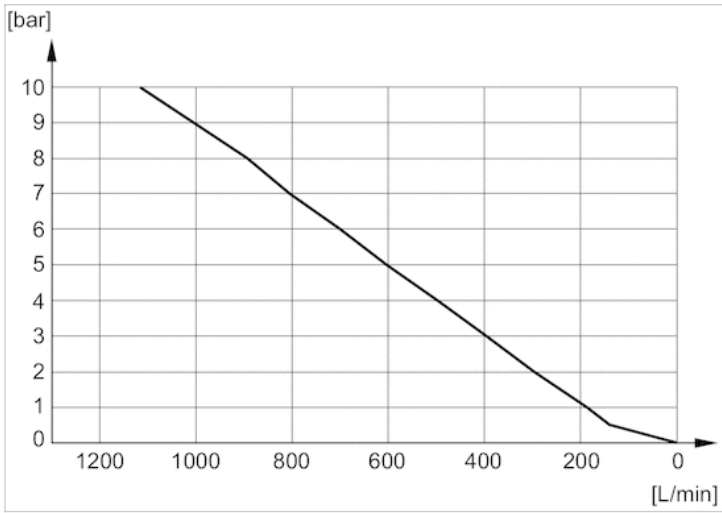

Flow diagram, 1827000033

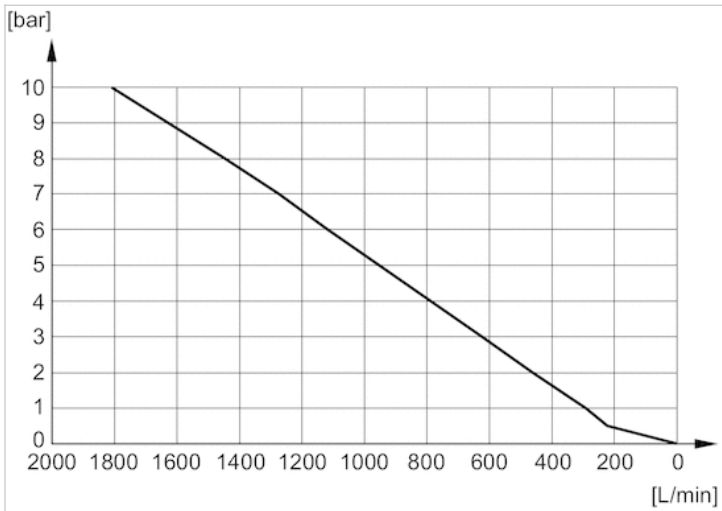

Flow diagram, 1827000034

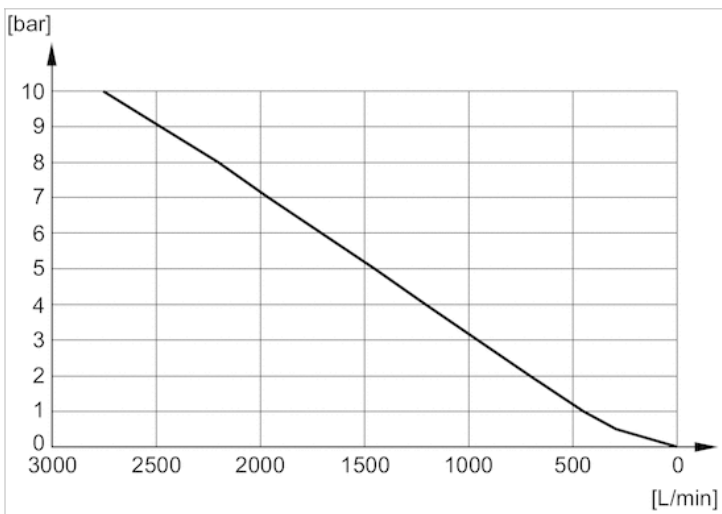

Flow diagram, 1827000035

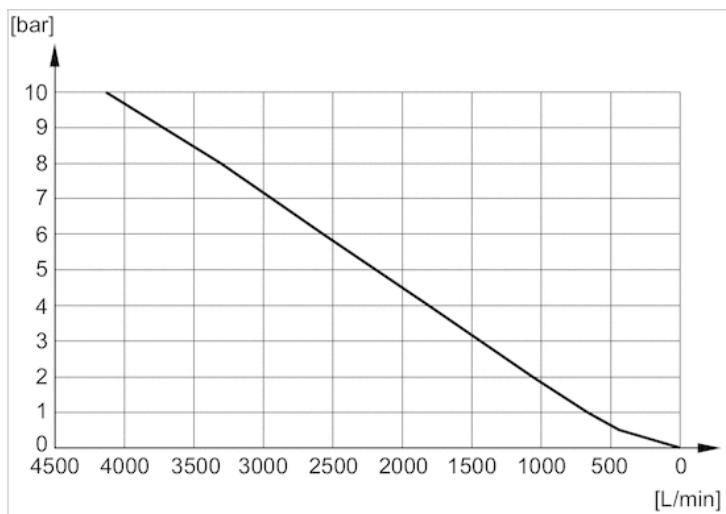

Flow diagram, 8145003400

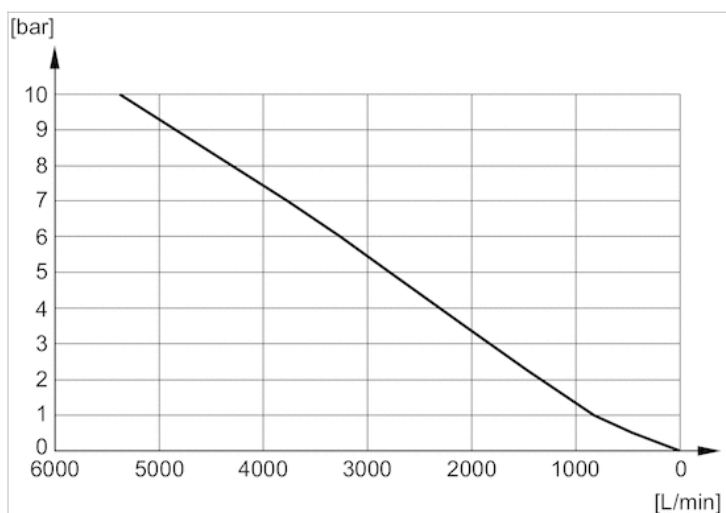

Flow diagram, 8145001000

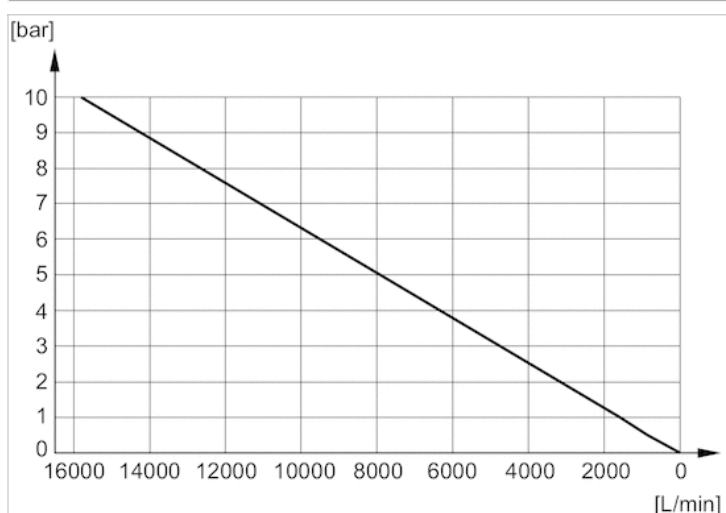

Silencers, series SI1

- G 1/8 G 1/4 G 3/8 G 1/2 G 3/4 G 1

- Sintered bronze



Working pressure min./max.

0 ... 10 bar

Ambient temperature min./max.

-25 ... 80 °C

Medium

Compressed air

Comment

Flow characteristic curves can be found under "Diagrams".

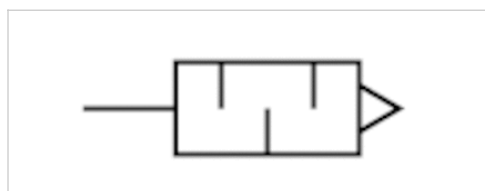

Technical data

Part No.	Compressed air connection	Flow	Delivery unit
		Qn	
1827430004	G 1/8	311 l/min	10 piece
R414000155	G 1/4	553 l/min	10 piece
R412007875	G 3/8	743 l/min	5 piece
R412007876	G 1/2	1343 l/min	2 piece
R412007877	G 3/4	3585 l/min	2 piece
R412007878	G 1	5012 l/min	2 piece

Nominal flow Qn at p1 = 6 bar (absolute) freely discharged. Sound pressure level measured at 6 bar against atmosphere at 1 m distance.

Technical information

Material	
Silencer	Sintered bronze
Thread	Brass

Dimensions

Dimensions

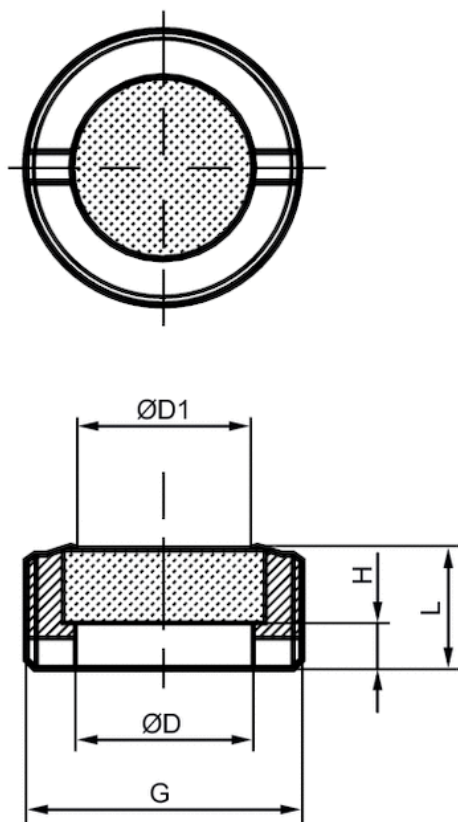

Dimensions

Part No.	Port G	$\varnothing D$	$\varnothing D1$	H	L
1827430004	G 1/8	6	5	2	4
R414000155	G 1/4	8	6	3	6
R412007875	G 3/8	10	8	3	7
R412007876	G 1/2	15	12	5	9
R412007877	G 3/4	20	17	3.4	8
R412007878	G 1	26	23	5.5	9.5

Diagrams

Flow diagram, 1827430004

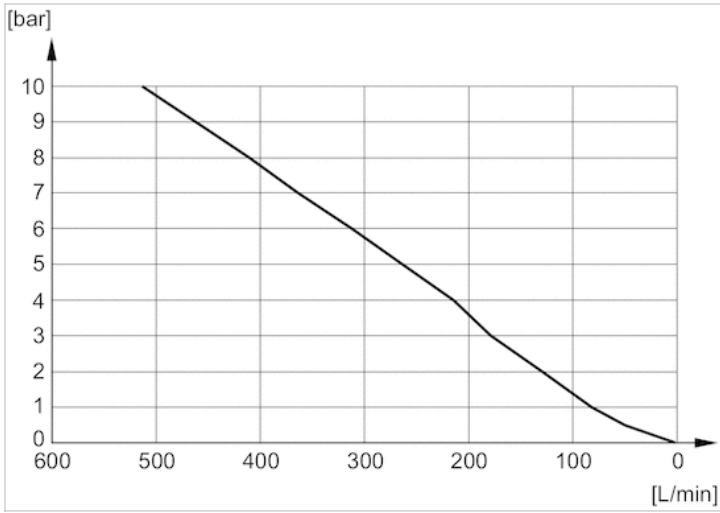

Flow diagram, R414000155

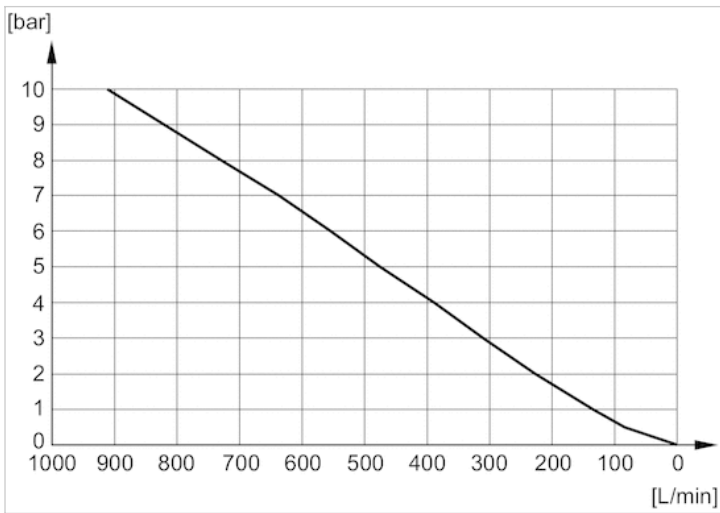

R412007875

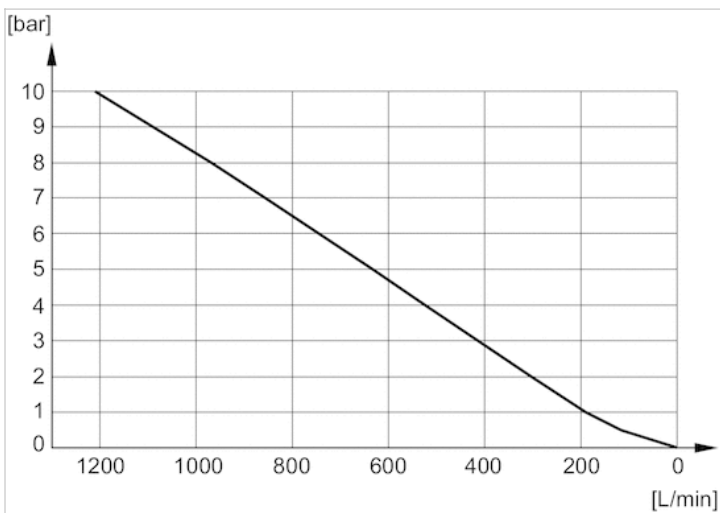

Flow diagram, R412007876

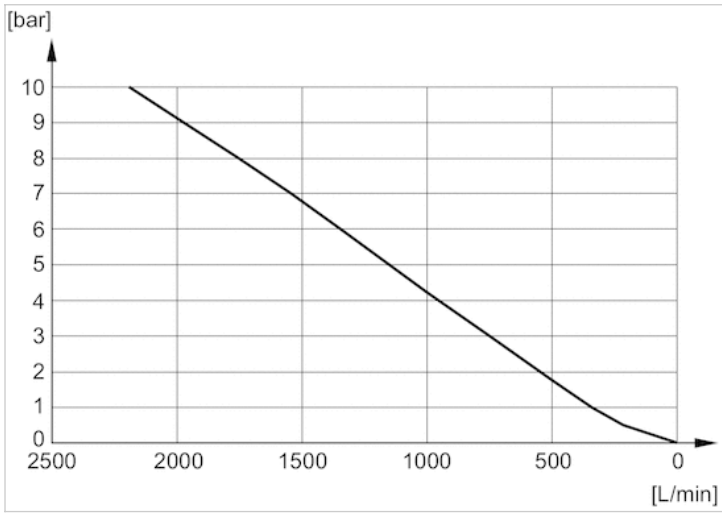

Flow diagram, R412007877

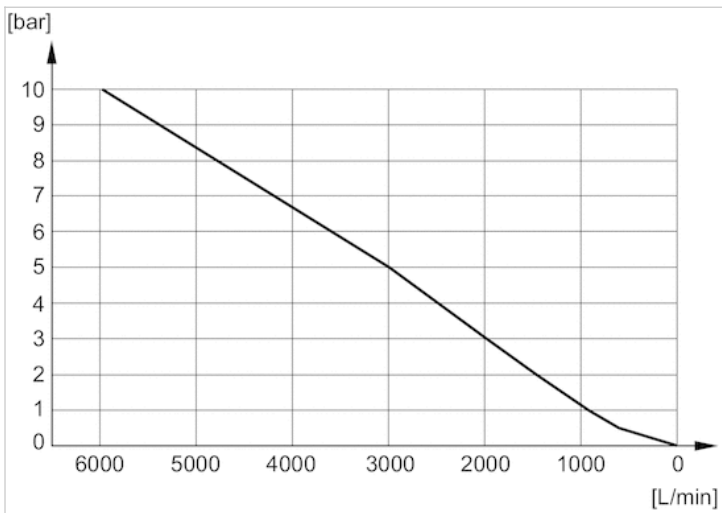

Flow diagram, R412007878

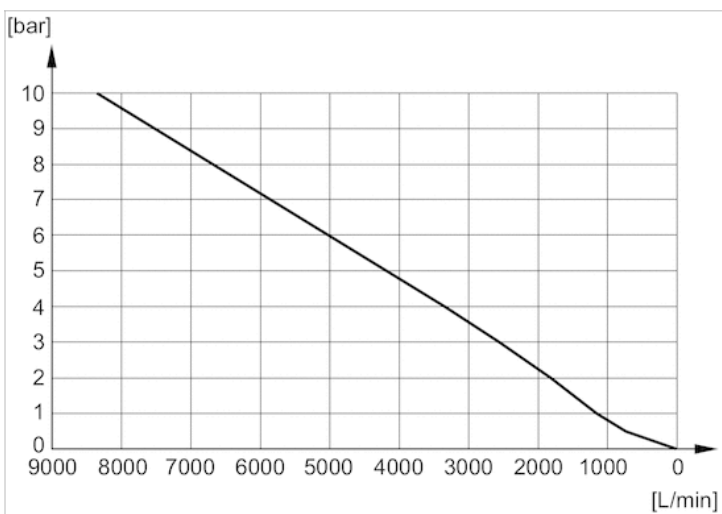

Silencers, series SI1

- M5 G 1/8 G 1/4 G 3/8 G 1/2 G 3/4 G 1

- Stainless steel



Working pressure min./max.

0 ... 12 bar

Ambient temperature min./max.

-20 ... 150 °C

Medium

Compressed air

Sound pressure level

See table below

Weight

See table below

Comment

Flow characteristic curves can be found under "Diagrams".

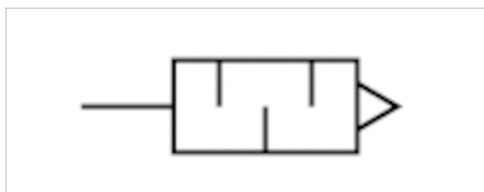

Technical data

Part No.	Compressed air connection	Sound pressure level	Flow	Delivery unit	Weight
			Qn		
R412010090	M5	85 dB	73 l/min	1 piece	0.003 kg
R412010081	G 1/8	90 dB	1312 l/min	1 piece	0.011 kg
R412010082	G 1/4	93 dB	1852 l/min	1 piece	0.021 kg
R412010083	G 3/8	101 dB	2678 l/min	1 piece	0.028 kg
R412010084	G 1/2	95 dB	5649 l/min	1 piece	0.048 kg
R412010085	G 3/4	110 dB	5945 l/min	1 piece	0.076 kg
R412010086	G 1	100 dB	7206 l/min	1 piece	0.099 kg

Weight per piece

Nominal flow Qn at p1 = 6 bar (absolute) freely discharged. Sound pressure level measured at 6 bar against atmosphere at 1 m distance.

Technical information

Material	
Silencer	Stainless steel
Thread	Stainless steel

Dimensions

Dimensions

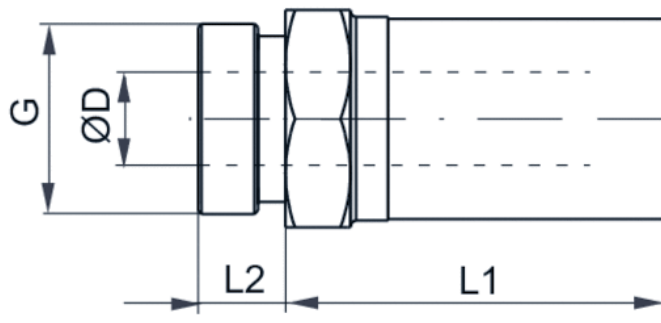

Dimensions

Part Number	Thread	ØD [mm]	L2 [mm]	L1 [mm]	G [mm]
R412010090	M5	8	3.1	10.5	3.5
R412010082	G 1/4	16	8.6	29.5	7.5
R412010084	G 1/2	24	15.3	39.5	9.5
R412010086	G 1	36	25.5	49.5	11.5

Diagrams

Flow diagram, R412010090

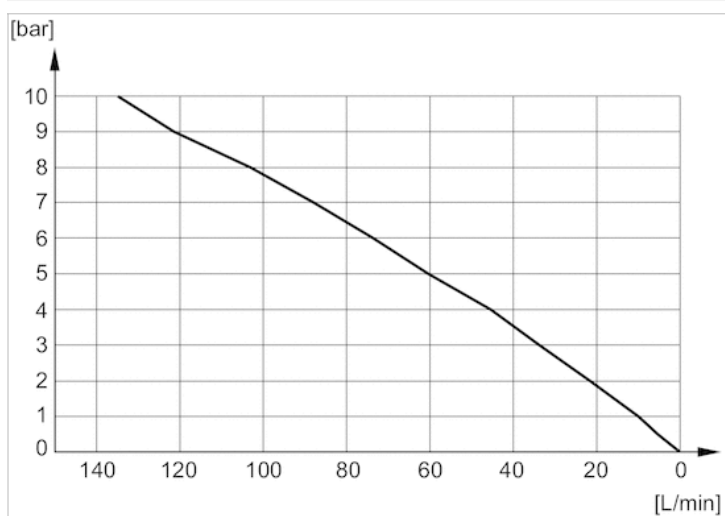

Flow diagram, R412010081

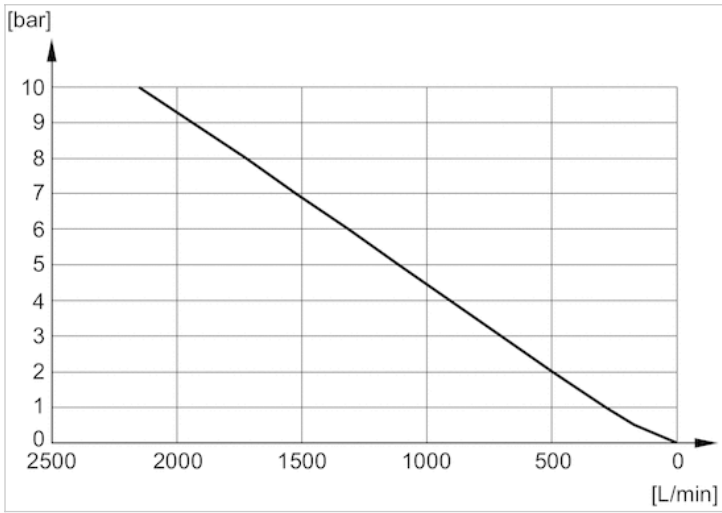

Flow diagram, R412010082

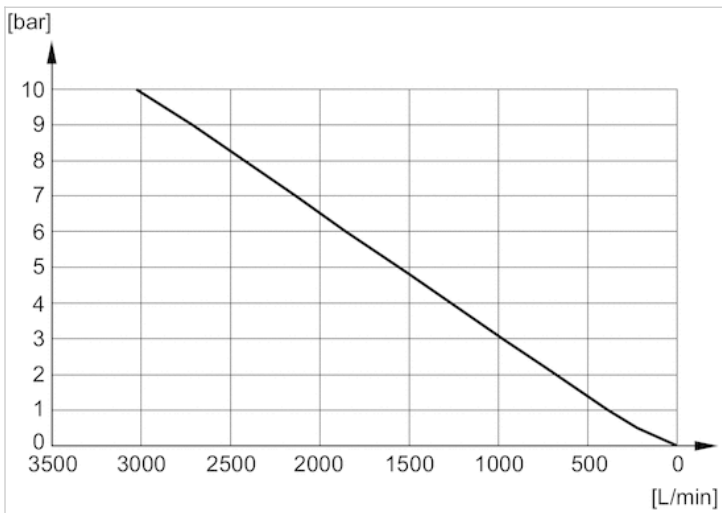

Flow diagram, R412010083

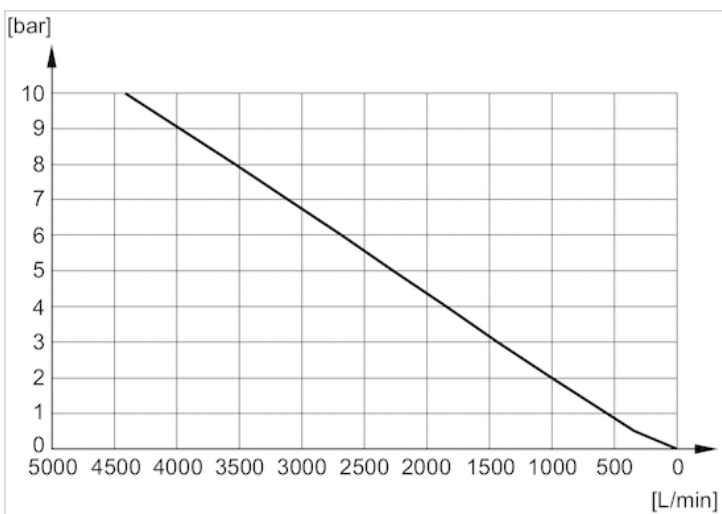

Flow diagram, R412010084

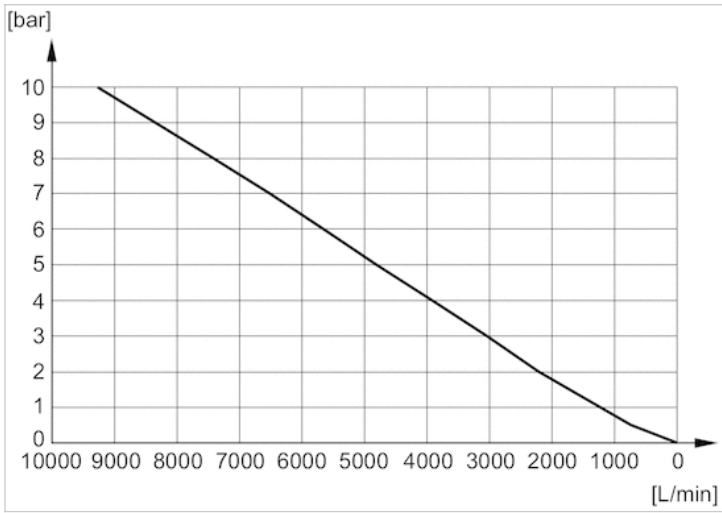

Flow diagram, R412010085

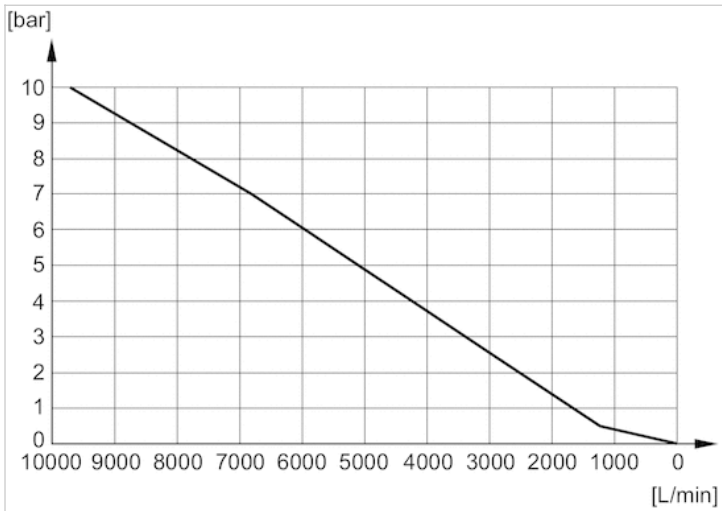

Flow diagram, R412010086

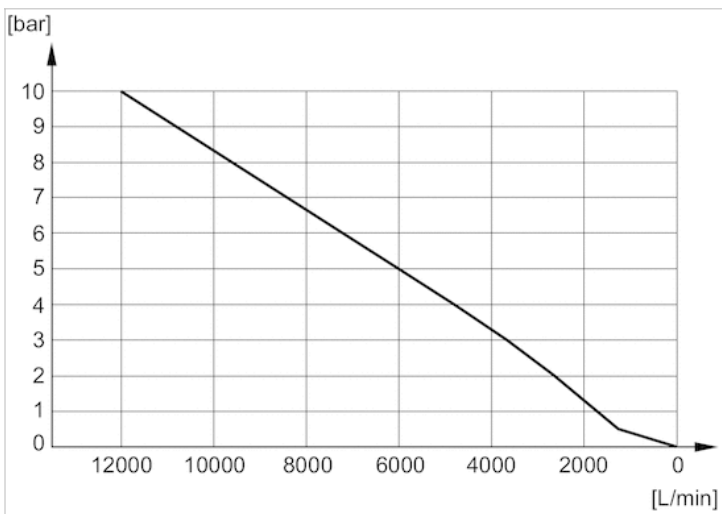

Silencers, series SI1

- M5 G 1/8 G 1/4 G 3/8 G 1/2 G 3/4 G 1

- Polyethylene

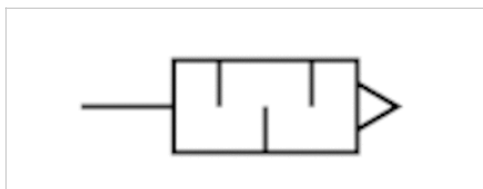

Working pressure min./max.	0 ... 10 bar
Ambient temperature min./max.	-25 ... 80 °C
Medium	Compressed air
Sound pressure level	See table below
Weight	See table below

Technical data

Part No.	Compressed air connection	Sound pressure level	Flow	Delivery unit	Weight
			Qn		
1827000018	M5	-	381 l/min	5 piece	0.001 kg
1827000019	G 1/8	78 dB	1560 l/min	5 piece	0.002 kg
1827000020	G 1/4	80 dB	3447 l/min	5 piece	0.003 kg
1827000021	G 3/8	85 dB	5682 l/min	2 piece	0.008 kg
1827000022	G 1/2	88 dB	7142 l/min	1 piece	0.013 kg
1827000023	G 3/4	-	8356 l/min	1 piece	0.04 kg
1827000024	G 1	-	13329 l/min	1 piece	0.055 kg

Weight per piece

Nominal flow Qn at p1 = 6 bar (absolute) freely discharged. Sound pressure level measured at 6 bar against atmosphere at 1 m distance.

Technical information

Flow characteristic curves can be found under "Diagrams".

Technical information

Material	
Silencer	Polyethylene
Thread	Polyethylene

Dimensions

Dimensions

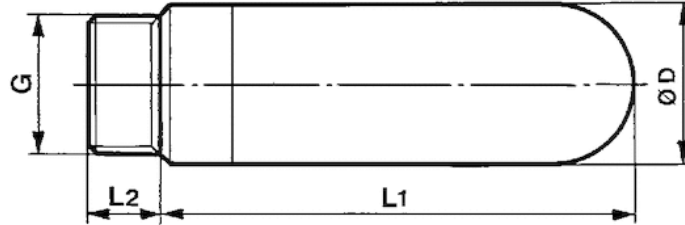

Dimensions

1827000018	M5	6.5	17.5	4
1827000020	G 1/4	15.5	34.5	8
1827000022	G 1/2	23.3	66.5	11
1827000024	G 1	49	140	21

Diagrams

Flow diagram, 1827000018

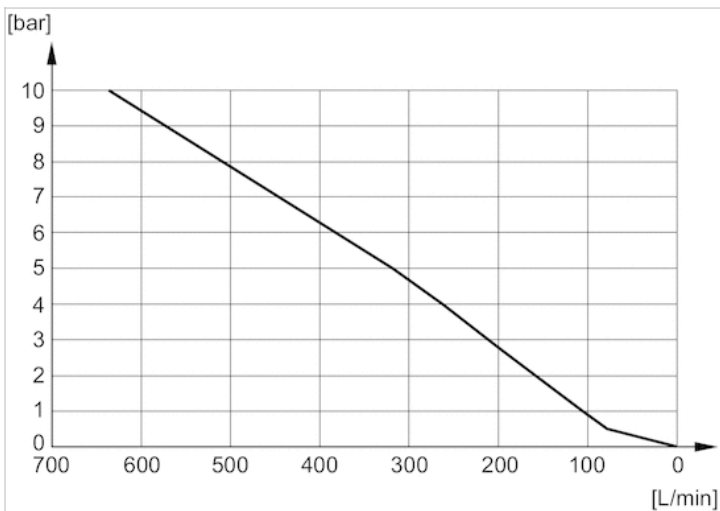

Flow diagram, 1827000019

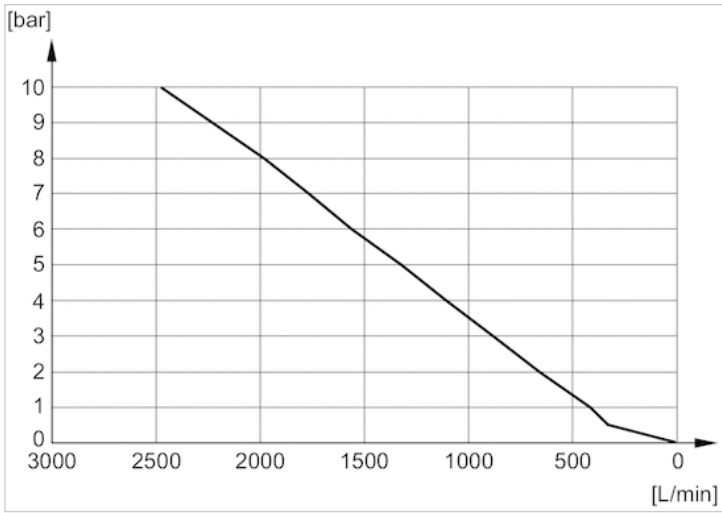

Flow diagram, 1827000020

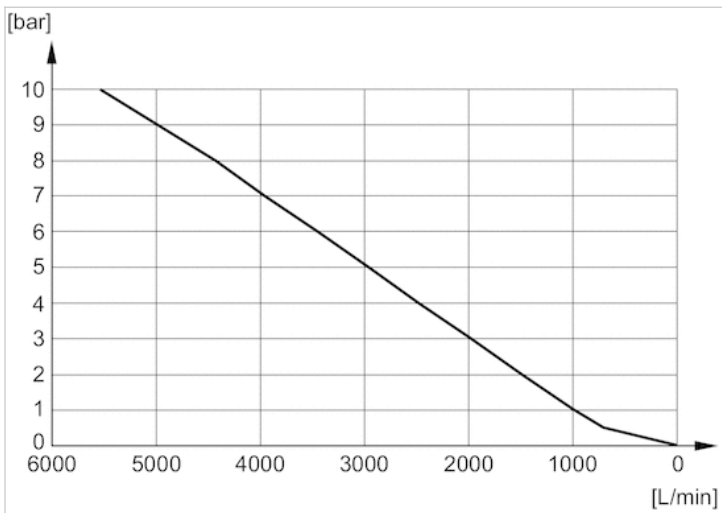

Flow diagram, 1827000021

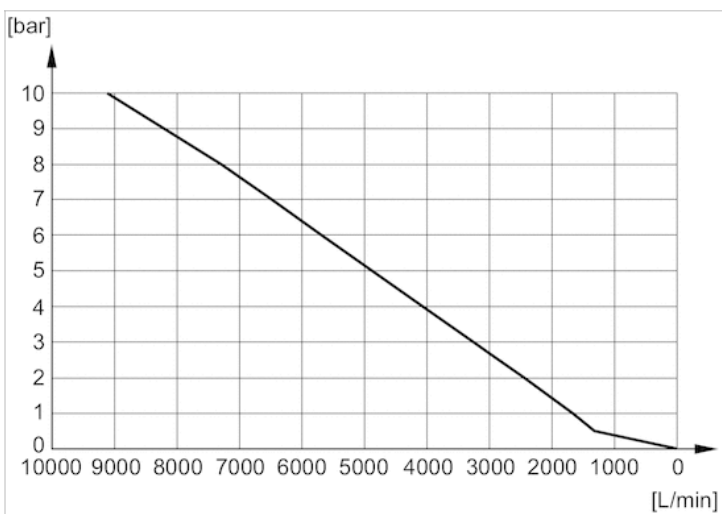

Flow diagram, 1827000022

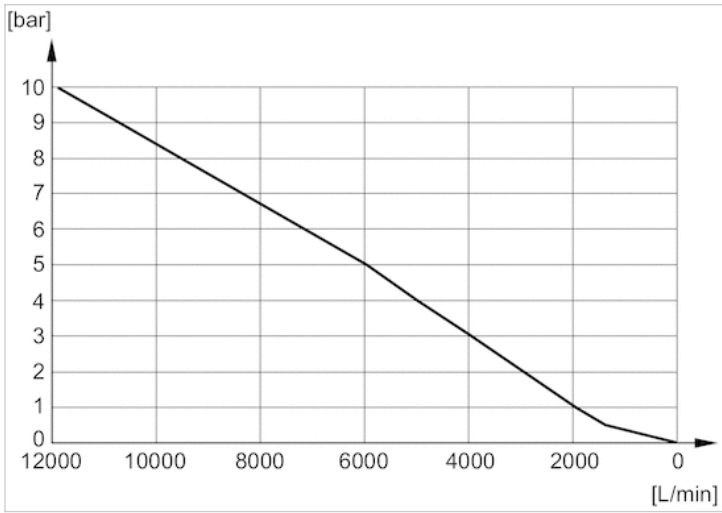

Flow diagram, 1827000023

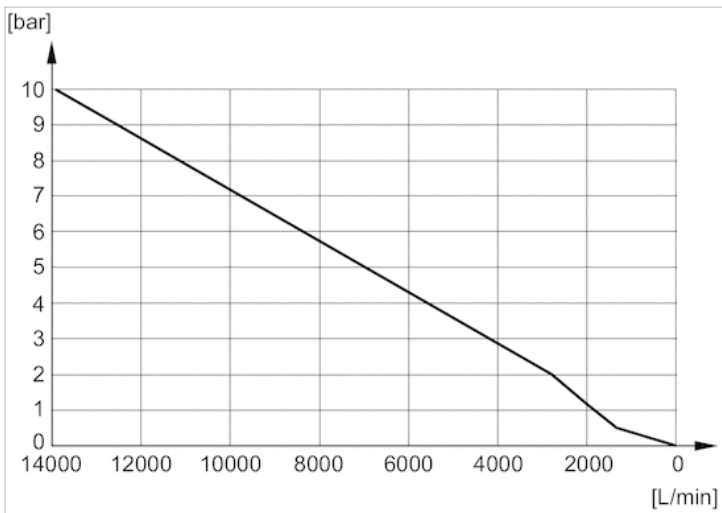

Flow diagram, 1827000024

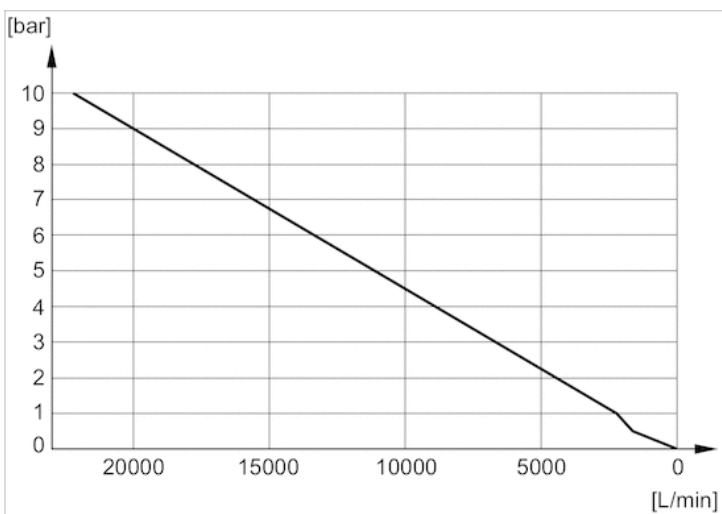

Blanking plate, for series CD07



Working pressure min./max.	-0.95 ... 16 bar
Ambient temperature min./max.	-25 ... 80 °C
Medium temperature min./max.	-25 ... 80 °C
Medium	Compressed air
Number of valve positions max.	1
Weight	0.181 kg

Technical data

Part No.
3354601024

Technical information

The min. control pressure must be adhered to, since otherwise faulty switching and valve failure may result!
 The pressure dew point must be at least 15 °C under ambient and medium temperature and may not exceed 3 °C .
 The oil content of compressed air must remain constant during the life cycle.
 Use only the approved oils from AVENTICS. Further information can be found in the "Technical information" document (available in the MediaCentre).

Technical information

Material	
Base plate	Aluminum
Seal	Acrylonitrile butadiene rubber

Dimensions

Dimensions

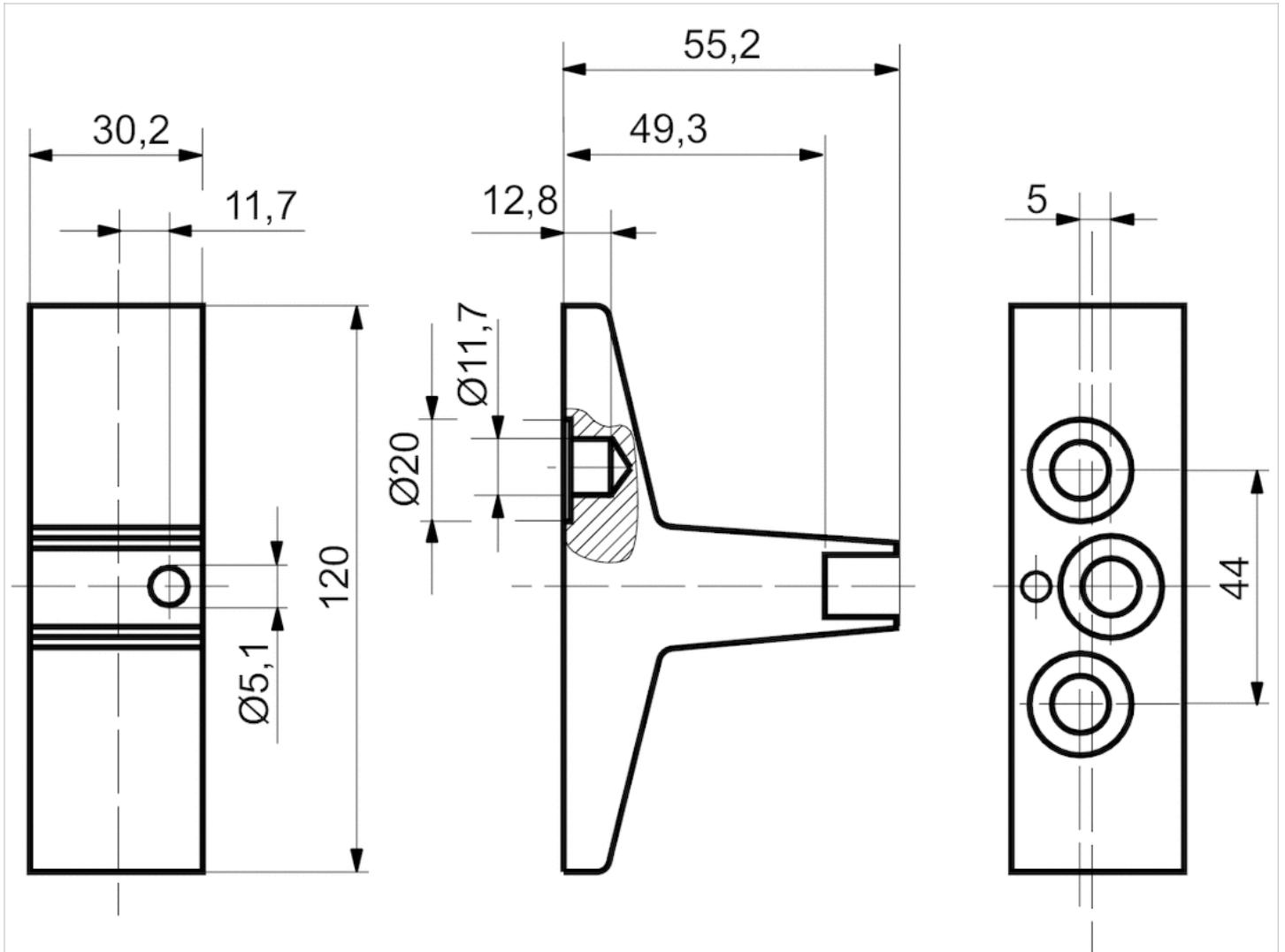

P-manifold

- for CD07

- 5/2 and 5/3-directional valves



Compressed air connection	according to ISO 228-1
Working pressure min./max.	-0.95 ... 16 bar
Ambient temperature min./max.	-25 ... 80 °C
Medium temperature min./max.	-25 ... 80 °C
Medium	Compressed air
Exhaust (3,5)	uncollected exhaust
Weight	See table below

Technical data

Part No.	Compressed air connection Input [1]	Number of valve positions	Weight
3337120222	Ø 10x1	2	0.277 kg
3337120232	Ø 10x1	3	0.338 kg
3337120242	Ø 10x1	4	0.401 kg
3337120252	Ø 10x1	5	0.462 kg
3337120262	Ø 10x1	6	0.52 kg
3337120272	Ø 10x1	7	0.595 kg
3337120282	Ø 10x1	8	0.64 kg
3337120292	Ø 10x1	9	0.705 kg
3337120302	Ø 10x1	10	0.773 kg
3337120312	Ø 10x1	11	0.82 kg
3337120322	Ø 10x1	12	0.914 kg

Technical information

The min. control pressure must be adhered to, since otherwise faulty switching and valve failure may result!

The pressure dew point must be at least 15 °C under ambient and medium temperature and may not exceed 3 °C .

The oil content of compressed air must remain constant during the life cycle.

Use only the approved oils from AVENTICS. Further information can be found in the "Technical information" document (available in the MediaCentre).

Technical information

Material	
Base plate	Aluminum Polyoxymethylene
Seal	Acrylonitrile butadiene rubber
Mounting bracket	Steel

Dimensions

Dimensions

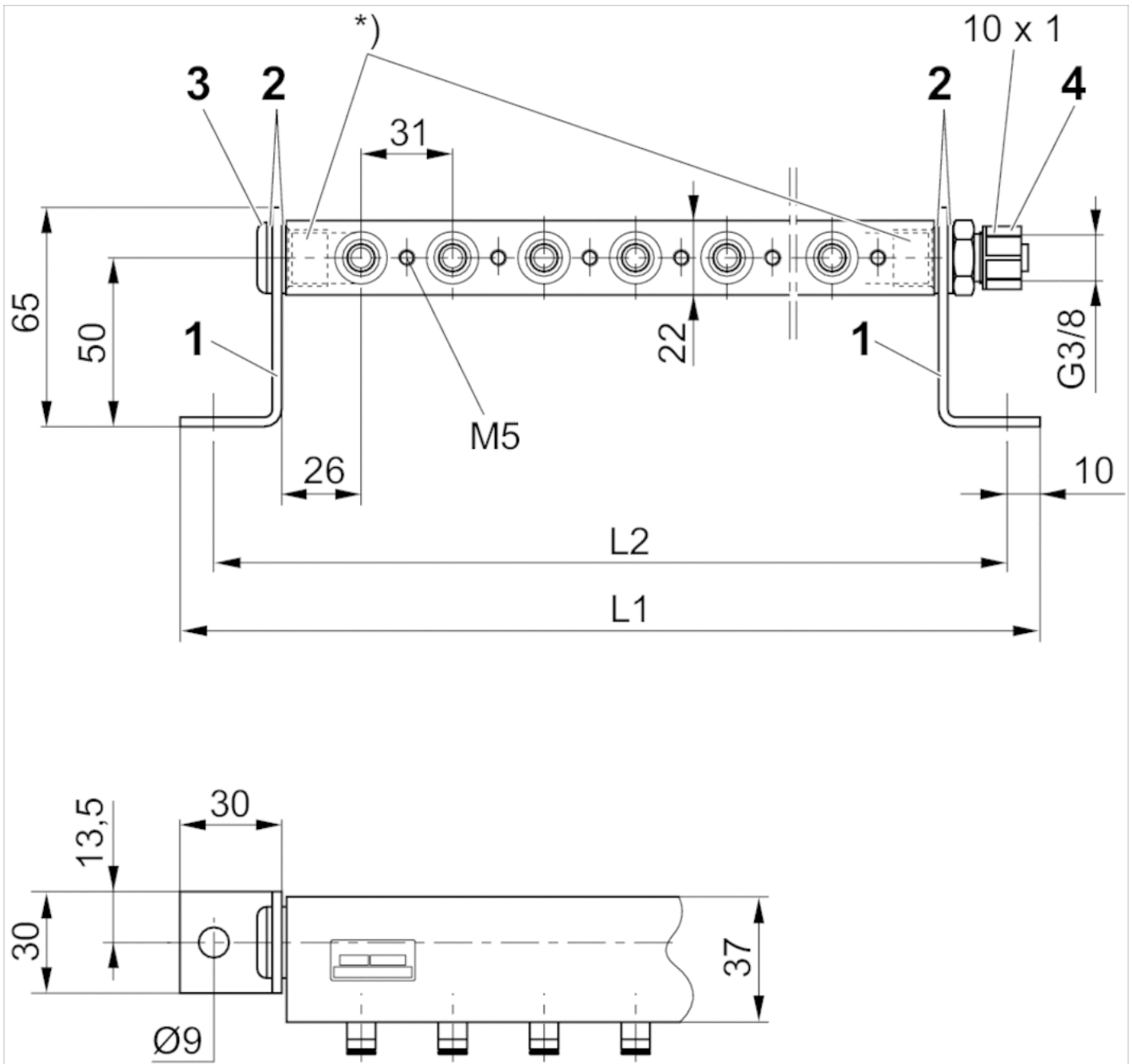

Angled bracket (1), seal DIN 7603 AI (2), blanking screw G 3/8 ISO 228/1 (3), push-in fittings G 3/8 ISO 228/1, diameter 10x1 (4)

* Only use fittings with max. length of thread engagement equal to 12 mm.

Valve mounting screws (depending on the valve used): washer, screw, O-ring must be ordered separately.

Dimensions

Part No.	L1	L2
3337120222	152	132
3337120232	183	163
3337120242	214	194
3337120252	245	225

Part No.	L1	L2
3337120262	276	256
3337120272	307	287
3337120282	338	318
3337120292	369	349
3337120302	400	380
3337120312	431	411
3337120322	462	442

R, P, S subbase, Series CD07



Compressed air connection	according to ISO 228-1
Working pressure min./max.	-0.95 ... 16 bar
Ambient temperature min./max.	-25 ... 80 °C
Medium temperature min./max.	-25 ... 80 °C
Medium	Compressed air
Exhaust (3,5)	With directional exhaust (3/5)
Exhaust type	Ports separated
Weight	See table below

Technical data

Part No.	Compressed air connection Input [1]	Compressed air connection Exhaust [3 / 5]
8985072042	G 1/2	G 1/2
8985072062	G 1/2	G 1/2
8985072082	G 1/2	G 1/2
8985072102	G 1/2	G 1/2
8985072122	G 1/2	G 1/2

Part No.	Compressed air connection Pilot connection [X]	Number of valve positions	Weight
8985072042	G 1/8	4	1.45 kg
8985072062	G 1/8	6	1.94 kg
8985072082	G 1/8	8	2.42 kg
8985072102	G 1/8	10	2.94 kg
8985072122	G 1/8	12	3.4 kg

Technical information

The min. control pressure must be adhered to, since otherwise faulty switching and valve failure may result!

The pressure dew point must be at least 15 °C under ambient and medium temperature and may not exceed 3 °C .

The oil content of compressed air must remain constant during the life cycle.

Use only the approved oils from AVENTICS. Further information can be found in the "Technical information" document (available in the MediaCentre).

Technical information

Material	
Base plate	Aluminum Polyoxymethylene
Seal	Acrylonitrile butadiene rubber

Dimensions

Dimensions

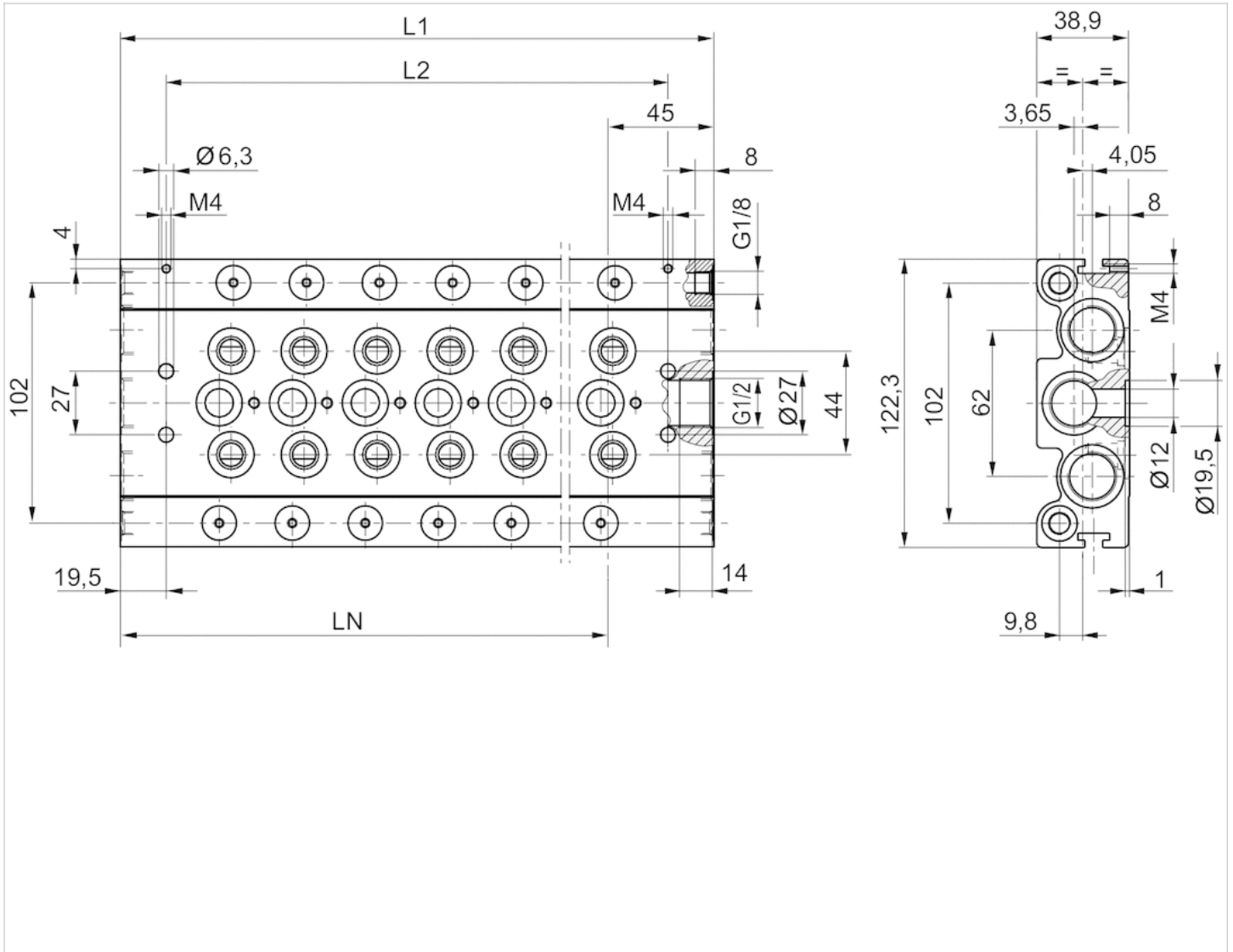

Dimensions

Part No.	L1	L2	LN
8985072042	183	144	138
8985072062	245	206	200
8985072082	307	268	262
8985072102	369	330	324
8985072122	431	392	386

Accessories, Series CD07



Weight

See table below

Technical data

Part No.	Fig.	Type
335460002	Fig. 1	Mounting kit for 10 valves, delivery includes: 30 seals, 10 washers, and 10 mounting screws.
8970810404	Fig. 4	Seal for external pilot
3354600082	Fig. 2	P plug
3354600072	Fig. 3	R/S plug

Part No.	Suitable for	Delivery unit	Weight
3354600002	R, P, S subbase	1 piece	0.125 kg
8970810404	R, P, S subbase	1 piece	0.001 kg
3354600082	R, P, S subbase	1 piece	0.022 kg
3354600072	R, P, S subbase	1 piece	0.023 kg

Dimensions

Fig.1

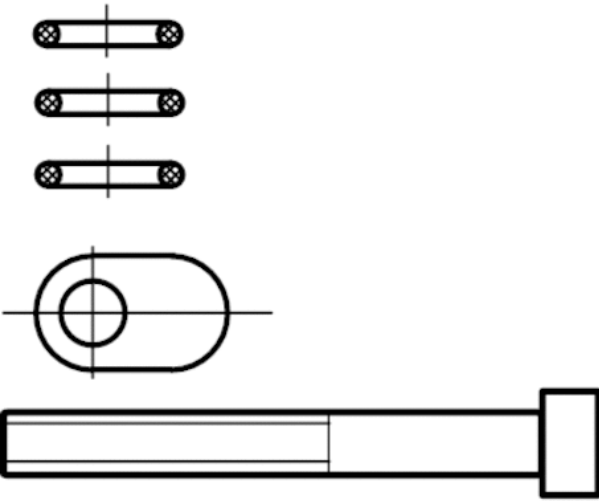

Fig.2

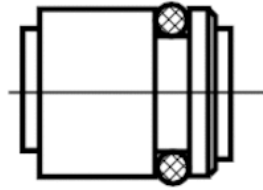
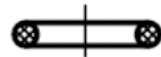

Fig.3



Fig.4



Kit, Series CD07

- for manual override



Weight

0.004 kg

Technical data

Part No.	Suitable for	Delivery unit
5420900002	Manual override lock	1 piece

Dimensions

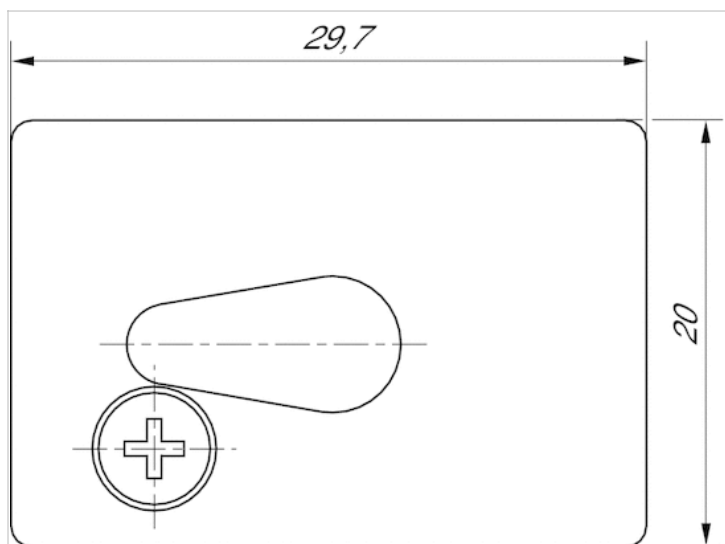

Accessories, Series CD07



Technical data

Part No.	Type	Delivery unit
5631174514	Protective cover	1 piece

Dimensions

Dimensions

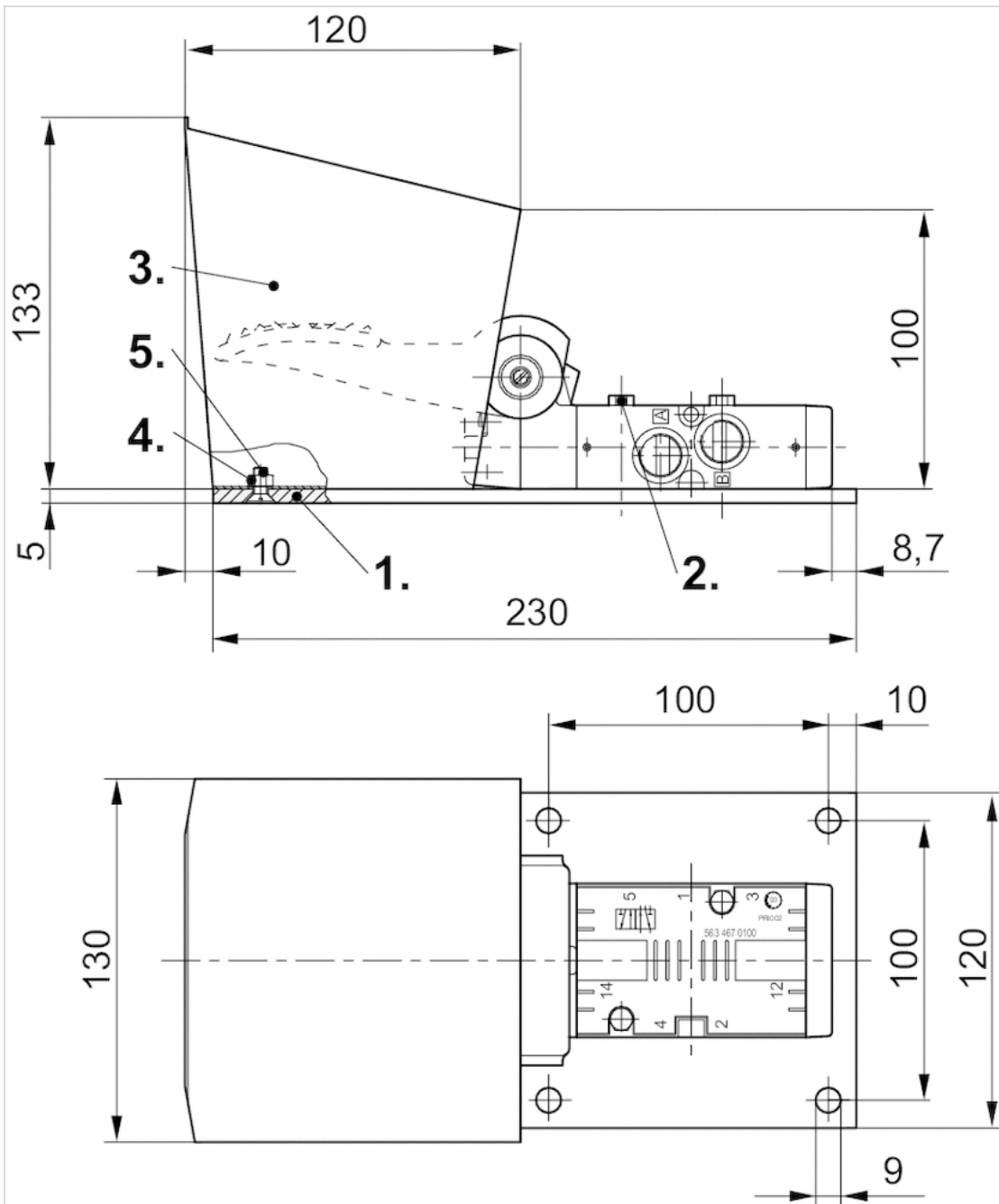

- 1) Mounting plate
- 2) Hexagon screw M5x35
- 3) Protective cover
- 4) Screw M5x12 (not included in scope of delivery)
- 5) Hexagonal nut M5 (not included in the delivery contents)

Accessories, Series CD07



Technical data

Part No.	Type	Delivery unit
5631171004	Mounting plate	1 piece
8101260304	Hexagon screw M5x35	1 piece

Mounting plate, Hexagon screw M5x35

Dimensions

Dimensions

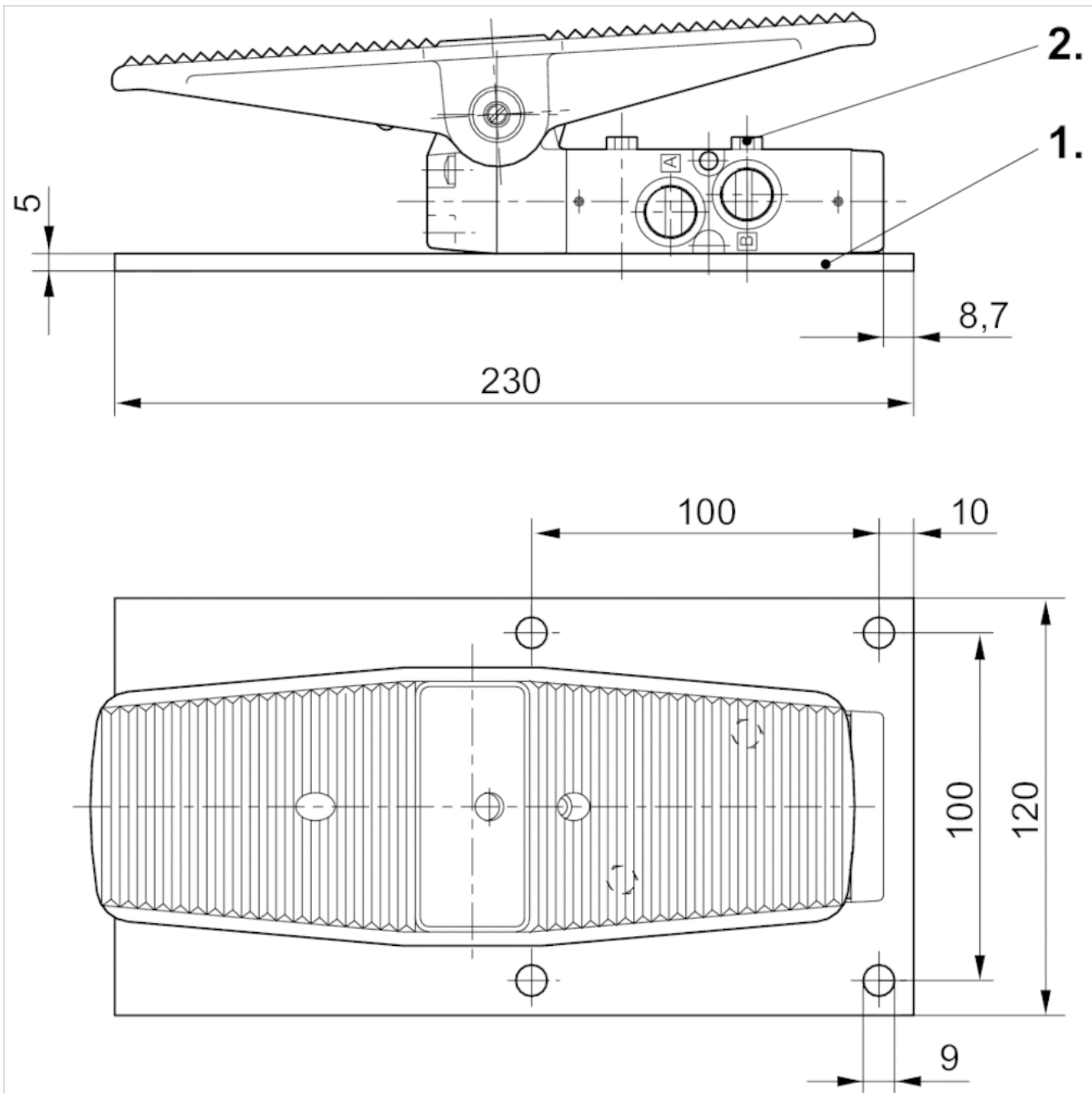

- 1) Mounting plate
- 2) Hexagon screw M5x35

Efficient pneumatic solutions, our program: cylinders and drives, valves and valve systems, air supply management



Visit us: [Emerson.com/Aventics](https://www.emerson.com/aventics)

Your local contact: [Emerson.com/contactus](https://www.emerson.com/contactus)



Emerson.com



[Facebook.com/EmersonAutomationSolutions](https://www.facebook.com/EmersonAutomationSolutions)



[LinkedIn.com/company/Emerson-Automation-Solutions](https://www.linkedin.com/company/Emerson-Automation-Solutions)



[Twitter.com/EMR_Automation](https://twitter.com/EMR_Automation)

An example configuration is depicted on the title page. The delivered product may thus vary from that in the illustration. Subject to change. This Document, as well as the data, specifications and other information set forth in it, are the exclusive property of AVENTICS GmbH. It may not be reproduced or given to third parties without its consent. Only use the AVENTICS products shown in industrial applications. Read the product documentation completely and carefully before using the product. Observe the applicable regulations and laws of the respective country. When integrating the product into applications, note the system manufacturer's specifications for safe use of the product. The data specified only serve to describe the product. No statements concerning a certain condition or suitability for a certain application can be derived from our information. The information given does not release the user from the obligation of own judgment and verification. It must be remembered that the products are subject to a natural process of wear and aging.

The Emerson logo is a trademark and service mark of Emerson Electric Co. Brand logotype are registered trademarks of one of the Emerson family of companies. All other marks are the property of their respective owners. © 2017 Emerson Electric Co. All rights reserved.
2019-03



CONSIDER IT SOLVED™